



Haltech Dual Channel Wideband Installation Instructions

Thank you for your recent purchase of the Haltech Dual Channel Wideband(HDCW). The HDCW is a dual channel wideband air/fuel ratio (AFR) metering system. The system has Two 0-5v analog AFR outputs. The Haltech DCW utilizes a Bosch 5-wire wide-band o2 sensor, and features a compact design, easy installation, and easy integration into your Haltech ECU.

INSTALLATION

1. Turn off the ignition and disconnect the battery ground cable.
2. The O2 sensor(s) should be located on the header/exhaust pipe about 6-8 inches from the head flange or 12-16 inches from the Turbine outlet. Ideally, the sensor tip should face down to avoid accumulation of condensation. When choosing a mounting location, allow several inches clearance for the sensor wire harness. The wire harness must exit straight out from the sensor. Do not loop the harness back onto the sensor body.
3. 18 x 1.5mm weld nuts must be welded onto the exhaust pipe. After welding, run an 18 x 1.5mm tap through the threads. Failure to clean the threads may result in sensor damage. **DO NOT INSTALL THE SENSORS UNTIL AFTER THE FREE AIR CALIBRATION.** This procedure will be covered in the next section. Always use an anti seize lubricant on the sensor threads.
4. From the HDCW connect the Thick Gauge BLACK WIRE to a Chassis GROUND. **DO NOT** extend the ground wire, **DO NOT** ground to your engine, and **DO NOT** ground to your battery minus terminal
Connect the Thin gauge BLACK Wire to the ECU Signal Ground wire .
Connect the RED wire to A SWITCHED +12v SOURCE.
Connect Sensor 1 Cable (Identified by a YELLOW band) to your wideband o2 sensor
Reconnect the battery ground cable

INTEGRATION

5. For Sensor 1: Connect the White 0-5v output wire from the HDCW into a Spare AVI Input of your Platinum Sport ECU
Sensor 2 : Connect the Blue 0-5v output wire into a separate Spare AVI Input
6. Connect Your Haltech Platinum Sport ECU to your laptop and go online with the ECU Manager Software.
Go to Software -> Main Setup -> Inputs. Set the corresponding AVI Inputs used to "O2 Wideband Sensor"

FREE AIR CALIBRATION

7. After installation, a free air calibration is required, preferably with the car outdoors. Turn the free air calibration trimpots on the HDCW full counterclockwise. Turn on power and wait for 60 seconds so the system can fully stabilize. Slowly turn each free air calibration trimpot clockwise until the corresponding LED starts flashing at a rapid rate. Try to set each trimpot at the point where its LED just starts to flash. Free air calibration should be performed every 300-800 km's for unleaded petrol and every 2-5 hours for leaded petrol. If you cannot get an LED to flash when its trimpot is turned full clockwise, you either have a damaged sensor or very high hydrocarbon levels in your environment. A fault indication will cause the status LED to blink at a slow rate. Fault conditions include less than 11 volts or greater than 16.5 volts of battery voltage, sensor open circuit, and sensor short circuit conditions.

GAUGE INSTALLATION

8. Connect the Gauge's BLACK wire to the ECU's Signal Ground Wire.
Connect the Gauge's RED wire to a switched +12v Power Source
Connect the Gauge's PURPLE wire to the headlight switch to dim the LEDs 50% when the headlights are on.
Connect the Gauge's BLUE wire to the 0-5v Signal Output'(Sensor 1 = white; Sensor 2=blue) on the HDCW
9. Enjoy the Benefits of Tuning with a Haltech Dual Channel Wideband and Tune with Confidence!



Haltech Dual Channel Wideband Wiring Diagram

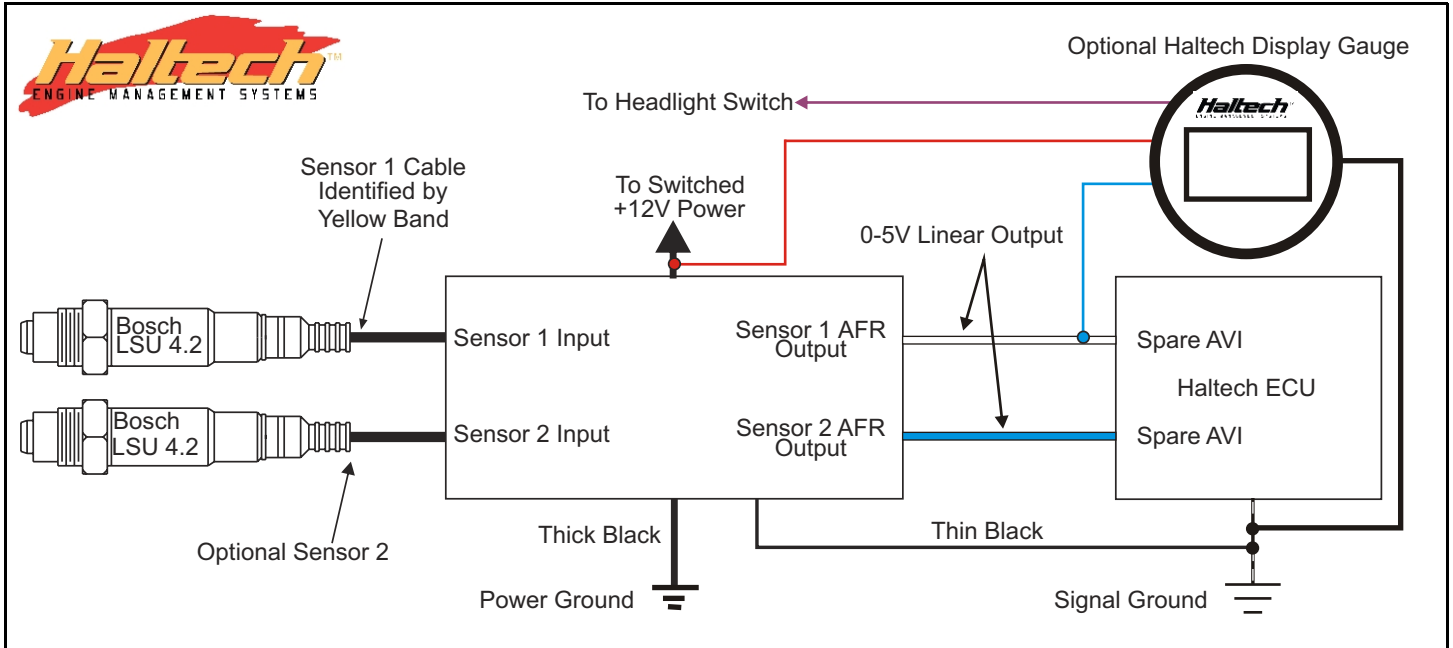

Wiring diagram with Haltech Gauge