

GROUP 26

FRONT AXLE

CONTENTS

GENERAL DESCRIPTION	26-2	DRIVE SHAFT ASSEMBLY	26-14
FRONT AXLE DIAGNOSIS	26-3	REMOVAL AND INSTALLATION	26-14
TROUBLESHOOTING STRATEGY	26-3	DISASSEMBLY AND ASSEMBLY	
SYMPTOM CHART.....	26-3	<2.4L ENGINE>.....	26-18
SYMPTOM PROCEDURES	26-4	DISASSEMBLY AND ASSEMBLY	
SPECIAL TOOLS	26-5	<3.8L ENGINE>.....	26-22
ON-VEHICLE SERVICE	26-8	INSPECTION.....	26-29
WHEEL BEARING END PLAY CHECK ...	26-8	BJ/EBJ BOOT REPLACEMENT	26-30
HUB BOLT REPLACEMENT	26-8	SPECIFICATIONS	26-33
FRONT AXLE HUB ASSEMBLY	26-9	FASTENER TIGHTENING	
REMOVAL AND INSTALLATION.....	26-9	SPECIFICATIONS.....	26-33
INSPECTION	26-12	GENERAL SPECIFICATIONS	26-33
		SERVICE SPECIFICATIONS	26-33
		LUBRICANTS	26-34

GENERAL DESCRIPTION

M1261000100563

The front axle consists of front hub unit bearings, knuckles and drive shafts, and it has the following features:

- The wheel bearing incorporates a unit ball bearing (double-row angular contact ball bearing) for reduced friction.
- The front wheel hub assembly combines the hub, wheel bearing, and oil seal in a single unit for fewer parts, better durability, improved assembly precision, and better structural organization.
- The drive shaft incorporates BJ-TJ type constant velocity joints <2.4L engine> and EBJ-PTJ type constant velocity joints <3.8L engine> with high transaxle efficiency for low vibration and noise.

- Due to the use of the inner shaft and bracket assembly, the right and left drive shafts are approximately the same in length. This reduces noise, vibration and torque steer. <3.8L engine-RH>
- The dynamic damper is mounted on the LH drive shaft <all models> and on the RH drive shaft <2.4L engine> to reduce differential gear noise.
- ABS rotor for detecting the wheel speed is press-fitted to the BJ <2.4L engine> and EBJ <3.8L engine>.

BJ: Birfield Joint

TJ: Tripod joint

EBJ (Eight Ball Fixed Joint): The use of the smaller size eight balls inside the joint achieves weight saving and compact size compared with BJ.

PTJ: Pillow Tripod Joint

CONSTRUCTION DIAGRAM

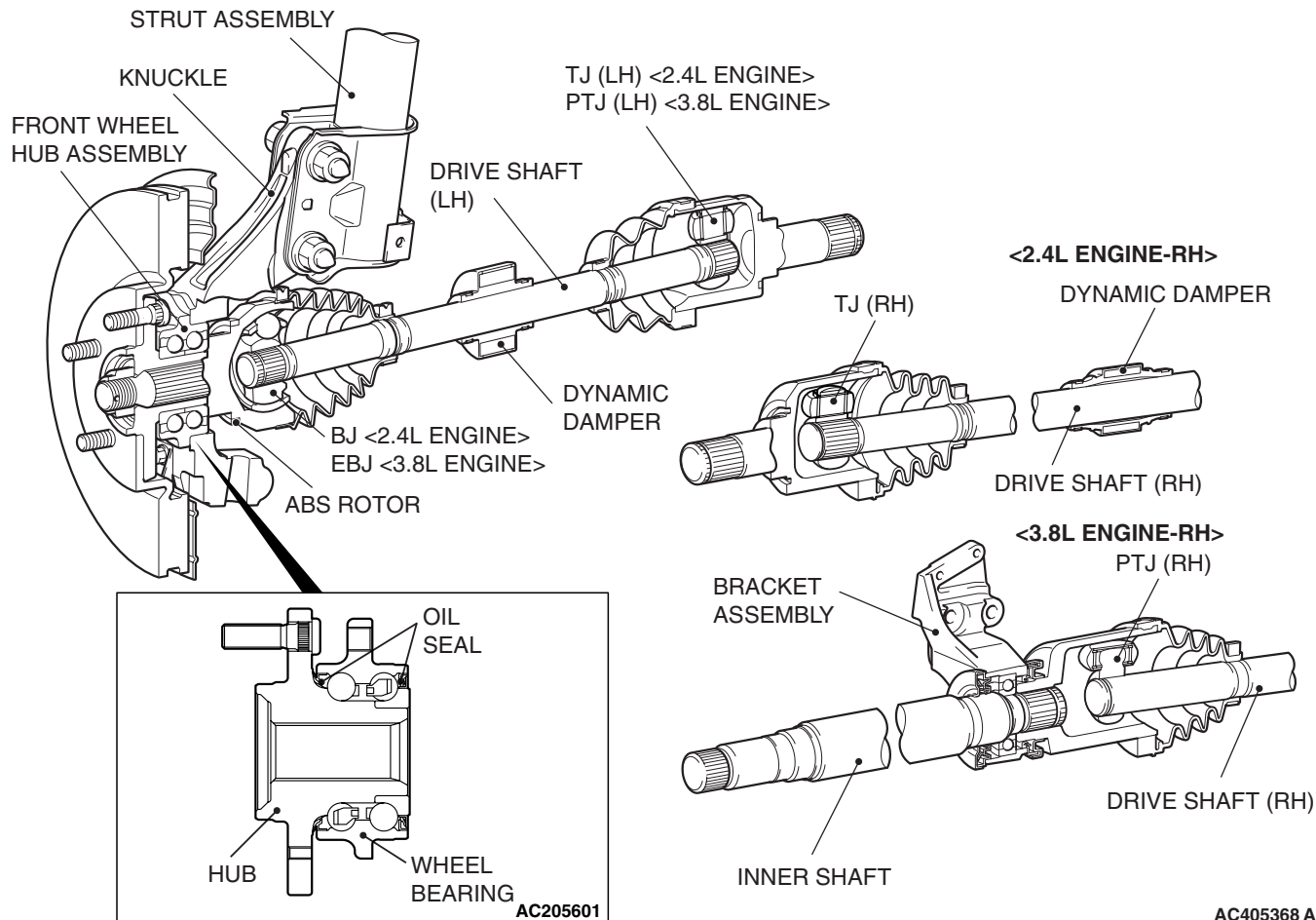

FRONT AXLE DIAGNOSIS

TROUBLESHOOTING STRATEGY

Use these steps to plan your diagnostic strategy. If you follow them carefully, you will be sure that you have exhausted most of the possible ways to find a front axle fault.

1. Gather information from the customer.

- M1261005600240
2. Verify that the condition described by the customer exists.
 3. Find the malfunction by following the Symptom Chart.
 4. Verify malfunction is eliminated.

SYMPTOM CHART

M1261005700269

SYMPTOM		INSPECTION PROCEDURE	REFERENCE PAGE
Drive shaft	Noise during wheel rotation	1	P.26-4
	Noise due to excessive play of wheel in turning direction	2	P.26-5

SYMPTOM PROCEDURES

INSPECTION PROCEDURE 1: Noise during Wheel Rotation

DIAGNOSIS

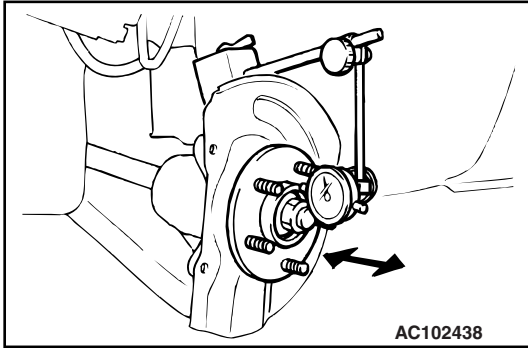
**STEP 1. Check the wheel bearing end play.**

- (1) Remove the caliper assembly and suspend it with a wire.
- (2) Remove the brake disc from the front hub.
- (3) Attach a dial gauge as shown in the illustration, and then measure the end play while moving the hub in the axial direction.

Limit: 0.05 mm (0.002 inch)

Q: Is the wheel bearing end play within the limit?

YES : Go to step 2.

NO : Replace the part, then go to Step 5.

STEP 2. Check the drive shaft and inner shaft for bending.**Q: Is the drive shaft and inner shaft bent?**

YES : Replace the part. Then go to Step 5.

NO : Go to step 3.

STEP 3. Check the center bearing for wear.**Q: Is the center bearing worn?**

YES : Replace the bearing. Then go to Step 5.

NO : Go to step 4.

STEP 4. Check the drive shaft assembly for wear or damage.**Q: Is the drive shaft assembly worn or damaged?**

YES : Replace the drive shaft assembly. Then go to Step 5.

NO : There is no action to be taken.

STEP 5. Retest the system.**Q: Is the abnormal noise eliminated?**

YES : The procedure is complete.

NO : Repeat from Step 1.

INSPECTION PROCEDURE 2: Noise Due to Excessive Play of Wheel in Turning Direction

DIAGNOSIS

STEP 1. Check for play in the inner shaft and side gear serration, the drive shaft and side gear serration, or the drive shaft and front hub serration.

Q: Is the play found?

- YES :** Replace the part. Then go to Step 2.
- NO :** The procedure is complete.



STEP 2. Retest the system.



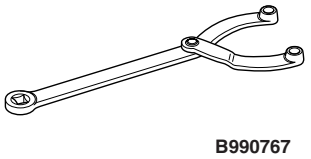
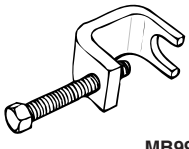
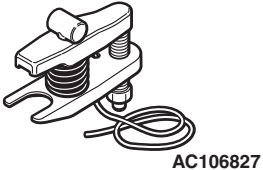
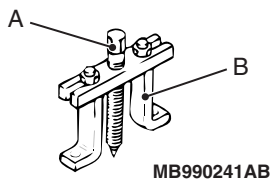

Q: Is the abnormal noise eliminated?

- YES :** The procedure is complete.
- NO :** Repeat from Step 1.

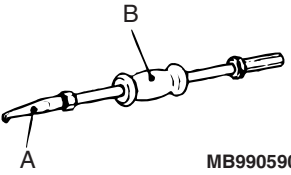
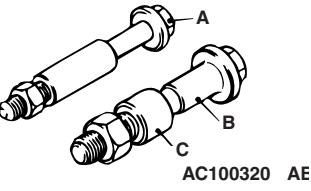

SPECIAL TOOLS

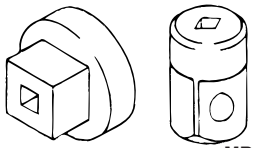
M1261000600643

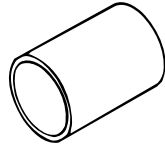
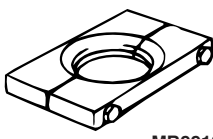
TOOL	TOOL NUMBER AND NAME	SUPERSESSION	APPLICATION
	MB990767 Front hub and flange yoke holder	MB990767-01	Fixing of the hub
	MB991618 Hub bolt remover	General service tool	Removal of the hub bolt
	MB991897 Ball joint remover	MB991113-01, MB990635-01 or General service tool	Knuckle and tie rod end ball joint disconnection <i>NOTE: Steering linkage puller (MB990635 or MB991113) is also used to disconnect knuckle and tie rod end ball joint.</i>
	MB990241 Axle shaft puller A: MB990242 Puller shaft B: MB990244 Puller bar	MB990241-01 or General service tool	Removal of the drive shaft
	MB991354 Puller body	General service tool	

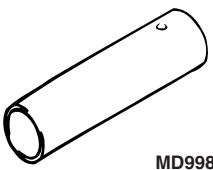
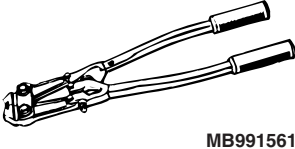
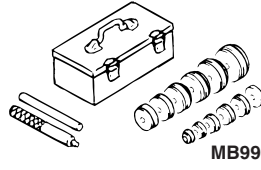
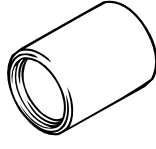
TOOL	TOOL NUMBER AND NAME	SUPERSESION	APPLICATION
 <p>MB990590</p>	MB990590 Rear axle shaft oil seal remover A: MB990212 Adapter B: MB990211 Slide hammer	MB990211-01	Removal of the front wheel hub
 <p>AC100320 AE</p>	A: MB991017 B: MB990998 C: MB991000 A, B: Front hub remover and installer C: Spacer	MB990998-01	<ul style="list-style-type: none"> Removal of the hub Provisional holding of the wheel bearing Measurement of hub starting torque Measurement of wheel bearing end play <p><i>NOTE: MB991000, which belongs to MB990998, should be used as a spacer.</i></p>
	MB990685 Torque wrench	General service tool	Measurement of hub starting torque
 <p>MB990326</p>	MB990326 Preload socket	General service tool	
 <p>MB990810</p>	MB990810 Side bearing puller	General service tool	<ul style="list-style-type: none"> Removal of the center bearing bracket Removal of the wheel bearing inner race (outside)
	MB991172 Inner shaft installer base	-	Press-fitting of the inner shaft
 <p>MB991248</p>	MB991248 Inner shaft remover	MD998348-01 or General service tool	Removal of the inner shaft

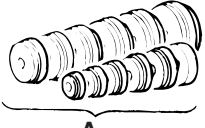
TOOL	TOOL NUMBER AND NAME	SUPERSESION	APPLICATION
 MD998369	MD998369 Bearing installer	–	Installation of the seal plate
 MB991561	MB991561 Boot band crimping tool	MB991561	BJ boot (resin boot) band installation
 MB990925	MB990925 Bearing and oil seal installer set	MB990925-01 or General service tool	<ul style="list-style-type: none"> Removal and installation of the center bearing Press-fitting of the dust seal outer, inner
 MB990890	MB990890 Rear suspension bushing base	MB990890-01	Press-fitting of the dust seal outer, inner

TOOL	TYPE	TOOL NUMBER	O D mm (in)
 <p>A INSTALLER ADAPTER</p> <p>C BRASS BAR</p> <p>B BAR (SNAP-IN TYPE)</p>  <p>TOOL BOX ACX02372 AC</p>	A	MB990926	39.0 (1.54)
		MB990927	45.0 (1.77)
		MB990928	49.5 (1.95)
		MB990929	51.0 (2.00)
		MB990930	54.0 (2.13)
		MB990931	57.0 (2.24)
		MB990932	61.0 (2.40)
		MB990933	63.5 (2.50)
		MB990934	67.5 (2.66)
		MB990935	71.5 (2.81)
	MB990936	75.5 (2.97)	
	MB990937	79.0 (3.11)	
		B	MB990938
	C	MB990939	–

ON-VEHICLE SERVICE**WHEEL BEARING END PLAY CHECK**

M1261000900246

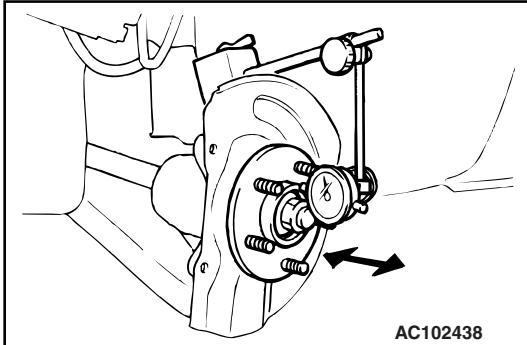

1. Remove the caliper assembly and suspend it with a wire.
2. Remove the brake disc from the front hub.
3. Attach a dial gauge as shown in the illustration, and then measure the end play while moving the hub in the axial direction.

Limit: 0.05 mm (0.002 inch)

4. If end play exceeds the limit, disassemble the front hub assembly and check the parts.
5. Install the brake disc, caliper assembly and tighten the caliper assembly mounting bolts to the specified torque.

Tightening torque: 100 ± 10 N·m (74 ± 7 ft-lb)

HUB BOLT REPLACEMENT

M1261001000310

Required Special Tools:

- MB990767: Front Hub and Flange Yoke Holder
- MB991618: Hub Bolt Remover

1. Remove the caliper assembly and suspend it with wire so that it does not fall.
2. Remove the brake disc.
3. Use special tool MB991618 to remove the hub bolts.

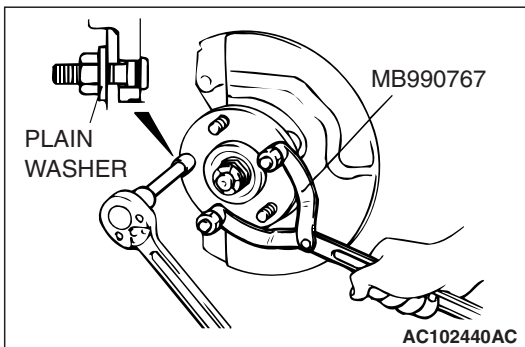
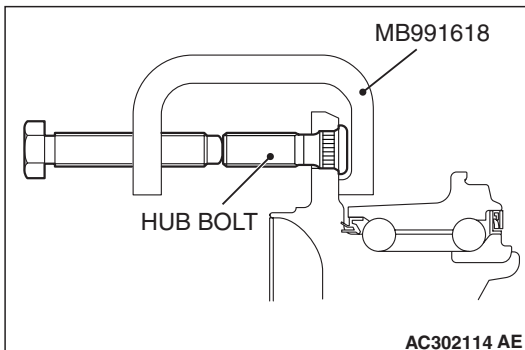

4. Install the plain washer to the new hub bolt, and install the bolt with a nut while holding the hub with special tool MB990767.
5. Install the brake disc, caliper assembly and tighten the caliper assembly mounting bolts to the specified torque.

Tightening torque: 100 ± 10 N·m (74 ± 7 ft-lb)

FRONT AXLE HUB ASSEMBLY

REMOVAL AND INSTALLATION

M1261001700610

CAUTION

- Do not strike the ABS rotors installed to the BJ or EBJ outer race of drive shaft against other parts when removing or installing the drive shaft. Otherwise the ABS rotors will be damaged.
- Be careful not to strike the pole piece at the tip of the front wheel speed sensor with tools during servicing work.

Post-installation Operation

Check the dust cover for cracks or damage by pushing it with your finger.

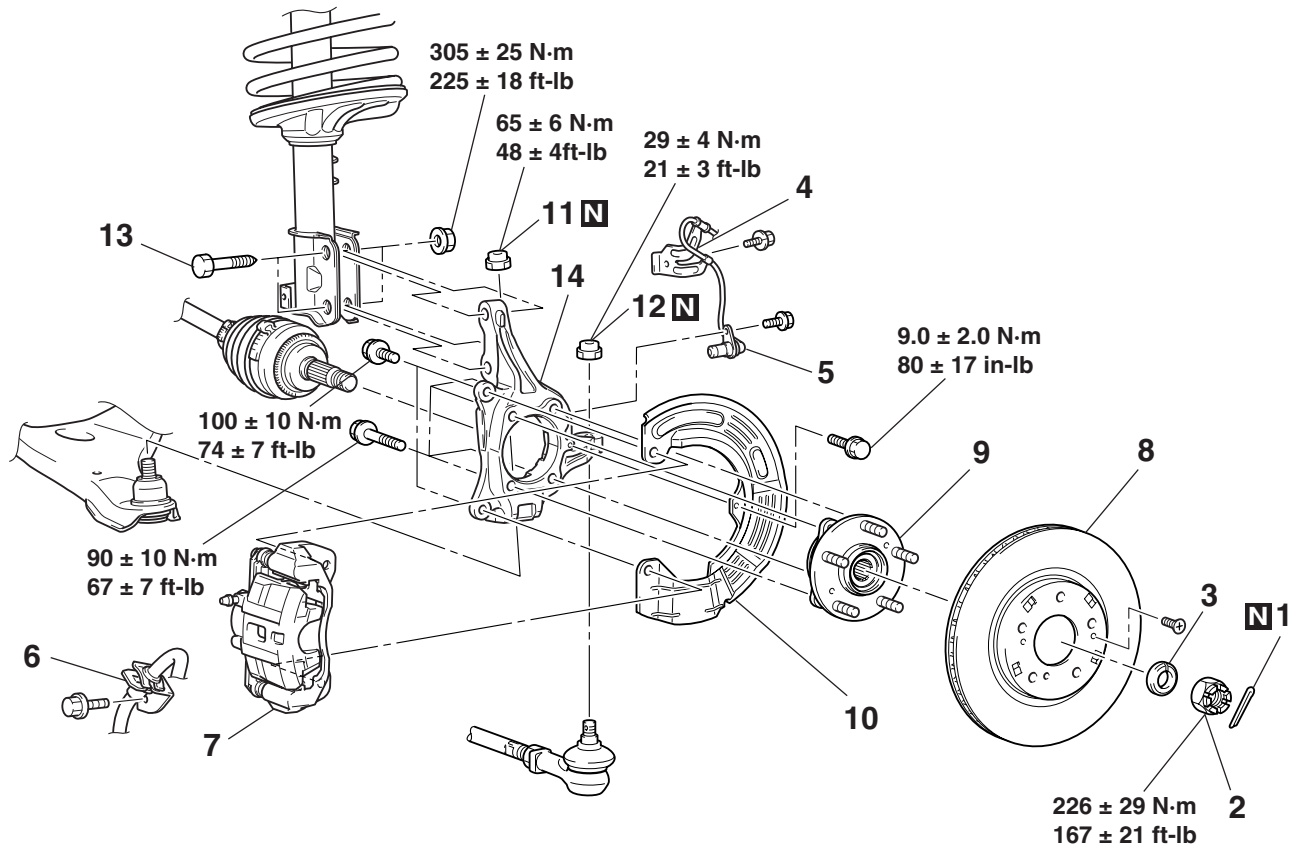

AC305336 AC

REMOVAL STEPS

- | | | |
|-------|--------------|-------------------------------------|
| | 1. SPLIT PIN | <<E>> |
| <<A>> | >>A<< | 2. DRIVE SHAFT NUT |
| | >>A<< | 3. WASHER |
| | | 4. FRONT WHEEL SPEED SENSOR BRACKET |
| | | 5. FRONT WHEEL SPEED SENSOR |
| <> | | 6. BRAKE HOSE BRACKET |
| <<C>> | | 7. CALIPER ASSEMBLY |
| | | 8. BRAKE DISC |

REMOVAL STEPS (Continued)

- | | |
|--|--|
| | 9. FRONT WHEEL HUB ASSEMBLY |
| | 10. DUST COVER |
| | 11. SELF LOCKING NUT (CONNECTION FOR LOWER ARM BALL JOINT) |
| | 12. SELF LOCKING NUT (CONNECTION FOR TIE ROD END) |
| | 13. FRONT STRUT TO KNUCKLE MOUNTING BOLT AND NUT |
| | 14. KNUCKLE |

Required Special Tools:

- MB990211: Slide Hammer
- MB990242: Puller Shaft
- MB990244: Puller Bar
- MB990767: Front Hub and Flange Yoke Holder
- MB991354: Puller Body
- MB991897: Ball Joint Remover

REMOVAL SERVICE POINTS**<<A>> DRIVE SHAFT NUT REMOVAL****⚠ CAUTION**

Do not apply pressure to wheel bearing by the vehicle weight to avoid possible damage when drive shaft nut is loosened.

Use special tool MB990767 to fix the hub and remove the drive shaft nut.

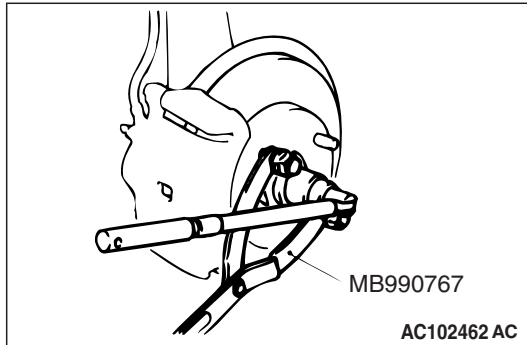
**<> CALIPER ASSEMBLY REMOVAL**

Secure the removed caliper assembly with wire, etc.

<<C>> BRAKE DISC REMOVAL

If the brake disc is seized, install a M8 x 1.25 bolts as shown, and remove the disc by tightening the bolts evenly and gradually.

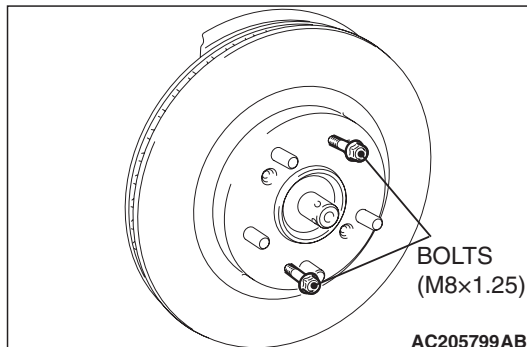

<<D>> SELF LOCKING NUT (CONNECTION FOR LOWER ARM BALL JOINT AND TIE ROD END) REMOVAL

⚠ CAUTION

- Do not remove the nut from ball joint. Loosen it and use the special tool to avoid possible damage to ball joint threads.
- Hang the special tool with cord to prevent it from falling.

1. Replace the self locking nut for lower arm ball joint with a regular nut, because the original one is a little bit large to install the special tool. Install special tool MB991897 as shown in the figure.

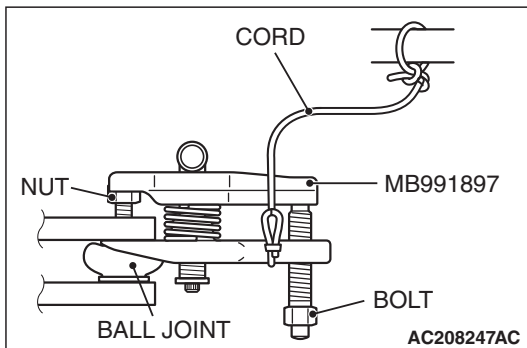

2. Turn the bolt and knob as necessary to make the jaws of special tool parallel, tighten the bolt by hand and confirm that the jaws are still parallel.

NOTE: When adjusting the jaws in parallel, make sure the knob is in the position shown in the figure.

3. Tighten the bolt with a wrench to disconnect the lower arm ball joint, tie rod end and remove the self locking nut.

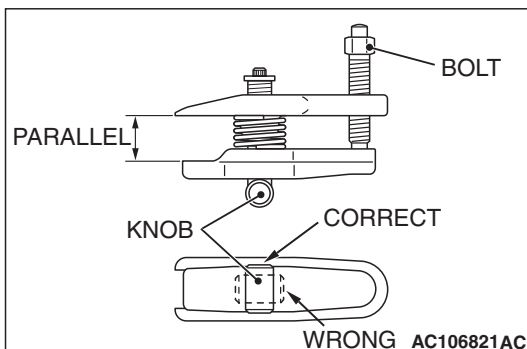

<<E>> FRONT WHEEL HUB ASSEMBLY REMOVAL

1. Remove the front wheel hub mounting bolts while pushing out the drive shaft by hand.
2. If it is difficult to push out the drive shaft by hand, use special tools MB990242, MB990244, MB991354 and MB990767 to push out the drive shaft from the hub and knuckle.
3. If the front wheel hub is seized, remove the knuckle together with front wheel hub and fix them with a vise.
4. Hang the drive shaft on the vehicle body with a rope.

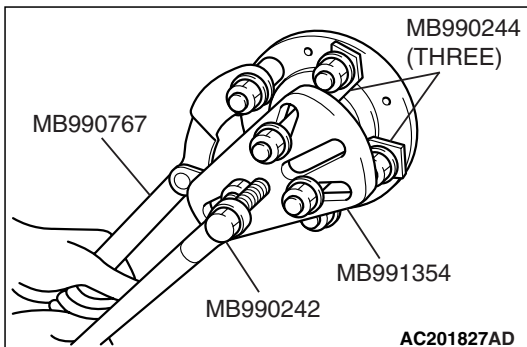

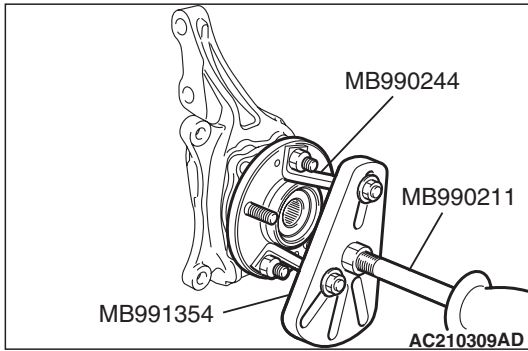

5. Use special tools MB990244, MB991354 and MB990211 to pull out the front wheel hub from the knuckle.

INSTALLATION SERVICE POINT

>>A<<WASHER/ DRIVE SHAFT NUT INSTALLATION

⚠ CAUTION

Before securely tightening the drive shaft nuts, make sure there is no load on the wheel bearings. Otherwise the wheel bearings will be damaged.

1. Be sure to install the drive shaft washer in the specified direction.
2. Using special tool MB990767, tighten the drive shaft nut to the specified torque.

Tightening torque: 226 ± 29 N· m (167 ± 21 ft-lb)

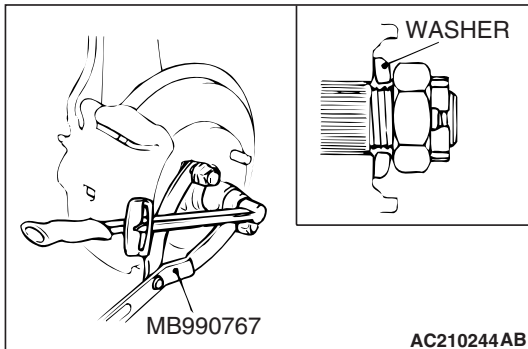

INSPECTION

M1261001800264

WHEEL BEARING ROTATION STARTING TORQUE AND AXIAL PLAY CHECK

Required Special Tools:

- MB990998: Front Hub Remover and Installer
- MB991000: Spacer
- MB990326: Preload Socket
- MB990685: Torque Wrench

1. Install special tools MB991000, MB990998 and tighten them to the specified torque.

Tightening torque: 226 ± 29 N· m (167 ± 21 ft-lb)

2. Hold front wheel hub assembly in a vice, using wooden blocks.
3. Rotate the hub in order to seat the bearing.

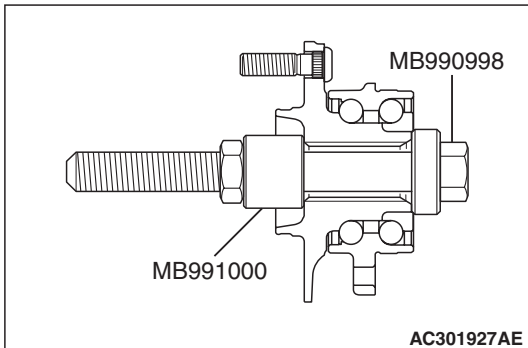

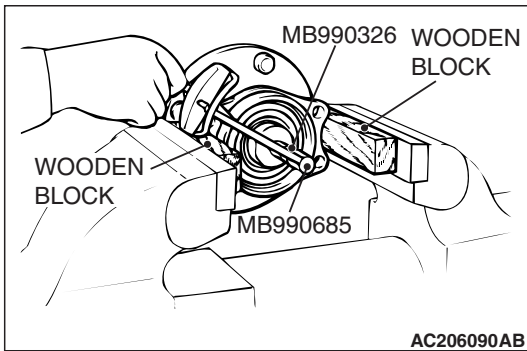

4. Measure the wheel bearing rotation starting torque by using the special tools MB990326 and MB990685.

Limit: 1.4 N·m (12 in-lb)

5. If the rotation starting torque is not within the limit when the nut is tightened to 226 ± 29 N·m (167 ± 21 ft-lb), replace the front wheel bearing assembly. If there is any signs of binding or tight spots when the wheel bearing turns, replace it.

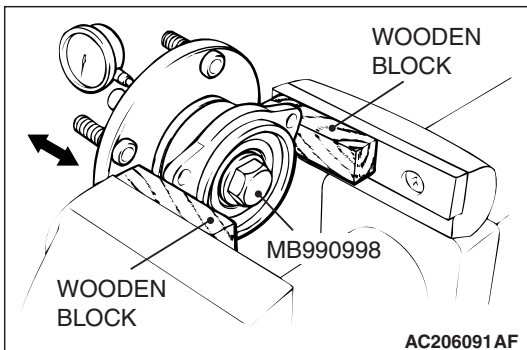

6. Measure to determine whether the wheel bearing axial play is within the specified limit or not.

Limit: 0.05 mm (0.002 inch)

7. If the play exceeds the limit when the nut is tightened to 226 ± 29 N·m (167 ± 21 ft-lb), replace the front wheel hub assembly.

DRIVE SHAFT ASSEMBLY

REMOVAL AND INSTALLATION

M1261003500753

CAUTION

- Do not strike the ABS rotors installed to the BJ or EBJ outer race of drive shaft against other parts when removing or installing the drive shaft. Otherwise the ABS rotors will be damaged.
- Be careful not to strike the pole piece at the tip of the front wheel speed sensor with tools during servicing work.

Pre-installation Operation	Post-installation Operation
<ul style="list-style-type: none"> • Front Under Cover, Side Under Cover Removal • Transmission Fluid Draining (Refer to GROUP 22A, On-vehicle Service –Transmission Oil Replacement P.22A-10, GROUP 23A, On-vehicle Service –Transmission Fluid Change P.23A-381). • Front Exhaust Pipe Removal <3.8L ENGINE-RH side> (Refer to GROUP 15, Exhaust Pipe and Muffler P.15-23). 	<ul style="list-style-type: none"> • Front Exhaust Pipe Installation <3.8L ENGINE-RH side> (Refer to GROUP 15, Exhaust Pipe and Muffler P.15-24). • Check the ball joint dust cover for cracks or damage by pushing it with your finger. • Transmission Fluid Draining (Refer to GROUP 22A, On-vehicle Service –Transmission Oil Replacement P.22A-10, GROUP 23A, On-vehicle Service –Transmission Fluid Change P.23A-381). • Front Under Cover, Side Under Cover Installation

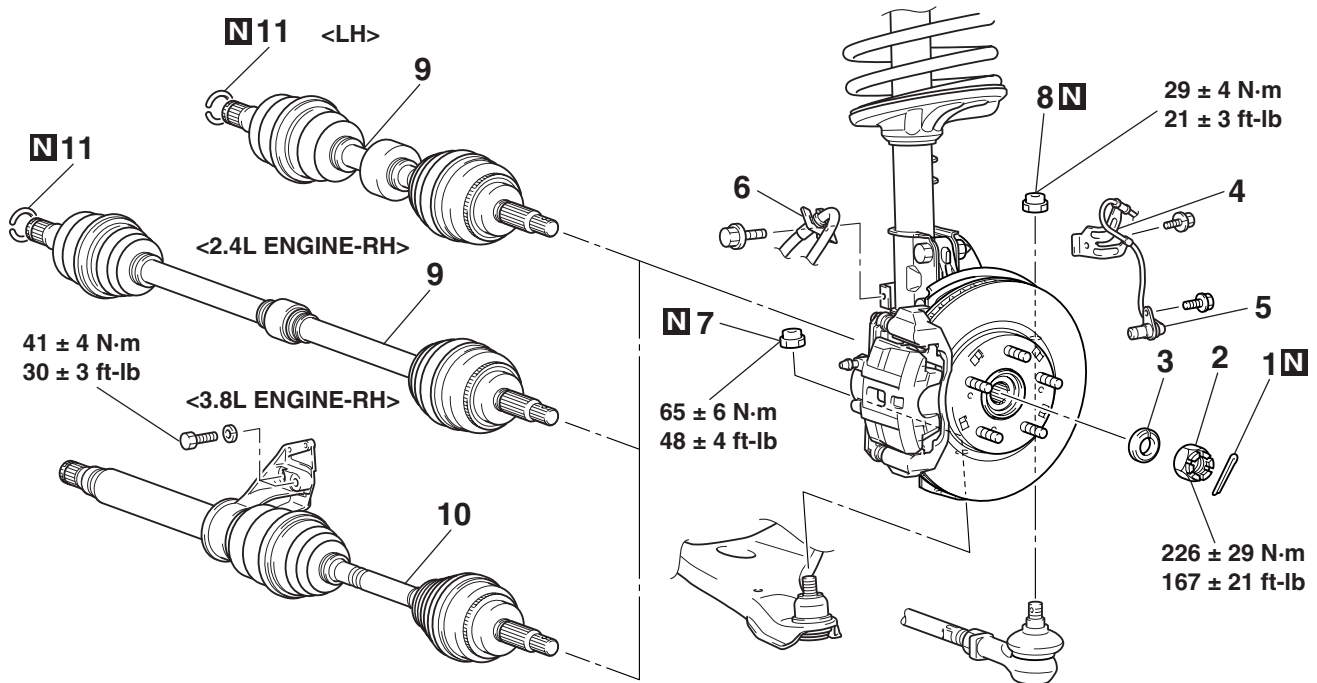

AC405390 AB

REMOVAL STEPS

- | | | | | | | | |
|-------|-------|----|--|-------|-------|---|--|
| <<A>> | >>B<< | 1. | SPLIT PIN | <> | 8. | SELF LOCKING NUT (TIE ROD END CONNECTION) | |
| | | 2. | DRIVE SHAFT NUT | <<C>> | >>A<< | 9. | DRIVE SHAFT |
| | | 3. | WASHER | <<C>> | >>A<< | 10. | DRIVE SHAFT AND INNER SHAFT ASSEMBLY<3.8L ENGINE-RH> |
| | | 4. | FRONT WHEEL SPEED SENSOR BRACKET | | | 11. | CIRCLIP |
| | | 5. | FRONT WHEEL SPEED SENSOR | | | | |
| | | 6. | BRAKE HOSE BRACKET | | | | |
| <> | | 7. | SELF LOCKING NUT (LOWER ARM BALL JOINT CONNECTION) | | | | |

Required Special Tools:

- MB990242: Puller Shaft Puller
- MB990244: Puller Bar
- MB990767: Front Hub and Flange Yoke Holder
- MB990998: Front Hub Remover and Installer
- MB991000: Spacer
- MB991354: Puller Body
- MB991897: Ball Joint Remover

REMOVAL SERVICE POINTS

<<A>> DRIVE SHAFT NUT REMOVAL

⚠ CAUTION

Do not apply pressure to the wheel bearing by the vehicle weight to avoid possible damage when the drive shaft nut is loosened.

Use special tool MB990767 to fix the hub and remove the drive shaft nut.

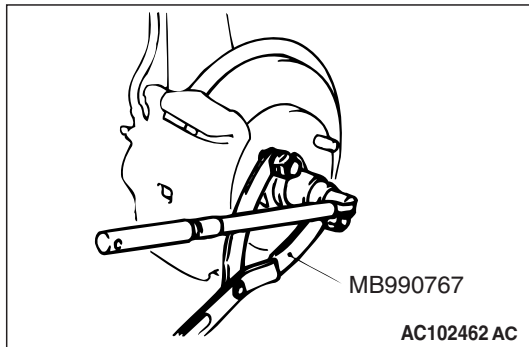

<>SELF LOCKING NUT (LOWER ARM BALL JOINT/TIE ROD END CONNECTION) REMOVAL

⚠ CAUTION

- Do not remove the nut from ball joint. Loosen it and use the special tool to avoid possible damage to ball joint threads.
- Hang the special tool with cord to prevent it from falling.

1. Replace the self locking nut with a regular nut, because the original one is too large to allow installation of the special tool. Install special tool MB991897 as shown in the figure.

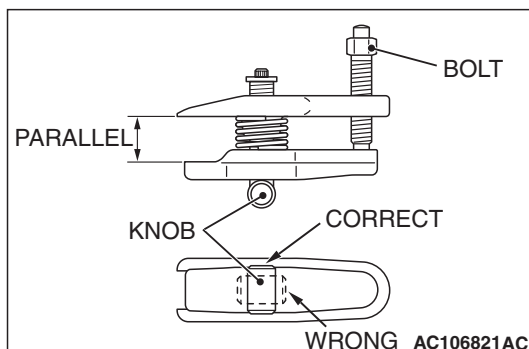
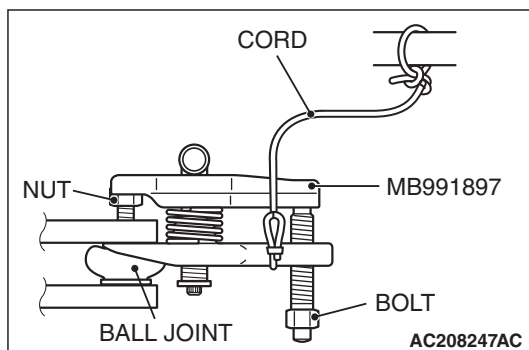

2. Turn the bolt and knob as necessary to make the jaws of special tool MB991897 parallel, tighten the bolt by hand and confirm that the jaws are still parallel.

NOTE: When adjusting the jaws in parallel, make sure the knob is in the position shown in the figure.

3. Tighten the bolt with a wrench to disconnect the tie rod end and remove the self locking nut.

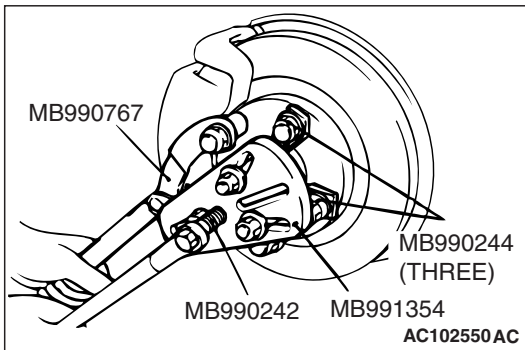
<<C>> DRIVE SHAFT/DRIVE SHAFT AND INNER
SHAFT ASSEMBLY <3.8L ENGINE- RH>
REMOVAL

1. Use special tools MB990242, MB990244, MB991354 and MB990767 to push out the drive shaft or the drive shaft and inner shaft assembly from the hub.

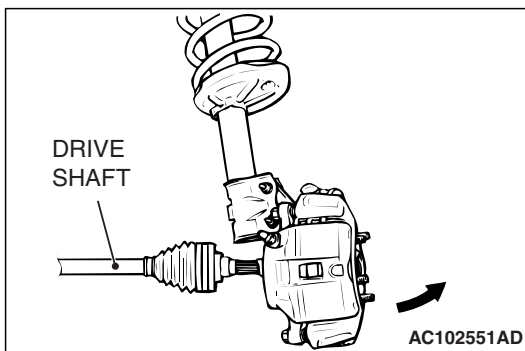

2. Remove the drive shaft from the hub by pulling the bottom of the brake disc towards you.

⚠ CAUTION

- Do not pull on the drive shaft; doing so will damage the TJ or PTJ; be sure to use the pry bar.
- When pulling the drive shaft out from the transaxle, be careful that the spline part of the drive shaft does not damage the oil seal.

3. Insert a pry bar between the transaxle case and the drive shaft, and then pry and remove the drive shaft from the transaxle.

NOTE: Insert a pry bar, taking care not to damage the protrusion of transaxle case when removing the drive shaft LH.

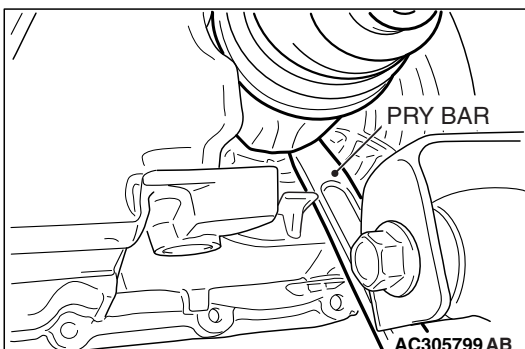
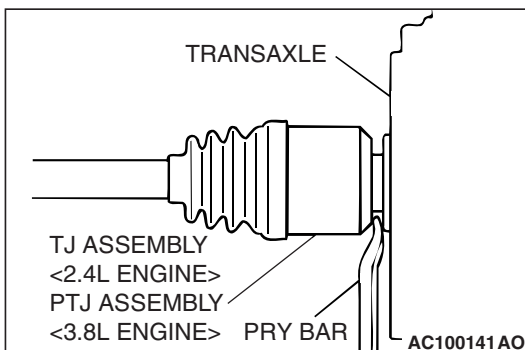

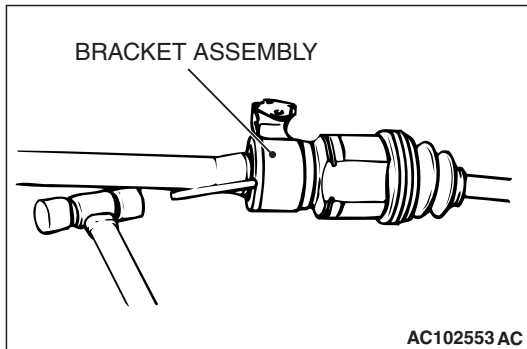

- If the inner shaft is hard to remove from the transaxle, strike the bracket assembly lightly with a plastic hammer and remove the inner shaft.

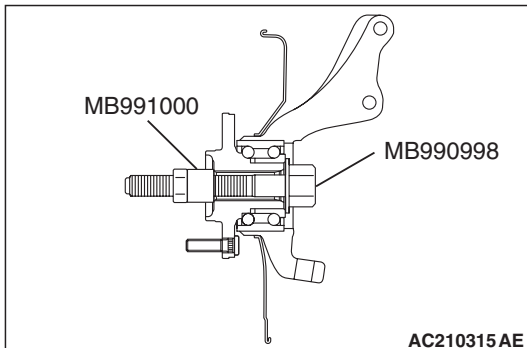

CAUTION

Do not apply pressure to the wheel bearing by the vehicle weight to avoid possible damage when the drive shaft is removed. If, however, vehicle weight must be applied to the bearing to move the vehicle, temporarily secure the wheel bearing by using special tools MB991000 and MB990998.

INSTALLATION SERVICE POINTS

>>A<< DRIVE SHAFT AND INNER SHAFT ASSEMBLY <3.8L ENGINE- RH>/DRIVE SHAFT INSTALLATION

CAUTION

When installing the drive shaft or the drive shaft and inner shaft assembly, be careful that the spline part of the drive shaft or the drive shaft and inner shaft assembly do not damage the oil seal.

>>B<< DRIVE SHAFT NUT INSTALLATION

- Be sure to install the drive shaft washer in the specified direction.

CAUTION

Before securely tightening the drive shaft nuts, make sure there is no load on the wheel bearings. Otherwise the wheel bearing will be damaged.

- Using special tool MB990767, tighten the drive shaft nut to the specified torque.

Tightening torque: 226 ± 29 N·m (167 ± 21 ft-lb)

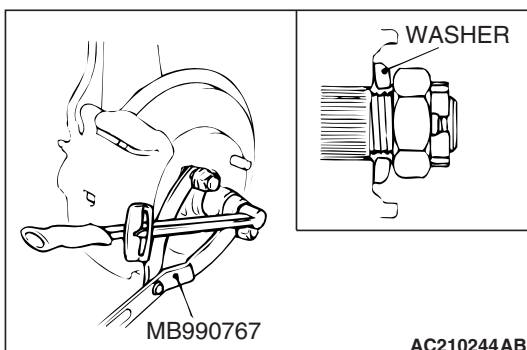

DISASSEMBLY AND ASSEMBLY <2.4L ENGINE>

CAUTION

- Be careful not to damage the ABS rotor, which is attached to the BJ outer race during disassembly and reassembly.
- Never disassemble the BJ assembly except when replacing the BJ boot.

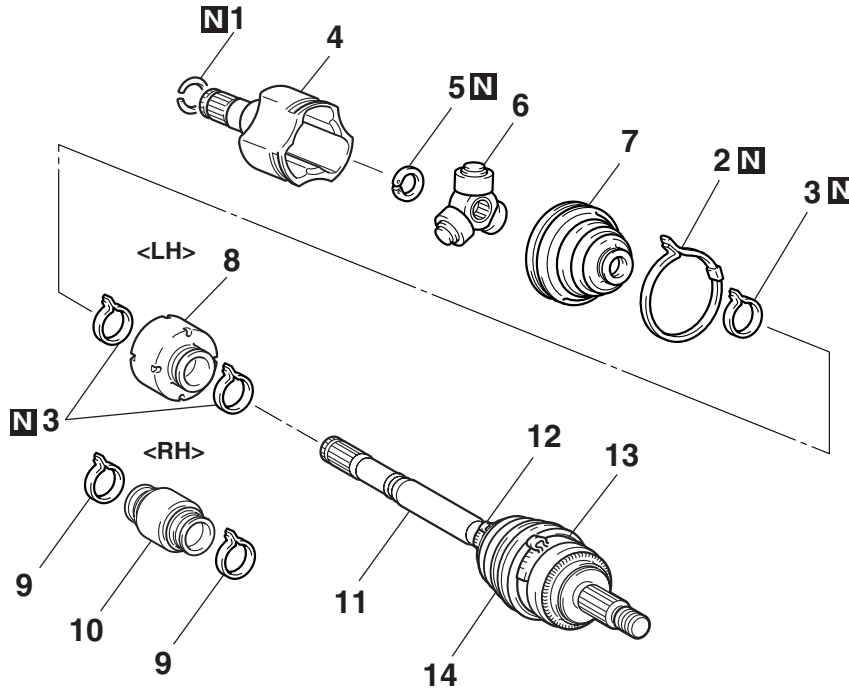

AC405415 AB

<p>TJ BOOT REPAIR KIT</p>	<p>TJ REPAIR KIT</p>	<p>BJ BOOT REPAIR KIT</p>

DISASSEMBLY STEPS

1. CIRCLIP
- >>D<< 2. TJ BOOT BAND (LARGE)
- >>D<< 3. TJ BOOT BAND (SMALL)
- <<A>> >>C<< 4. TJ CASE
5. SNAP RING
- <<A>> >>B<< 6. SPIDER ASSEMBLY
- <> >>A<< 7. TJ BOOT
- >>A<< 8. DYNAMIC DAMPER <LH>
- >>A<< 9. DAMPER BAND <RH>
- >>A<< 10. DYNAMIC DAMPER <RH>

DISASSEMBLY STEPS

11. BJ ASSEMBLY
12. BJ BOOT BAND (SMALL)
13. BJ BOOT BAND (LARGE)
14. BJ BOOT

NOTE:

For BJ boot removal and installation, refer to P.26-30.

LUBRICATION POINTS

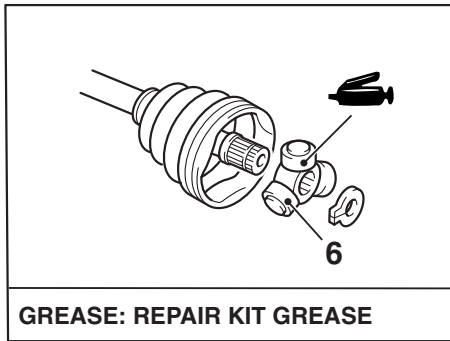

GREASE: REPAIR KIT GREASE

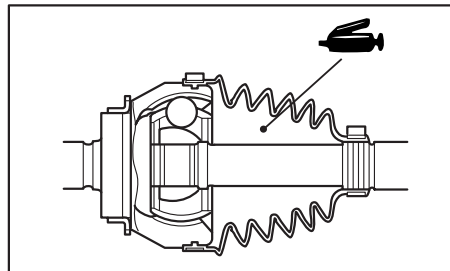

GREASE: REPAIR KIT GREASE
AMOUNT USED: 120 ± 10 g
(4.2 ± 0.3 oz)

CAUTION

THE DRIVE SHAFT JOINT USES SPECIAL GREASE. DO NOT MIX OLD AND NEW OR DIFFERENT TYPES OF GREASE.

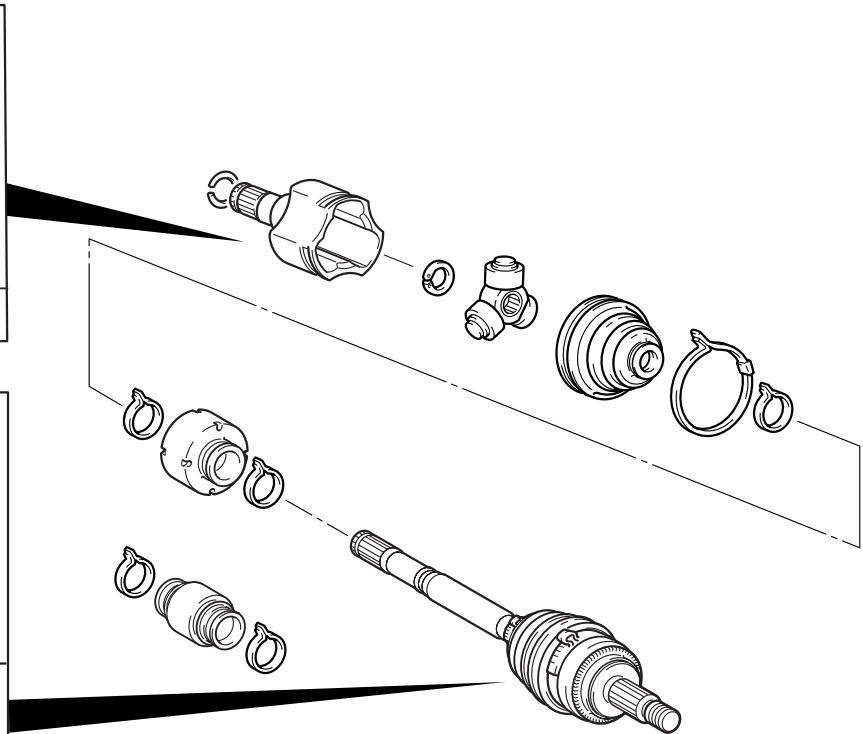

AC405441AB

DISASSEMBLY SERVICE POINTS

<<A>> TJ CASE/SPIDER ASSEMBLY REMOVAL

CAUTION

Do not disassemble the spider assembly.

1. Wipe off grease from the spider assembly and the inside of the TJ case.
2. Clean the spider assembly if water or foreign material is observed.

<> TJ BOOT REMOVAL

1. Wipe off grease from the shaft spline.
2. When reusing the TJ boot, wrap plastic tape around the shaft spline to avoid damaging the boot.

ASSEMBLY SERVICE POINTS**>>A<< DYNAMIC DAMPER <LH/RH>/DAMPER BAND <RH>/TJ BOOT INSTALLATION****⚠ CAUTION**

There should be no grease adhered to the rubber part of the dynamic damper.

1. Install the dynamic damper in the position (L) shown in the illustration.

L: 260 ± 3 mm (10.2 ± 0.12 inches) <LH>

L: 406 ± 3 mm (16.0 ± 0.12 inches) <RH>

2. Secure the damper bands.

3. Wrap plastic tape around the shaft spline, and then install the TJ boot band (small) and TJ boot.

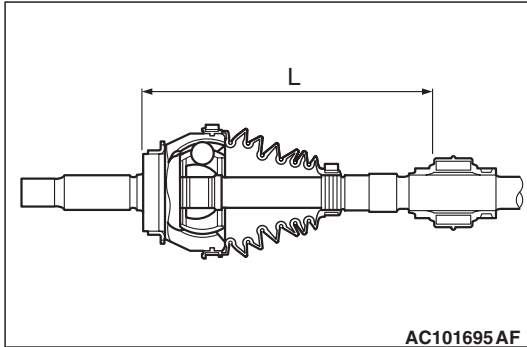
**>>B<< SPIDER ASSEMBLY INSTALLATION****⚠ CAUTION**

- The drive shaft joint use special grease. Do not mix old and new or different types of grease.
- If the spider assembly has been cleaned, take special care to apply the specified grease.

1. Apply the specified grease furnished in the repair kit to the spider assembly between the spider axle and the roller.

Specified grease: Repair kit grease

2. Install the spider assembly to the shaft from the direction of the spline chamfered side.

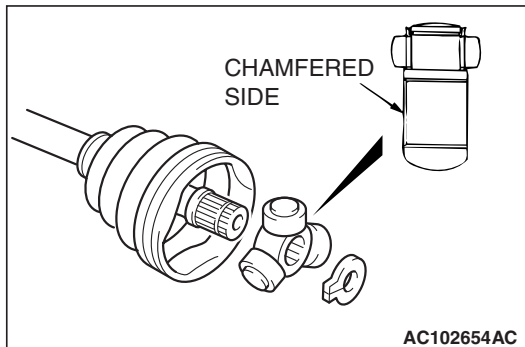

>>C<< TJ CASE INSTALLATION

⚠ CAUTION

The drive shaft joint use special grease. Do not mix old and new or different types of grease.

After applying the specified grease to the TJ case or PTJ case, insert the drive shaft and apply grease again.

Specified grease: Repair kit grease

Amount to use <LH>: 140 ± 10 g (4.9 ± 0.3 ounces)

Amount to use <RH>: 130 ± 10 g (4.6 ± 0.3 ounces)

NOTE: The grease in the repair kit should be divided in half for use, respectively, at the joint and inside the boot.

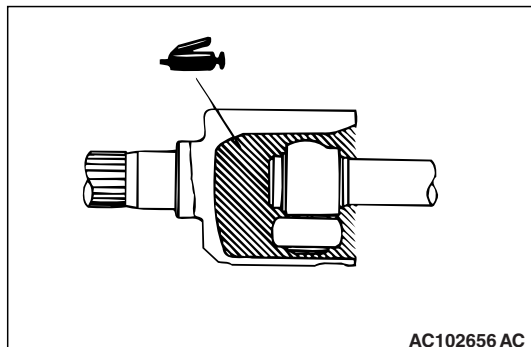

>>D<< TJ BOOT BAND (SMALL) /TJ BOOT BAND (LARGE) INSTALLATION

Set the TJ boot bands at the specified distance in order to adjust the amount of air inside the TJ boot, and then tighten the TJ boot band (small), TJ boot band (large) securely.

Standard value (A): 85 ± 3 mm (3.35 ± 0.12 inches)

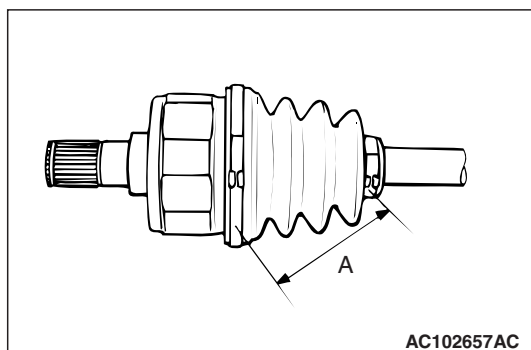

DISASSEMBLY AND ASSEMBLY <3.8L ENGINE>

M1261003700939

CAUTION

- Be careful not to damage the ABS rotor, which is attached to the EBJ outer race during disassembly and reassembly.
- Never disassemble the EBJ assembly except when replacing the EBJ boot.

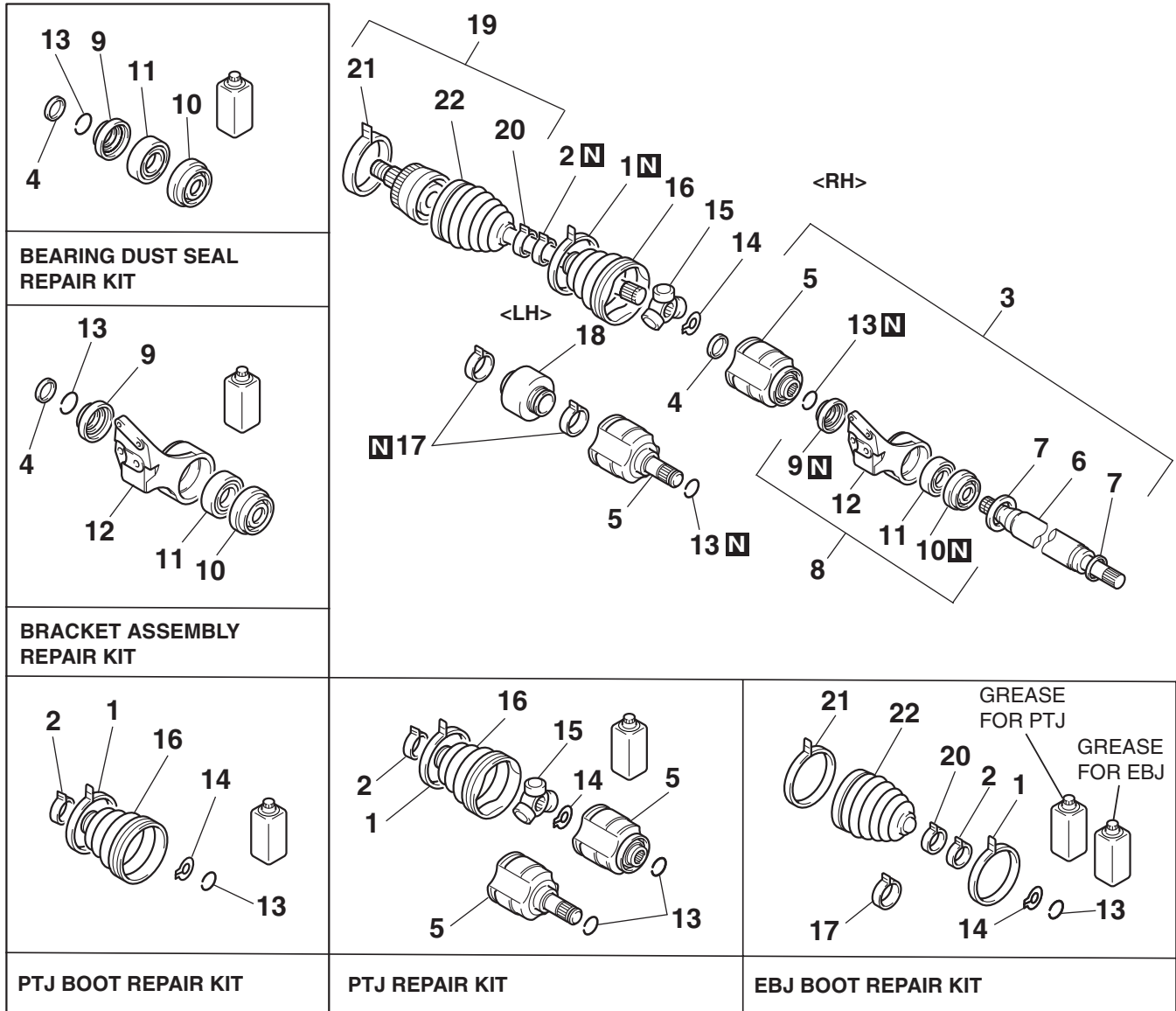

AC405627AB

- DISASSEMBLY STEPS**
- >>H<< 1. PTJ BOOT BAND (LARGE)
 - >>H<< 2. PTJ BOOT BAND (SMALL)
 - >>F<< 3. PTJ CASE AND INNER SHAFT ASSEMBLY
 - <<A>> >>F<< 4. SEAL PLATE
 - <> >>G<< 5. PTJ CASE
 - <<C>> >>E<< 6. INNER SHAFT
 - 7. DUST COVER
 - 8. BRACKET ASSEMBLY
 - >>D<< 9. DUST SEAL OUTER
 - >>D<< 10. DUST SEAL INNER

- DISASSEMBLY STEPS**
- <<D>> >>C<< 11. CENTER BEARING
 - 12. CENTER BEARING BRACKET
 - 13. CIRCLIP
 - 14. SNAP RING
 - <> >>B<< 15. SPIDER ASSEMBLY
 - <<E>> >>A<< 16. PTJ BOOT
 - >>A<< 17. DAMPER BAND
 - >>A<< 18. DYNAMIC DAMPER
 - 19. EBJ ASSEMBLY
 - 20. EBJ BOOT BAND (SMALL)
 - 21. EBJ BOOT BAND (LARGE)
 - 22. EBJ BOOT

NOTE:

*For EBJ boot removal and installation, refer to
[P.26-30](#).*

Required Special Tools:

- MB990810: Side Bearing Puller
- MB990890: Rear Suspension Bushing Base
- MB990930: Installer Adapter
- MB990932: Installer Adapter
- MB990934: Installer Adapter
- MB990938: Bar (snap-in type)
- MB991172: Inner Shaft Installer Base
- MB991248: Inner Shaft Remover
- MD998369: Bearing Installer

LUBRICATION POINTS

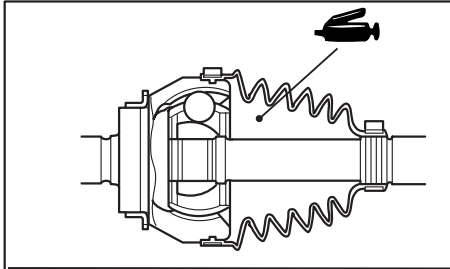

GREASE: REPAIR KIT GREASE
AMOUNT USED: 155 ± 10 g
(5.5 ± 0.3 oz)

CAUTION

THE DRIVE SHAFT JOINT USES SPECIAL GREASE. DO NOT MIX OLD AND NEW OR DIFFERENT TYPES OF GREASE.

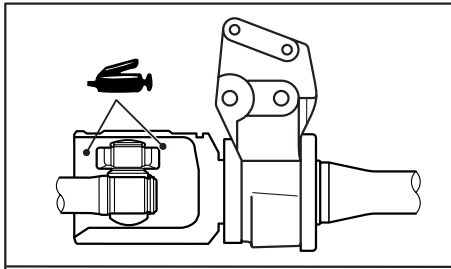

GREASE: REPAIR KIT GREASE
AMOUNT USED: 260 ± 10 g
(9.2 ± 0.3 oz)<M/T-LH>, 245 ± 10 g
(8.6 ± 0.3 oz)<A/T, MT-RH>

CAUTION

THE DRIVE SHAFT JOINT USES SPECIAL GREASE. DO NOT MIX OLD AND NEW OR DIFFERENT TYPES OF GREASE.

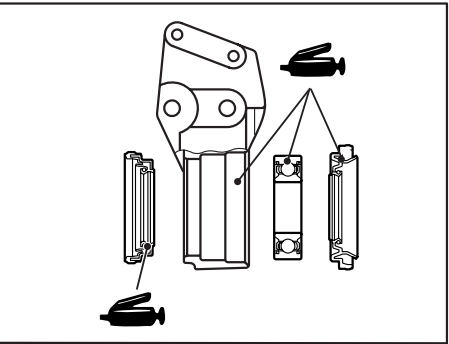

GREASE: REPAIR KIT GREASE
AMOUNT USED:
DUST SEAL INNER: 14 - 20 g
(0.5 - 0.7 oz)
DUST SEAL OUTER: 8 - 12 g
(0.3 - 0.4 oz)

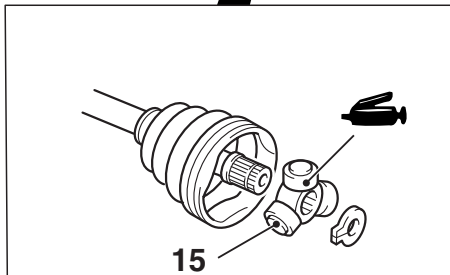
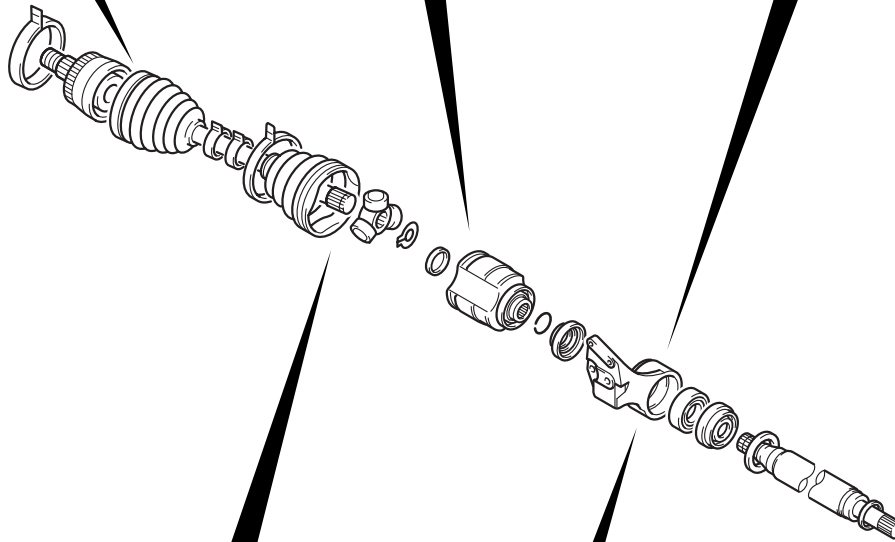

GREASE: REPAIR KIT GREASE

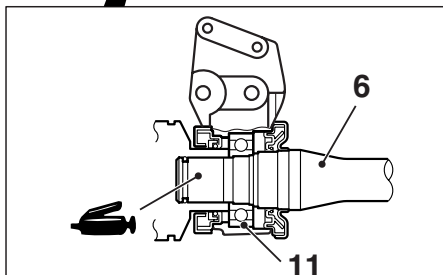

GREASE: REPAIR KIT GREASE

DISASSEMBLY SERVICE POINTS

<<A>> SEAL PLATE REMOVAL

Use a slotted screwdriver to make a hole in the seal plate inside the PTJ case, and remove it.

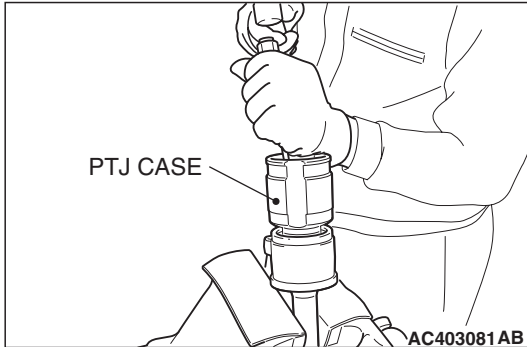

<> PTJ CASE/SPIDER ASSEMBLY REMOVAL

CAUTION

Do not disassemble the spider assembly.

1. Wipe off grease from the spider assembly and the inside of the PTJ case.
2. Clean the spider assembly if water or foreign material is observed.

<<C>> INNER SHAFT REMOVAL

1. Use special tool MB991248 to remove the inner shaft assembly from the PTJ case.

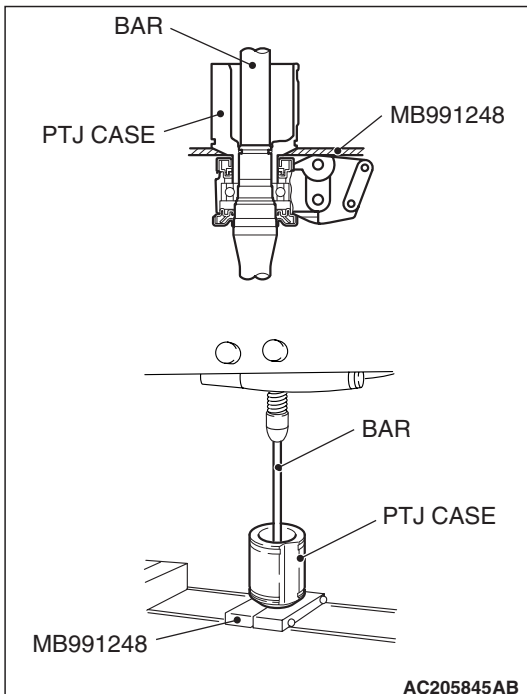

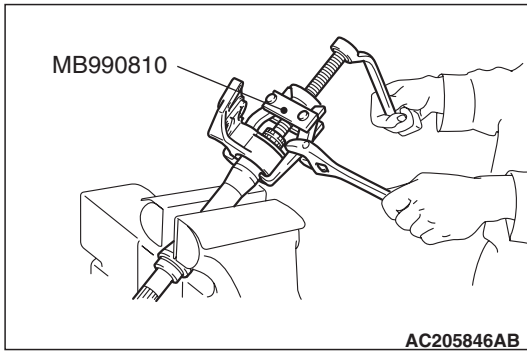

2. Use special tool MB990810 to remove the center bearing bracket from the inner shaft.

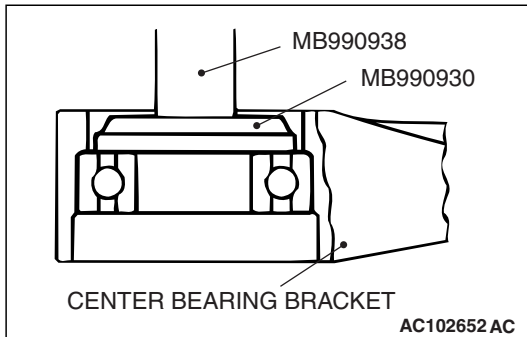

<<D>> CENTER BEARING REMOVAL

Use special tools MB990938 and MB990930 to remove the center bearing from the center bearing bracket.

<<E>> PTJ BOOT REMOVAL

1. Wipe off grease from the shaft spline.
2. When reusing the TJ boot or PTJ boot, wrap plastic tape around the shaft spline to avoid damaging the boot.

ASSEMBLY SERVICE POINTS

>>A<< DYNAMIC DAMPER/DAMPER BAND/PTJ BOOT INSTALLATION

⚠ CAUTION

There should be no grease adhered to the rubber part of the dynamic damper.

1. Install the dynamic damper in the position (L) shown in the illustration.

L: 260.5 ± 3 mm (10.3 ± 0.12 inches) <A/T>

L: 226 ± 3 mm (8.9 ± 0.12 inches) <M/T>

2. Secure the damper bands.
3. Wrap plastic tape around the shaft spline, and then install the PTJ boot band (small) and PTJ boot.

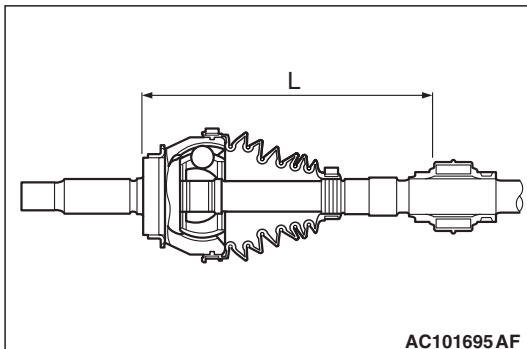

>>B<< SPIDER ASSEMBLY INSTALLATION

CAUTION

- The drive shaft joint use special grease. Do not mix old and new or different types of grease.
- If the spider assembly has been cleaned, take special care to apply the specified grease.

1. Apply the specified grease furnished in the repair kit to the spider assembly between the spider axle and the roller.

Specified grease: Repair kit grease

2. Install the spider assembly to the shaft from the direction of the spline chamfered side.

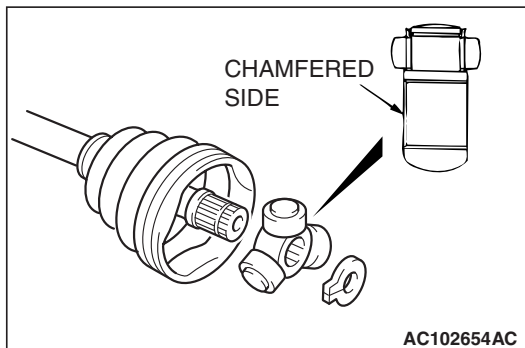

>>C<< CENTER BEARING INSTALLATION

Use special tools MB990938 and MB990932 to press-fit the center bearing into the center bearing bracket.

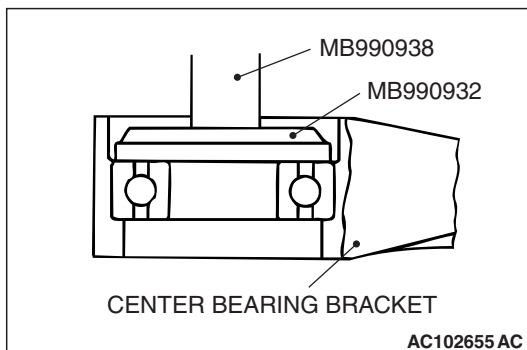

>>D<< DUST SEAL INNER/DUST SEAL OUTER INSTALLATION

CAUTION

When applying grease, make sure that it does not adhere to anything outside the lip.

1. Apply the specified grease to the rear surface of all dust seals.

Specified grease: Repair kit grease

Amount used (Dust seal inner): 14 – 20 g (0.5 – 0.7 ounce)

Amount used (Dust seal outer): 8 – 12 g (0.3 – 0.4 ounce)

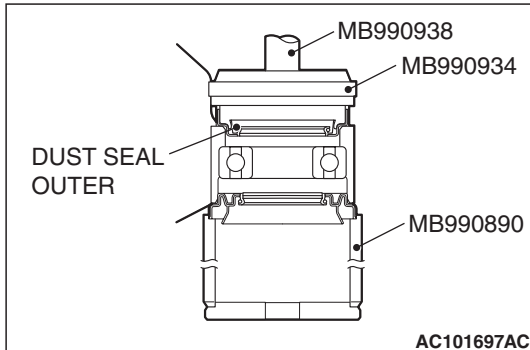
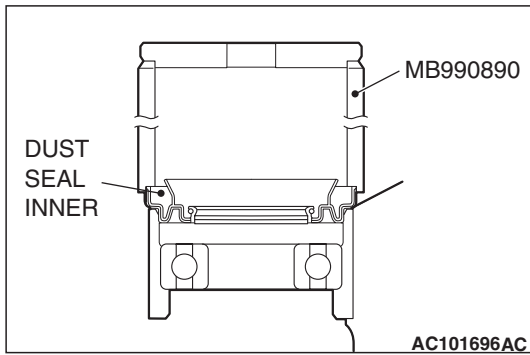

2. Use special tools MB990890, MB990938, and MB990934 to press the dust seals into the center bearing bracket until they are flush with each other.
3. Apply repair kit grease to the lip of each dust seal.

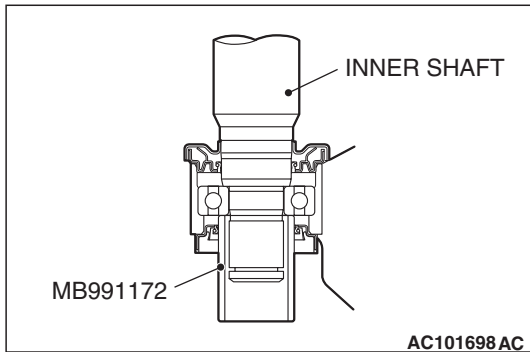

>>E<<INNER SHAFT INSTALLATION

Use special tool MB991172 to hold the center bearing inner race, and then press-in the inner shaft.

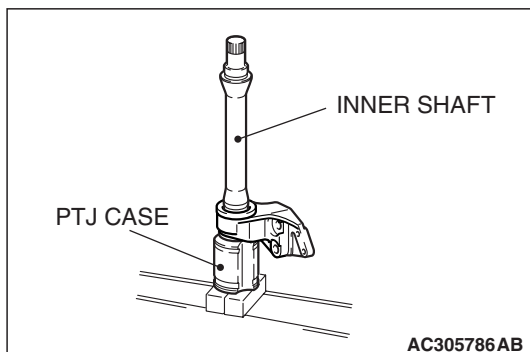

>>F<<SEAL PLATE/PTJ CASE AND INNER SHAFT ASSEMBLY INSTALLATION

1. Apply repair kit grease to the inner shaft spline, then press fit it into the PTJ case.

NOTE: When press-fitting the inner shaft into the PTJ case, apply a thin coat of repair kit grease to the dust seal outer lip part and the outside edge of the PTJ axial part.

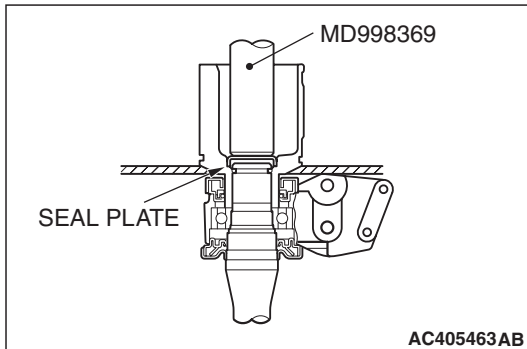

2. Use special tool MD998369 to press in the seal plate.

>>G<< PTJ CASE INSTALLATION

⚠ CAUTION

The drive shaft joint uses special grease. Do not mix old and new or different types of grease.

After applying the specified grease to the PTJ case, insert the drive shaft and apply grease again.

Specified grease: Repair kit grease

Amount to use <M/T-LH>: 260 ± 10 g (9.2 ± 0.3 ounces)

Amount to use <A/T, M/T-RH>: 245 ± 10 g (8.6 ± 0.3 ounces)

NOTE: The grease in the repair kit should be divided in half for use, respectively, at the joint and inside the boot.

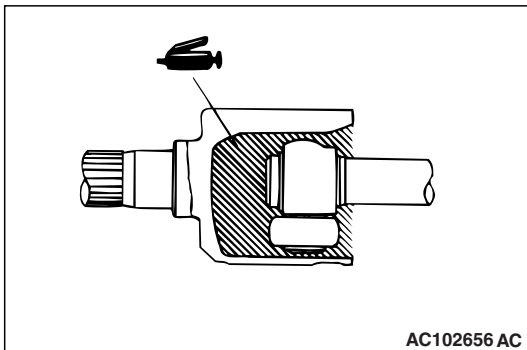

>>H<< PTJ BOOT BAND (SMALL)/PTJ BOOT BAND (LARGE) INSTALLATION

Set the PTJ boot bands at the specified distance in order to adjust the amount of air inside the PTJ boot, and then tighten the PTJ boot band (small), PTJ boot band (large) securely.

Standard value (A): 85 ± 3 mm (3.35 ± 0.12 inches)

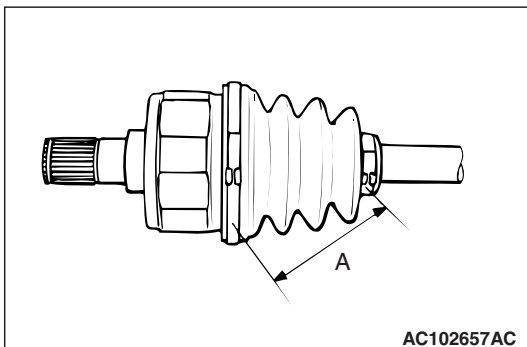

INSPECTION

M1261003800163

- Check the drive shaft for damage, bending or corrosion.
- Check the inner shaft for damage, bending or corrosion.
- Check the drive shaft spline part for wear or damage.
- Check the inner shaft spline part for wear or damage.
- Check the spider assembly for roller rotation, wear or corrosion.
- Check the groove inside TJ case or PTJ case for wear or corrosion.
- Check the boots for deterioration, damage or cracking.

- Check the center bearing for seizure, discoloration or roughness of rolling surface.
- Check the dust cover for damage or deterioration.

BJ/EBJ BOOT REPLACEMENT

M1261005200543

Required Special Tool:

MB991561:Boot Band Crimping Tool

1. Remove the boot bands (large and small).

NOTE: The boot bands cannot be re-used.

2. Remove the BJ/EBJ boot.
3. Wrap a plastic tape around the shaft spline, and assemble the boot band and BJ/EBJ boot.

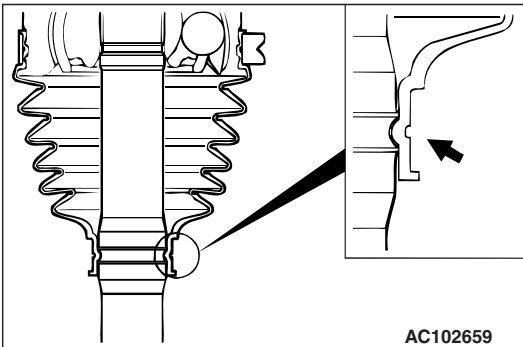
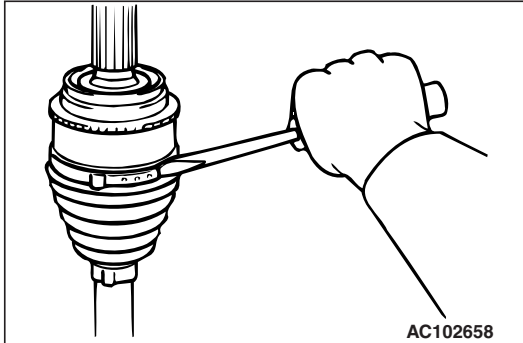

4. Align the center groove on the BJ/EBJ boot small end with the shaft groove.

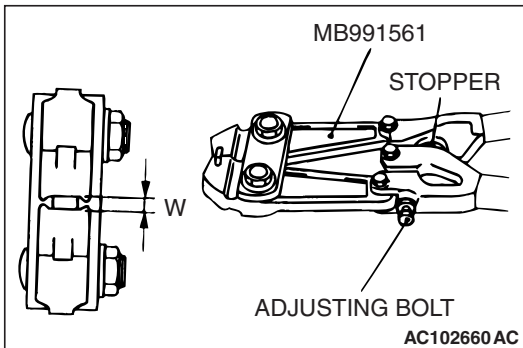

5. Turn the adjusting bolt on special tool MB991561 so that the size of the opening (W) is at the standard value.

Standard value (W): 2.9 mm (0.11 inch)

<If it is larger than 2.9 mm (0.11 inch)> Tighten the adjusting bolt.

<If it is smaller than 2.9 mm (0.11 inch)> Loosen the adjusting bolt.

NOTE: The value of W will change by approximately 0.7 mm (0.03 inch) for each turn of the adjusting bolt.

NOTE: The adjusting bolt should not be turned more than once.

6. Position the BJ/EBJ boot band (small) so that there is even clearance at either end (A and B).

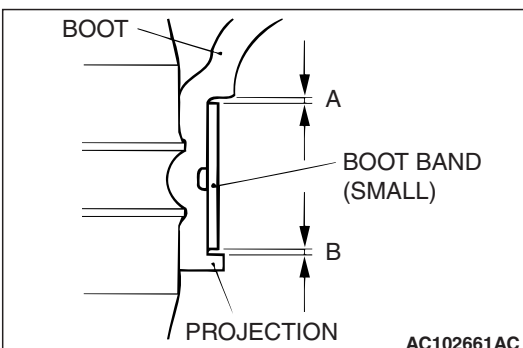

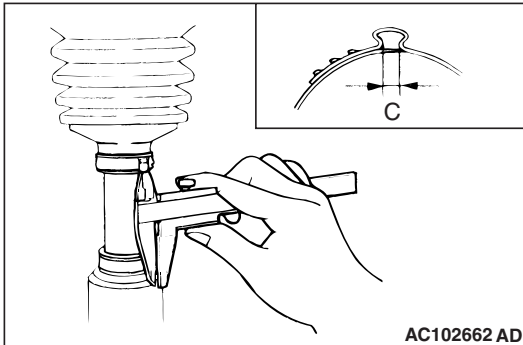
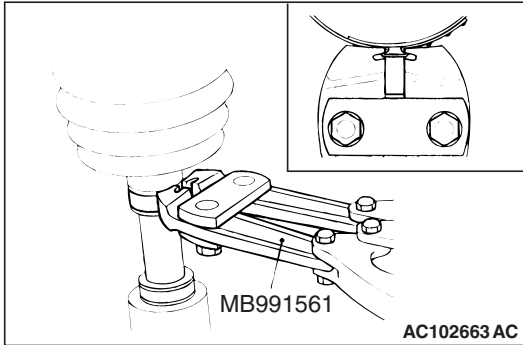

⚠ CAUTION

- Secure the drive shaft in an upright position and clamp part of the boot band to be crimped securely in the jaws of special tool MB991561.
 - Crimp the boot band until the special tool touches the stopper.
7. Use special tool MB991561 to crimp the boot band (small).

8. Check that the crimping amount (C) of the boot band is at the standard value.

Standard value (D): 2.4 – 2.8 mm (0.09 – 0.11 inch)

<If the crimping amount is larger than 2.8 mm (0.11 inch)>

Readjust the value of (W) in step 5 according to the following formula, and then repeat the operation in step 7.

$W = 5.5 \text{ mm (0.22 inch)} - D$

Example: If $D = 2.9 \text{ mm (0.11 inch)}$, then $W = 2.6 \text{ mm (0.10 inch)}$.

<If the crimping amount is smaller than 2.4 mm (0.09 inch)>

Remove the BJ/EBJ boot band, readjust the value of (W) in step 5 according to the following formula, and then repeat the operations in steps 6 and 7 using a new BJ/EBJ boot band.

$W = 5.5 \text{ mm (0.22 inch)} - D$

Example: If $D = 2.3 \text{ mm (0.09 inch)}$, then $W = 3.2 \text{ mm (0.13 inch)}$.

9. Check that the boot band does not stick out past the place where it has been installed. If the boot band sticks out, remove it and then repeat steps 6 to 8, using a new boot band.

⚠ CAUTION

The drive shaft joint uses special grease. Do not mix old and new or different types of grease.

10. Fill the inside of the boot with the specified amount of the specified grease.

Specified grease: Repair kit grease

Amount to use (BJ) <2.4L>: $120 \pm 10 \text{ g (4.2} \pm 0.3 \text{ ounces)}$

Amount to use (EBJ) <3.8L>: $155 \pm 10 \text{ g (5.5} \pm 0.3 \text{ ounces)}$

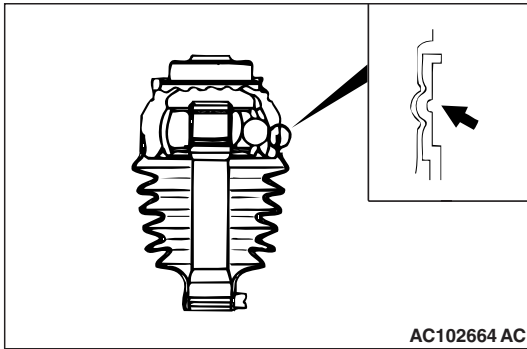

11. Align the center groove on the BJ/EBJ boot big end with the BJ/EBJ case groove.

12. Follow the same procedure as in step 5 to adjust the size of the opening (W) on special tool so that it is at the standard value.

Standard value (W): 2.9 mm (0.11 inch)

13. Position the BJ/EBJ boot band (large) so that there is even clearance at either end (D and E).

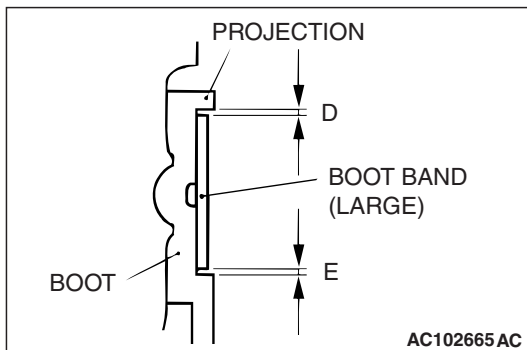

14. Use special tool to crimp the BJ/EBJ boot band (large) in the same way as in step 7.

15. Check that the crimping amount (F) of the boot band is at the standard value.

Standard value (F): 2.4 – 2.8 mm (0.09 – 0.11 inch)

<If the crimping amount is larger than 2.8 mm (0.11 inch)>

Readjust the value of (W) in step 12 according to the following formula, and then repeat the operation in step 14.

$$W = 5.8 \text{ mm (0.23 inch)} - F$$

Example: If $F = 2.9 \text{ mm (0.11 inch)}$, then $W = 2.9 \text{ mm (0.11 inch)}$.

<If the crimping amount is smaller than 2.4 mm (0.09 inch)>

Remove the EBJ/EBJ boot band, readjust the value of (W) in step 12 according to the following formula, and then repeat the operations in steps 13 and 14 using a new EBJ/EBJ boot band.

$$W = 5.8 \text{ mm (0.23 inch)} - F$$

Example: If $F = 2.3 \text{ mm (0.09 inch)}$, then $W = 3.5 \text{ mm (0.14 inch)}$.

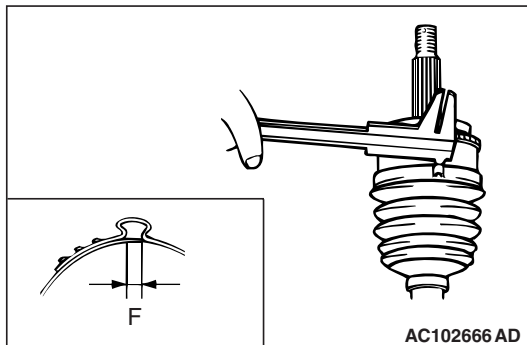

16. Check that the boot band does not stick out past the place where it has been installed. If the boot band sticks out, remove it and then repeat steps 13 to 15, using a new boot band.

SPECIFICATIONS

FASTENER TIGHTENING SPECIFICATIONS

M1261005400309

ITEM	SPECIFICATION
Caliper assembly bolt	100 ± 10 N· m (74 ± 7 ft-lb)
Center bearing bracket bolt <3.8L-RH>	41 ± 4 N· m (30 ± 3 ft-lb)
Drive shaft nut	226 ± 29 N· m (167 ± 21 ft-lb)
Dust cover bolt	9.0 ± 2.0 N· m (80 ± 17 in-lb)
Front strut nut	305 ± 25 N· m (225 ± 18 ft-lb)
Front wheel hub bolt	90 ± 10 N· m (67 ± 7 ft-lb)
Self-locking nut (lower arm ball joint connection)	65 ± 6 N· m (48 ± 4 ft-lb)
Self-locking nut (tie rod end connection)	29 ± 4 N· m (21 ± 3 ft-lb)

GENERAL SPECIFICATIONS

M1261000200355

ITEM			SPECIFICATION
Wheel bearing	Type		Unit ball bearing (Double-row angular contact ball bearing)
Drive shaft	Joint type	Outer	BJ (Birfield Joint) <2.4L engine>, EBJ (Eight Ball Fixed Joint) <3.8L engine>
		Inner	TJ (Tripod Joint) <2.4L engine>, PTJ (Pillow Tripod Joint) <3.8L engine>

SERVICE SPECIFICATIONS

M1261000300619

ITEM	STANDARD VALUE	LIMIT
Wheel bearing end play mm (in)	–	0.05 (0.002)
Wheel bearing rotation starting torque N· m (in-lb)	–	1.4 (12)
Setting of TJ/PTJ boot length mm (in)	85 ± 3 (3.35 ± 0.12)	–
Opening dimension of the special tool (MB991561) mm (in)	When the BJ/EBJ boot band (small) is crimped	2.9 (0.11)
	When the BJ/EBJ boot band (large) is crimped	2.9 (0.11)
Crimped width of the BJ/EBJ boot band mm (in)	2.4 – 2.8 (0.09 – 0.11)	–

LUBRICANTS

M1261000400627

ITEM	SPECIFIED LUBRICANT		QUANTITY
TJ boot grease	Repair kit grease	2.4L engine-LH	140 ± 10 g (4.9 ± 0.3 oz)
		2.4L engine-RH	130 ± 10 g (4.6 ± 0.3 oz)
PTJ boot grease	Repair kit grease	3.8L engine-M/T-LH	260 ± 10 g (9.2 ± 0.3 oz)
		3.8L engine-A/T, 3.8L engine-M/T-RH	245 ± 10 g (8.6 ± 0.3 oz)
BJ boot grease	Repair kit grease	2.4L engine	120 ± 10 g (4.2 ± 0.3 oz)
EBJ boot grease	Repair kit grease	3.8L engine	155 ± 10 g (5.5 ± 0.3 oz)
Dust seal inner grease	Repair kit grease		14 – 20 g (0.5 – 0.7 oz)
Dust seal outer grease	Repair kit grease		8 – 12 g (0.3 – 0.4 oz)