

## GROUP 37

## POWER STEERING

## CONTENTS

<b>GENERAL DESCRIPTION</b> . . . . .	<b>37-3</b>	STATIONARY STEERING EFFORT CHECK . . . . .	37-20
<b>POWER STEERING DIAGNOSIS</b> . . .	<b>37-5</b>	STEERING WHEEL RETURN TO CENTER CHECK . . . . .	37-21
INTRODUCTION TO POWER STEERING DIAGNOSIS . . . . .	37-5	DRIVE BELT TENSION CHECK . . . . .	37-21
POWER STEERING DIAGNOSIS TROUBLESHOOTING STRATEGY . . . . .	37-5	FLUID LEVEL CHECK . . . . .	37-21
SYMPTOM CHART . . . . .	37-5	FLUID REPLACEMENT . . . . .	37-22
SYMPTOM PROCEDURES . . . . .	37-6	POWER STEERING SYSTEM AIR BLEEDING . . . . .	37-22
<b>SPECIAL TOOLS</b> . . . . .	<b>37-15</b>	OIL PUMP PRESSURE TEST . . . . .	37-23
<b>ON-VEHICLE SERVICE</b> . . . . .	<b>37-19</b>	POWER STEERING PRESSURE SWITCH CHECK . . . . .	37-24
STEERING WHEEL FREE PLAY CHECK . . . . .	37-19	TIE ROD END BALL JOINT DUST COVER CHECK . . . . .	37-25
STEERING ANGLE CHECK . . . . .	37-19	STEERING COLUMN SHAFT ASSEMBLY SHOCK ABSORBING MECHANISM CHECK . . . . .	37-25
TIE ROD END BALL JOINT BREAKAWAY TORQUE CHECK . . . . .	37-19		

Continued on next page

## WARNINGS REGARDING SERVICING OF SUPPLEMENTAL RESTRAINT SYSTEM (SRS) EQUIPPED VEHICLES

 **WARNING**

- *Improper service or maintenance of any component of the SRS, or any SRS-related component, can lead to personal injury or death to service personnel (from inadvertent firing of the air bag) or to the driver and passenger (from rendering the SRS inoperative).*
- *Service or maintenance of any SRS component or SRS-related component must be performed only at an authorized MITSUBISHI dealer.*
- *MITSUBISHI dealer personnel must thoroughly review this manual, and especially its GROUP 52B - Supplemental Restraint System (SRS) before beginning any service or maintenance of any component of the SRS or any SRS-related component.*

## NOTE

The SRS includes the following components: SRS air bag control unit, SRS warning light, front impact sensors, air bag module, clock spring, and interconnecting wiring. Other SRS-related components (that may have to be removed/installed in connection with SRS service or maintenance) are indicated in the table of contents by an asterisk (\*).

<b>STEERING WHEEL*</b> .....	<b>37-27</b>	REMOVAL AND INSTALLATION	
REMOVAL AND INSTALLATION .....	37-27	<2.4L ENGINE> .....	37-56
<b>STEERING SHAFT*</b> .....	<b>37-29</b>	REMOVAL AND INSTALLATION	
REMOVAL AND INSTALLATION .....	37-29	<3.8L ENGINE> .....	37-57
DISASSEMBLY AND ASSEMBLY .....	37-32	INSPECTION .....	37-58
<b>POWER STEERING GEAR BOX AND LINKAGE*</b> .....	<b>37-34</b>	<b>POWER STEERING HOSES</b> .....	<b>37-59</b>
REMOVAL AND INSTALLATION .....	37-34	REMOVAL AND INSTALLATION .....	37-59
INSPECTION .....	37-41	<b>SPECIFICATIONS</b> .....	<b>37-65</b>
DISASSEMBLY AND ASSEMBLY .....	37-42	FASTENER TIGHTENING	
INSPECTION .....	37-54	SPECIFICATIONS .....	37-65
<b>POWER STEERING OIL PUMP ASSEMBLY</b> .....	<b>37-56</b>	GENERAL SPECIFICATIONS .....	37-66
		SERVICE SPECIFICATIONS .....	37-67
		LUBRICANTS .....	37-67
		SEALANT .....	37-67

## GENERAL DESCRIPTION

M1372000100586

All vehicles are equipped with power steering.

- A 4-spoke steering wheel is used.
- The steering column has a shock absorbing mechanism and a tilt steering mechanism.
- A rack and pinion steering gear is used.

- An oil pump responsive to engine RPM is used for stable steering at high speeds.
- The separate plastic resin oil reservoir reduces weight and to make the fluid level checking easier.

<2.4L ENGINE>

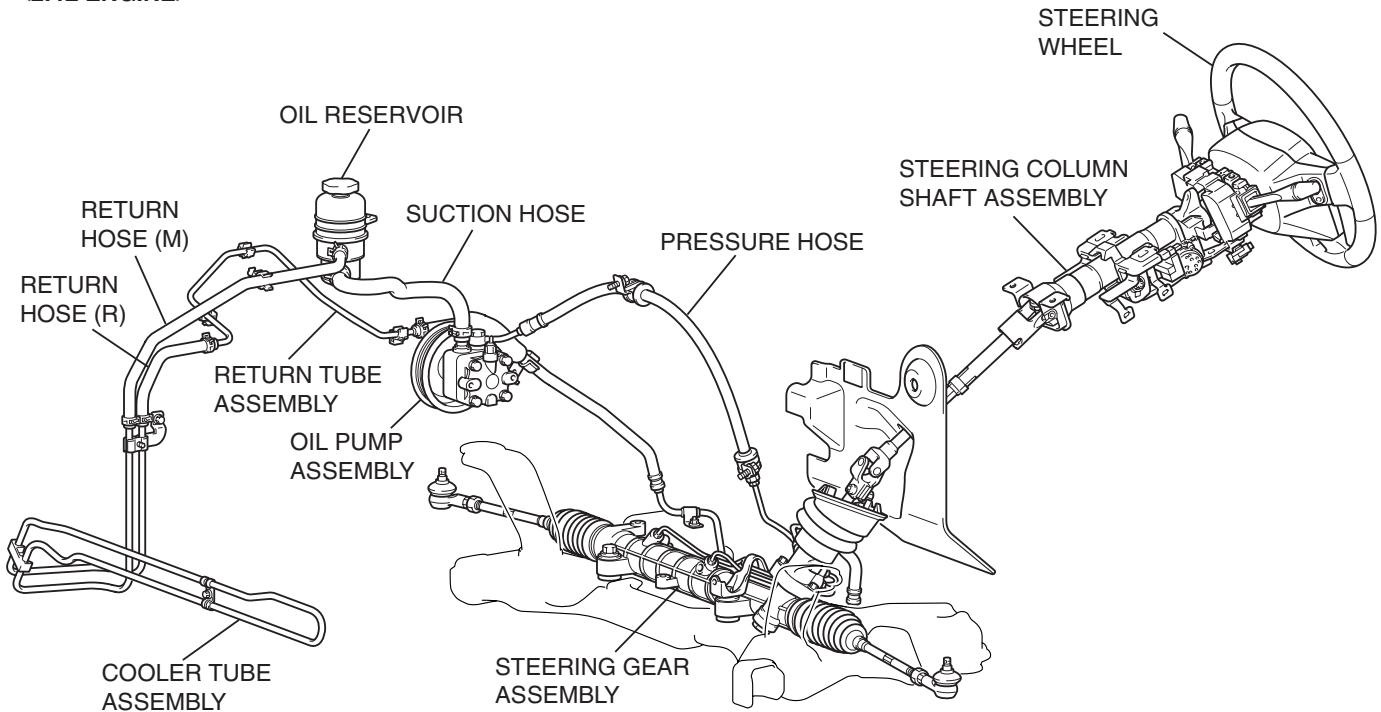

AC405729AB

<3.8L ENGINE>

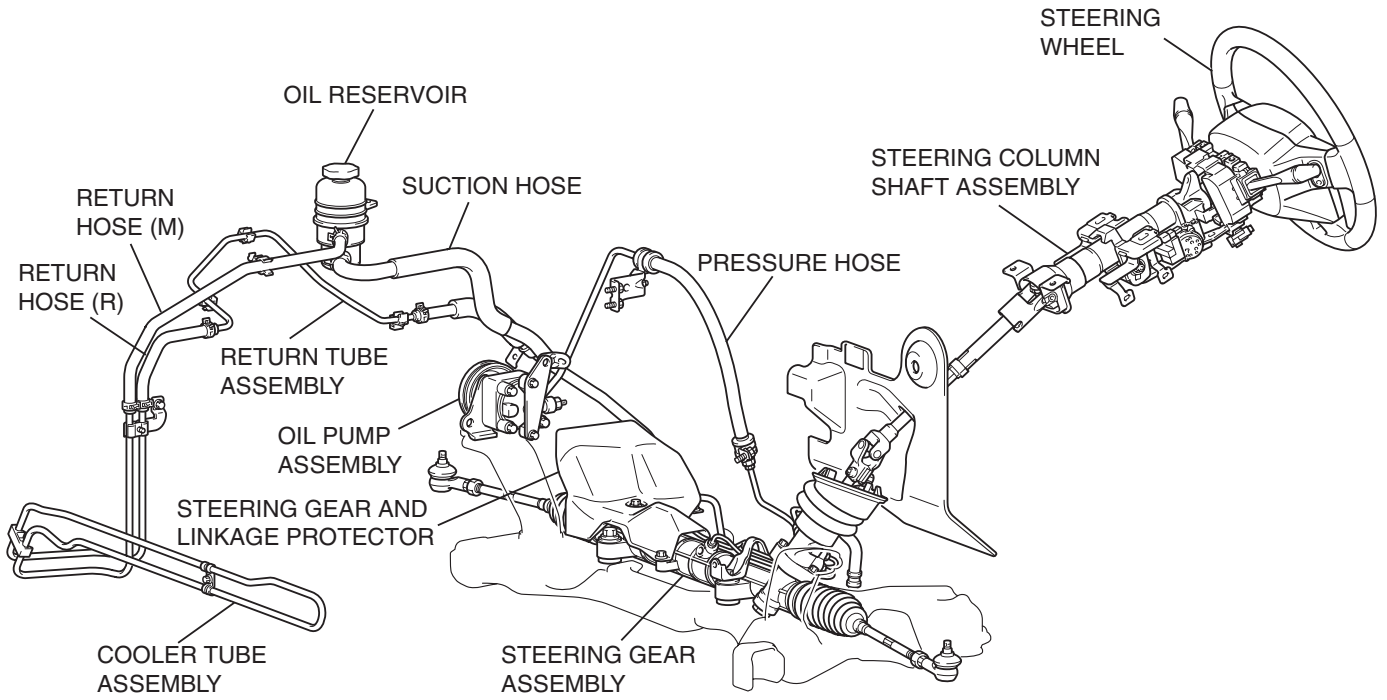

AC405711AB

## POWER STEERING DIAGNOSIS

### INTRODUCTION TO POWER STEERING DIAGNOSIS

M1372008500243

Hydraulic power steering is used for all vehicles. Faults in the power steering can include excessive play of the steering wheel, difficult steering wheel operation, noise, vibration, and oil leaks, etc. Possible causes of these faults include defects in the gear box, oil pump or steering linkage.

### POWER STEERING DIAGNOSIS TROUBLESHOOTING STRATEGY

M1372007300202

Use these steps to plan your diagnostic strategy. If you follow them thoroughly, you will be sure that you have exhausted most of the possible ways to find a power steering fault.

1. Gather information from the customer.

2. Verify that the condition described by the customer exists.
3. Find the malfunction by following the Symptom Chart.
4. Verify malfunction is eliminated.

### SYMPTOM CHART

M1372007600225

SYMPTOM	INSPECTION PROCEDURE	REFERENCE PAGE
Excessive play of steering wheel	1	<a href="#">P.37-6</a>
Difficult steering wheel operation (insufficient power assist)	2	<a href="#">P.37-7</a>
Rattling noise	3	<a href="#">P.37-8</a>
Shrill noise	4	<a href="#">P.37-9</a>
Squealing noise	5	<a href="#">P.37-9</a>
Hissing noise	6	<a href="#">P.37-10</a>
Droning noise	7	<a href="#">P.37-11</a>
Squeaking noise	8	<a href="#">P.37-11</a>
Vibration	9	<a href="#">P.37-12</a>
Oil leakage from hose connection	10	<a href="#">P.37-13</a>
Oil leakage from hose assembly	11	<a href="#">P.37-13</a>
Oil leakage from oil reservoir	12	<a href="#">P.37-13</a>
Oil leakage from oil pump	13	<a href="#">P.37-14</a>
Oil leakage from steering gear	14	<a href="#">P.37-14</a>

## SYMPTOM PROCEDURES

## INSPECTION PROCEDURE 1: Excessive Play of Steering Wheel

## DIAGNOSIS

**STEP 1. Check for looseness at the steering shaft coupling section and at the steering wheel linkage.**

**Q: Is there any looseness?**

**YES :** Repair or replace the part. And then go to Step 3.

**NO :** Go to Step 2.

**STEP 2. Check the steering wheel free play.**

(1) With the engine running (hydraulic operation), set the front wheels straight ahead.

(2) Slightly move the steering wheel in both directions, and measure the play on the steering wheel circumference before the wheels start to move.

**Limit: 30 mm (1.2 inch)**

(3) If the free play exceeds the limit, set the steering wheel straight ahead with the engine stopped. Apply approximately 5 N (1.1 pound) to the steering circumference and check the play.

**Standard value (steering wheel play with engine stopped): 10 mm (0.4 inch) or less**

**Q: Does the play exceed the standard value?**

**YES :** Remove the steering gear box (refer to [P.37-34](#)) and check the total pinion torque (refer to [P.37-42](#)). And then go to Step 3.

**NO :** Go to Step 3.

**STEP 3. Check the steering wheel play.**

Verify that the steering wheel play is not excessive.

**Q: Is the steering wheel play excessive?**

**YES :** Repeat from Step 1.

**NO :** The procedure is complete.

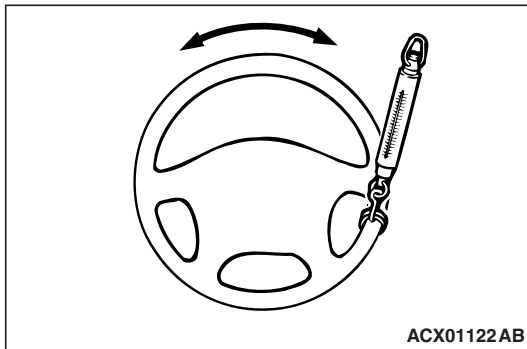

**INSPECTION PROCEDURE 2: Difficult Steering Wheel Operation (Insufficient Power Assist)**

**DIAGNOSIS**

**STEP 1. Check the drive belt for damage.**

**Q: Is the drive belt damaged?**

- YES** : Replace the drive belt. And then go to Step 9.  
**NO** : Go to Step 2.

**STEP 2. Check the power steering oil pump drive belt tension.**

Refer to GROUP 00, Maintenance Service –Drive Belts [P.00-52](#).

**Q: Is the power steering oil pump drive belt tension within the standard value?**

- YES** : Go to Step 3.  
**NO** : Adjust the tension (refer to GROUP 00, Maintenance Service –Drive Belts [P.00-52](#)). And then go to Step 9.

**STEP 3. Check the fluid level.**

- (1) Park the vehicle on a flat, level surface, and then start the engine.
- (2) Turn the steering wheel several times to raise the temperature of the fluid to approximately 50 –60° C (122 – 140° F).
- (3) With the engine running, turn the wheel all the way to the left and right several times.
- (4) Check the fluid in the oil reservoir for foaming or milkiness. Check the difference of the fluid level when the engine is stopped, and while it is running. If the fluid contains air or has milky appearance, or the fluid level fluctuate by 5 mm (0.2 inch) or more, power steering system air bleeding should be done.

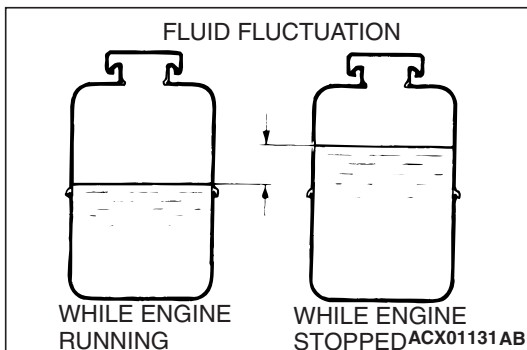

**Q: Is the check result OK?**

- YES** : Go to Step 4.  
**NO** : Bleed the air (refer to [P.37-22](#)). And then go to Step 9

**STEP 4. Check each hose for crushing or twisting.**

**Q: Is any hose crushed or twisted?**

- YES** : Repair or replace the hose. Then go to Step 9.  
**NO** : Go to Step 5.

**STEP 5. Check for oil leaks.**

**Q: Are there oil leaks?**

- YES** : Find the cause of the oil leakage and repair it. Then go to Step 9.  
**NO** : Go to Step 6.

**STEP 6. Check the wheel alignment (camber and caster).**  
Refer to GROUP 33, On-vehicle Service –Front Wheel Alignment Check and Adjustment [P.33-6](#).

**Q: Is the wheel alignment incorrect?**

**YES :** Adjust wheel alignment. Then go to Step 9.

**NO :** Go to Step 7.

**STEP 7. Check the gear box rack piston seal for damage.**

**Q: Is there damage?**

**YES :** Replace it. And then go to Step 9.

**NO :** Go to Step 8.

**STEP 8. Check for excessive tie rod end ball joint breakaway torque.**

Refer to [P.37-19](#).

**Q: Is the breakaway torque out of specification?**

**YES :** Replace the tie rod end. Then go to Step 9.

**NO :** Go to Step 9.

**STEP 9. Check the steering wheel operation.**

Verify that the steering wheel operation is not difficult.

**Q: Is the steering wheel operation difficult?**

**YES :** Repeat from Step 1.

**NO :** The procedure is complete.

### INSPECTION PROCEDURE 3: Rattling Noise

#### DIAGNOSIS

**STEP 1. Check for proper oil pump and steering gear installation.**

**Q: Is the oil pump and the steering gear installation correct?**

**YES :** Go to Step 2.

**NO :** Repair it. And then go to Step 4.

**STEP 2. Check for interference of other parts with the steering column and the power steering hoses.**

**Q: Is there interference?**

**YES :** Correct the interference. And then go to Step 4.

**NO :** Go to Step 3.

**STEP 3. Check for noise from inside the oil pump or the steering gear.**

**Q: Is there noise?**

**YES :** Replace the part. And then go to Step 4.

**NO :** Go to Step 4.

**STEP 4. Check for rattling noise.**

Confirm that no noise is generated.

**Q: Is there noise?**

**YES :** Repeat from Step 1.

**NO :** The procedure is complete.



**INSPECTION PROCEDURE 4: Shrill Noise**

**DIAGNOSIS**

**STEP 1. Check the fluid level.**

- (1) Park the vehicle on a flat, level surface, and then start the engine.
- (2) Turn the steering wheel several times to raise the temperature of the fluid to approximately 50 –60° C (122 – 140° F).
- (3) With the engine running, turn the wheel all the way to the left and right several times.
- (4) Check the fluid in the oil reservoir for foaming or milkiness. Check the difference of the fluid level when the engine is stopped, and while it is running. If the fluid contains air or has milky appearance, or the fluid level fluctuate by 5 mm (0.2 inch) or more, power steering system air bleeding should be done.

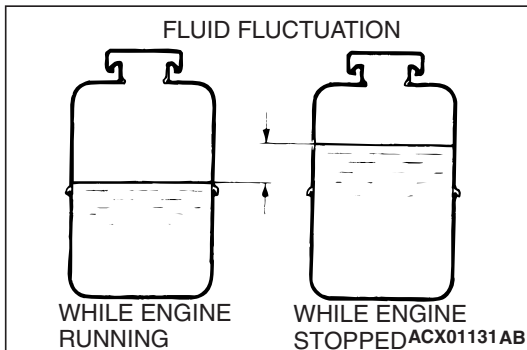

**Q: Is the check result OK?**

**YES :** Go to Step 2.

**NO :** Bleed the air (Refer to [P.37-22](#)). And then go to Step 3 .

**STEP 2. Check for seizure in the oil pump.**

**Q: Is there seizure?**

**YES :** Replace the part. And then go to Step 3.

**NO :** Go to Step 3.

**STEP 3. Retest the system.**

Confirm that no noise is generated.

**Q: Is there noise?**

**YES :** Repeat from Step 1.

**NO :** The procedure is complete.

**INSPECTION PROCEDURE 5: Squealing Noise**

**DIAGNOSIS**

**STEP 1. Check the drive belt tension.**

Refer to GROUP 00, Maintenance Service –Drive Belts [P.00-52](#).

**Q: Is the drive belt tension incorrect?**

**YES :** Adjust the belt tension. (Refer to GROUP 00, Maintenance Service –Drive Belts [P.00-52](#)). And then go to Step 3.

**NO :** Go to Step 2.

**STEP 2. Check for seizure in the oil pump.**

**Q: Is there seizure?**

**YES :** Replace the part. And then go to Step 3.

**NO :** Go to Step 3.

**STEP 3. Retest the system.**

Confirm that no noise is generated.

**Q: Is there noise?**

**YES :** Repeat from Step 1.

**NO :** The procedure is complete.

## INSPECTION PROCEDURE 6: Hissing Noise

## DIAGNOSIS

**STEP 1. Check the fluid level.**

- (1) Park the vehicle on a flat, level surface, and then start the engine.
- (2) Turn the steering wheel several times to raise the temperature of the fluid to approximately 50 –60° C (122 – 140° F).
- (3) With the engine running, turn the wheel all the way to the left and right several times.
- (4) Check the fluid in the oil reservoir for foaming or milkiness. Check the difference of the fluid level when the engine is stopped, and while it is running. If the fluid contains air or has milky appearance, or the fluid level fluctuate by 5 mm (0.2 inch) or more, power steering system air bleeding should be done.

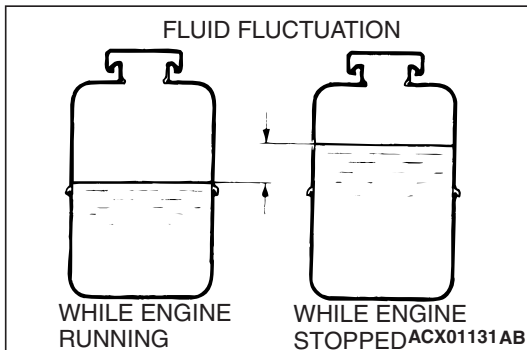
**Q: Is the check result OK?****YES** : Go to Step 2.**NO** : Bleed the air (Refer to [P.37-22](#)). And then go to Step 4 .**STEP 2. Check each hose for crushing or twisting.****Q: Is any hose crushed or twisted?****YES** : Repair or replace the hose. And then go to Step 4.**NO** : Go to Step 3.**STEP 3. Check the steering gear for damage.****Q: Is there damage?****YES** : Repair or replace the part. And then go to Step 4.**NO** : Go to Step 4.**STEP 4. Retest the system.**

Confirm that no noise is generated.

**Q: Is there noise?****YES** : Repeat from Step 1.**NO** : The procedure is complete.

**INSPECTION PROCEDURE 7: Droning Noise**

*NOTE: If a slight "beat noise" is produced by the oil pump when the steering wheel is turned fully and held in that position, this is normal.*

**DIAGNOSIS**

**STEP 1. Check the oil pump or oil pump bracket installation.**

**Q: Is the oil pump or the oil pump bracket installation correct?**

**YES :** Go to Step 2.

**NO :** Repair it. And then go to Step 3.

**STEP 2. Check the oil pump for damage.**

**Q: Is there damage?**

**YES :** Replace the oil pump. And then go to Step 3.

**NO :** Go to Step 3.

**STEP 3. Retest the system.**

Confirm that no noise is generated.

**Q: Is there noise?**

**YES :** Repeat from Step 1.

**NO :** The procedure is complete.

**INSPECTION PROCEDURE 8: Squeaking Noise**

**DIAGNOSIS**

**STEP 1. Check for interference of the wheel and the vehicle body.**

If necessary, adjust the steering angle.

(1) Place the front wheel on a turning radius gauge and measure the steering angle.

**Standard value:**

ITEM	SPECIFICATION
Inner wheel	31° 48' ± 2° 00'
Outer wheel (reference)	27° 06'

(2) If the steering angle is not within the standard value, adjust the toe.

**Standard value: 0 ± 3 mm (0 ± 0.12 inch)**

(3) Adjust the toe by undoing the clip and jam nut, and turning the left and right tie rod turnbuckles by the same amount (in opposite directions).

*NOTE: The toe will move out as the left turnbuckle is turned toward the front of the vehicle and the right turnbuckle is turned toward the rear of the vehicle.*

**Q: Is the steering angle normal?**

**YES :** Go to Step 2.

**NO :** Repeat the toe adjustment. And then go to Step 3.

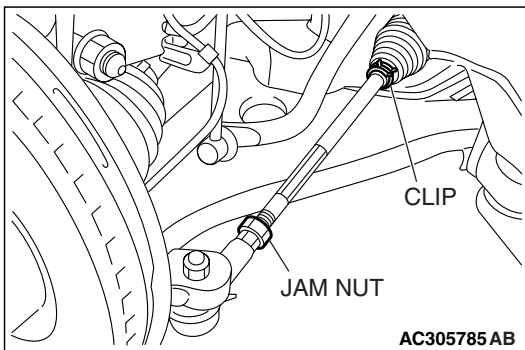
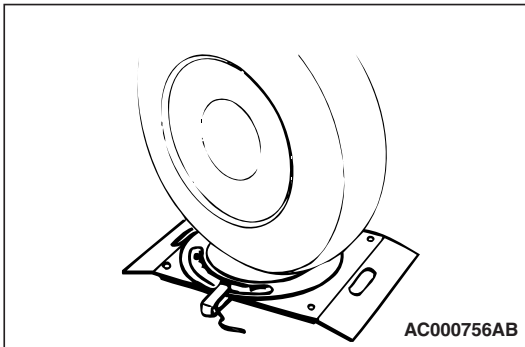

**STEP 2. Check the steering gear for damage.**

**Q: Is there damage?**

**YES :** Repair or replace the part. And then go to Step 3.

**NO :** Go to Step 3.

**STEP 3. Retest the system.**

Confirm that no noise is generated.

**Q: Is there noise?**

**YES** : Repeat from Step 1.

**NO** : The procedure is complete.

**INSPECTION PROCEDURE 9: Vibration**

*NOTE: A slight vibration may be felt when the stationary steering effort is made due to the condition of the road surface. To check whether the vibration actually exists or not, test-drive the vehicle on a dry concrete or asphalt surface. A very slight amount of vibration is not a malfunction.*

**DIAGNOSIS****STEP1. Check the tires for out-of-balance.****Q: Is the check result OK?**

**YES** : Go to Step 2.

**NO** : Balance the tires (Refer to GROUP 31, Wheel and Tire Diagnosis –Wheel Balance Accuracy [P.31-3](#)). Then go to Step 4.

**STEP 2. Check the fluid level.**

- (1) Park the vehicle on a flat, level surface, and then start the engine.
- (2) Turn the steering wheel several times to raise the temperature of the fluid to approximately 50 –60° C (122 – 140° F).
- (3) With the engine running, turn the wheel all the way to the left and right several times.
- (4) Check the fluid in the oil reservoir for foaming or milkiness. Check the difference of the fluid level when the engine is stopped, and while it is running. If the fluid contains air or has milky appearance, or the fluid level fluctuate by 5 mm (0.2 inch) or more, power steering system air bleeding should be done.

**Q: Is the check result OK?**

**YES** : Go to Step 3.

**NO** : Bleed the air (Refer to [P.37-22](#)). Then go to Step 4 .

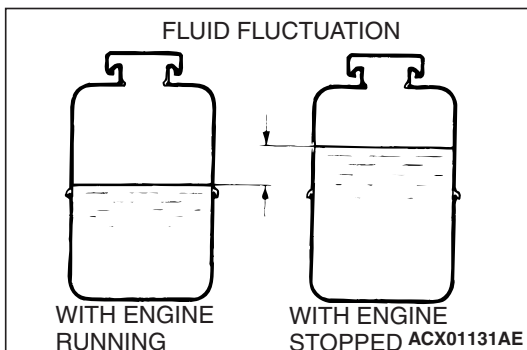
**STEP 3. Check the steering gear for damage.****Q: Is there damage?**

**YES** : Repair or replace the part. Then go to Step 4.

**NO** : Go to Step 4.

---

**STEP 4. Retest the system.**

Confirm that there is no steering wheel vibration.

**Q: Is there vibration?**

**YES :** Repeat from Step 1.

**NO :** The procedure is complete.

---

**INSPECTION PROCEDURE 10: Oil Leakage from Hose Connection**

---

**DIAGNOSIS**

---

**STEP 1. Check for loosening of the pressure/return tube flare nut.**

**Q: Is the flare nut loose?**

**YES :** Tighten it to  $15 \pm 3$  N·m ( $11 \pm 2$  ft-lb) or  $34 \pm 5$  N·m ( $25 \pm 4$  ft-lb). And then go to Step 3.

**NO :** Go to Step 2.

---

**STEP 2. Check the hose connection and the clamp installation.**

Refer to [P.37-59](#).

**Q: Are they correct?**

**YES :** Go to Step 3.

**NO :** Correct hose connection and/or clamp installation. Then go to Step 3.

---

**STEP 3. Retest the system.**

Check that no oil is leaking.

**Q: Is there oil leakage?**

**YES :** Repeat from Step 1.

**NO :** The procedure is complete.

---

**INSPECTION PROCEDURE 11: Oil Leakage from Hose Assembly**

---

**DIAGNOSIS**

---

**STEP 1. Check the hose for damage or clogging.**

**Q: Is the hose damaged or clogged?**

**YES :** Repair or replace it. And then go to Step 2.

**NO :** Go to Step 2.

---

**STEP 2. Retest the system.**

Check that no oil is leaking.

**Q: Is there oil leakage?**

**YES :** Repeat from Step 1.

**NO :** The procedure is complete.

---

**INSPECTION PROCEDURE 12: Oil Leakage from Oil Reservoir**

---

**DIAGNOSIS**

---

**STEP 1. Check the oil reservoir for damage.**

**Q: Is there damage?**

**YES :** Repair or replace it. And then go to Step 3.

**NO :** Go to Step 2.

---

**STEP 2. Check for overflowing.**

**Q: Is there oil overflowing from the reservoir?**

**YES :** Adjust fluid level. And then go to Step 3.

**NO :** Go to Step 3.

---

**STEP 3. Retest the system.**

**Q: Is there oil leakage?**

**YES :** Repeat from Step 1.

**NO :** The procedure is complete.

**INSPECTION PROCEDURE 13: Oil Leakage from Oil Pump**

---

**DIAGNOSIS****STEP 1. Check the oil pump body for damage.****Q: Is there damage?****YES :** Replace the part. Then go to Step 3.**NO :** Go to Step 2.**STEP 2. Check the O-ring or oil seal for damage.****Q: Is there damage?****YES :** Replace the part. Then go to Step 3.**NO :** Go to Step 3.**STEP 3. Retest the system.**

Check that no oil is leaking.

**Q: Is there oil leakage?****YES :** Repeat from Step 1.**NO :** The procedure is complete.

---

**INSPECTION PROCEDURE 14: Oil Leakage from Steering Gear**

---

**DIAGNOSIS****STEP 1. Check the steering gear housing for damage.****Q: Is there damage?****YES :** Replace the part. And then go to Step 2.**NO :** Go to Step 2.**STEP 2. Retest the system.**

Check that no oil is leaking.

**Q: Is there oil leakage?****YES :** Repeat from Step 1.**NO :** The procedure is complete.



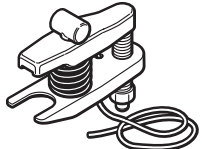
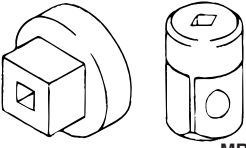
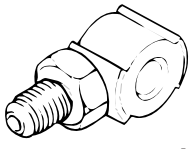
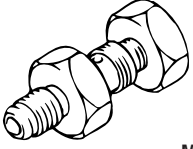
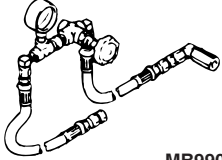
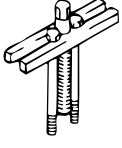
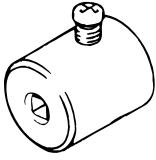

**SPECIAL TOOLS**

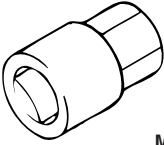
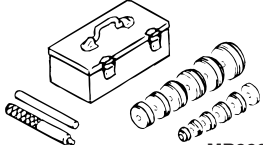
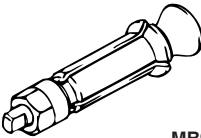
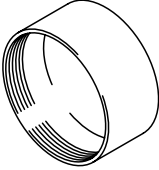
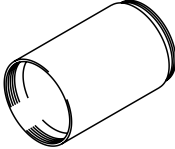
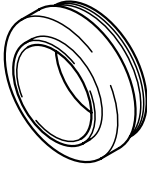
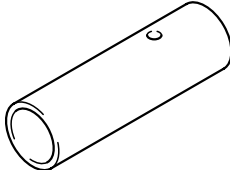
M1372000600387

TOOL	TOOL NUMBER AND NAME	SUPERSESSON	APPLICATION
 <p>AC106827</p>	<p>MB991897 Ball joint remover</p>	<p>MB991113-01, MB990635-01 or General service tool</p>	<p>Knuckle and tie rod end ball joint disconnection <i>NOTE: Steering linkage puller (MB990635 or MB991113) is also available to disconnect knuckle and tie rod end ball joint.</i></p>
 <p>MB990326</p>	<p>MB990326 Preload socket</p>	<p>General service tool</p>	<p>Tie rod end ball joint breakaway torque check</p>
 <p>MB991548</p>	<p>MB991548 Power steering oil pressure gauge adapter (Pump side)</p>	<p>MB991548-01</p>	<p>Oil pump pressure test</p>
 <p>MB991549</p>	<p>MB991549 Power steering oil pressure gauge adapter (Hose side)</p>	<p>MB991549-01</p>	
 <p>MB990662</p>	<p>MB990662 Power steering oil pressure gauge</p>	<p>MB990662-01</p>	
 <p>MB990803</p>	<p>MB990803 Steering wheel puller</p>	<p>-</p>	<p>Steering wheel removal</p>
 <p>MB991006</p>	<p>MB991006 Preload socket</p>	<p>MB990228-01</p>	<p>Steering gear total pinion torque check</p>

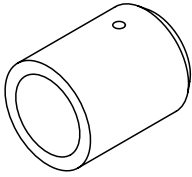
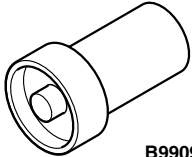
TOOL	TOOL NUMBER AND NAME	SUPERSESSION	APPLICATION
 <p>MB991204</p>	<p>MB991204 Torque wrench socket</p>	<p>General service tool</p>	<ul style="list-style-type: none"> <li>• Rack support adjustment</li> <li>• Rack support cover removal</li> </ul>
 <p>MB990925</p>	<p>MB990925 Bearing and oil seal installer set</p>	<p>MB990925-01 or general service tool</p>	<ul style="list-style-type: none"> <li>• Oil seal and bearing installation</li> <li>• MB990927, MB990938, MB990939 (For details, refer to GROUP 26, Special Tools P.26-5.)</li> </ul>
 <p>MB991120</p>	<p>MB991120 Needle bearing puller</p>	<p>Tool not available</p>	<p>Needle roller bearing removal</p>
	<p>MD998812 Installer cap</p>	<p>-</p>	<p>Gear housing mounting bushing removal</p>
	<p>MD998813 Installer 100</p>	<p>-</p>	
	<p>MD998822 Installer adapter</p>	<p>-</p>	
	<p>MD998368 Bearing installer</p>	<p>-</p>	

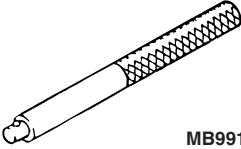

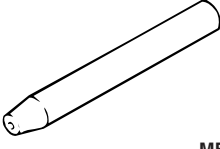
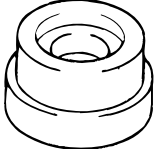
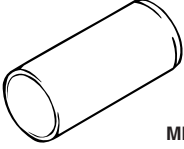
TOOL	TOOL NUMBER AND NAME	SUPERSESSION	APPLICATION
	MD999569 Camshaft oil seal installer	-	Gear housing mounting bushing installation
 <p>B990996</p>	MB990996 Lower arm bushing arbor	-	
 <p>MB991199</p>	MB991199 Oil seal installer	General service tool	Oil seal installation
 <p>MB991197</p>	MB991197 Bar (long type)	General service tool	
 <p>MB991202</p>	MB991202 Oil seal and bearing installer	General service tool	Needle roller bearing and ball bearing installation
 <p>MB991212</p>	MB991213 Rack installer	General service tool	Rack installation
 <p>MB991203</p>	MB991203 Oil seal and bearing installer	Tool not available	Oil seal and bearing installation
 <p>MB991317</p>	MB991317 Seal ring installer	Tool not available	Seal ring installation

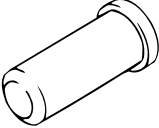
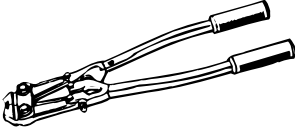
TOOL	TOOL NUMBER AND NAME	SUPERSESSION	APPLICATION
 MB991152	MB991152 Dust cover installer	General service tool	Oil seal installation
 MB991561	MB991561 Boot band crimping tool	MB991561	Bellows band installation

## ON-VEHICLE SERVICE

### STEERING WHEEL FREE PLAY CHECK

M1372001000344

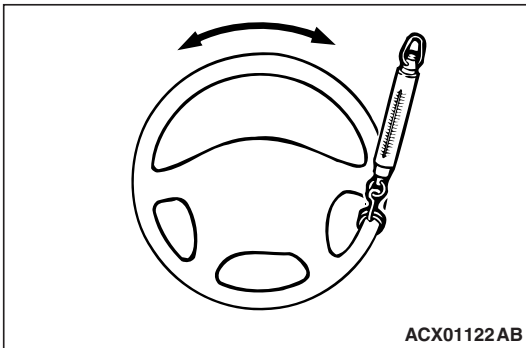

1. With the engine running (hydraulic operation), set the front wheels straight ahead.
2. Slightly move the steering wheel in both directions and measure the play on the steering wheel circumference before the wheels start to move.

**Limit: 30 mm (1.2 inch)**

3. If the play exceeds the limit, check on the steering shaft and steering linkage connection. Correct or replace.
4. If the free play still exceeds the limit value, set the steering wheel straight ahead with the engine stopped. Apply 5 N (1.1 pound) towards the steering wheel circumference and check the play.

**Standard value (steering wheel play with the engine stopped): 10 mm (0.4 inch) or less**

5. If the play exceeds the standard value, remove the steering gear (refer to P.37-34) and check the total pinion torque (refer to P.37-42).

### STEERING ANGLE CHECK

M1372001100608

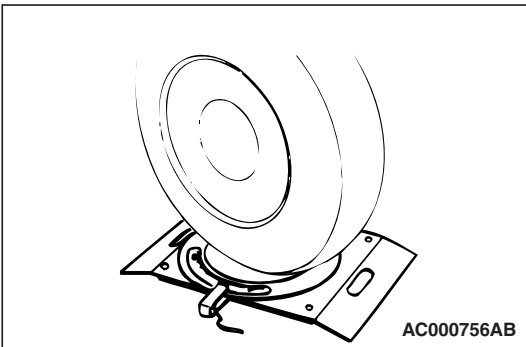

1. Place the front wheel on a turning radius gauge and measure the steering angle.

**Standard value:**

ITEM	SPECIFICATION
Inner wheel	31° 48' ± 2° 00'
Outer wheel (reference)	27° 06'

2. If the steering angle is not within the standard value, adjust the toe as follows.

**Standard value: 0 ± 3 mm (0 ± 0.12 inch)**

- (1) Loosen the jam nut, and unclip the bellows.
- (2) Adjust the toe by turning the left and right tie rod turnbuckles by the same amount (in opposite directions).

*NOTE: The toe will move out as the left turnbuckle is turned toward the front of the vehicle and the right turnbuckle is turned toward the rear of the vehicle.*

- (3) Tighten the jam nut to the specified torque, and tighten the bellows by the clip.

**Tightening torque: 52 ± 2 N·m (38 ± 2 ft-lb)**

3. Recheck the steering angle.

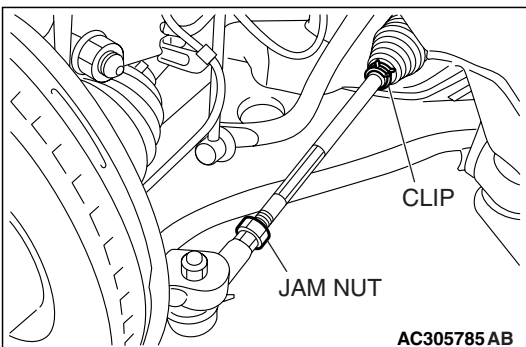

### TIE ROD END BALL JOINT BREAKAWAY TORQUE CHECK

M1372001500510

**Required Special Tools:**

- MB990326: Preload Socket
- MB991897: Ball Joint Remover

**⚠ CAUTION**

- Do not remove the nut from ball joint. Loosen it and use special tool MB991897 to avoid possible damage to the ball joint threads.
- Hang special tool MB991897 with a cord to prevent it from falling.

1. Install special tool MB991897 as shown in the figure.

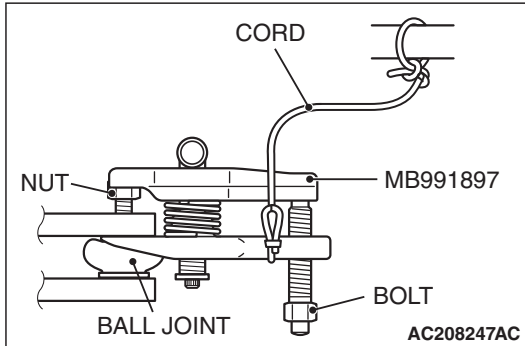

2. Turn the bolt and knob as necessary to make the jaws of special tool MB991897 parallel, tighten the bolt by hand and confirm that the jaws are still parallel.

*NOTE: When adjusting the jaws in parallel, make sure the knob is in the position shown in the figure.*

3. Tighten the bolt with a wrench to disconnect the tie rod end.

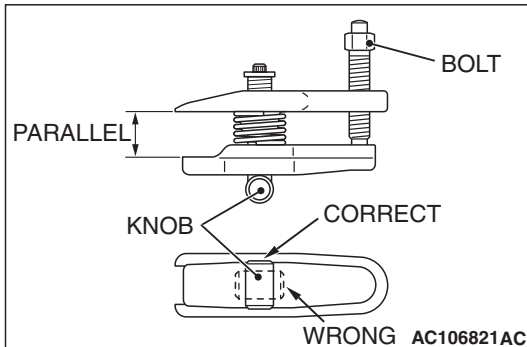

4. Move the ball joint stud several times and install the nut on the stud. Using special tool MB990326, measure the ball joint breakaway torque.

**Standard value: 0.5 – 3.5 N·m (4.4 – 31.0 in-lb)**

5. If the breakaway torque exceeds the standard value, replace the tie rod end assembly.
6. If the breakaway torque is under the standard value, check the ball joint for end play or ratcheting. If there is no end play or ratcheting, the ball joint can be re-used.

**⚠ CAUTION**

**Always use a new ball joint nut, as it is a self-locking nut.**

7. Install the tie rod end to the knuckle, then tighten a new self-locking nut to the specified torque.

**Tightening torque: 29 ± 4 N·m (21 ± 3 ft-lb)**

**STATIONARY STEERING EFFORT CHECK**

M1372001700558

1. With the vehicle stopped on a flat and paved surface, turn the steering wheel to the straight ahead position.
2. Start the engine and allow to idle.

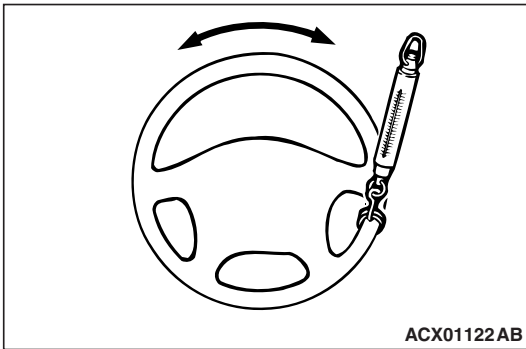

3. Attach a spring scale to the outer circumference of the steering wheel and measure the steering force required to turn the steering wheel from the straight ahead position to the left and right (within a range of 1.5 turns). Also check to be sure that there is no significant change in the required steering effort.

**Standard value:**

**Steering effort: 35 N (7.9 lb) or less**

**Fluctuation allowance: 5.9 N (1.33 lb) or less**

4. If the measured value exceeds the standard value, refer to Inspection Procedure 2 "Difficult Steering Wheel Operation (Insufficient Power Assist)" P.37-7.

### STEERING WHEEL RETURN TO CENTER CHECK

M1372001800339

Conduct a road test:

1. Make both gradual and sudden turns and check the steering wheel return.
2. At a vehicle speed of approximately 35 km/h (22 mph), turn the steering wheel 90 degrees, hold a few seconds, then release. If the steering wheel then returns 70 degrees or more, the return can be judged as satisfactory.

*NOTE: There will be a momentary feeling or "heaviness" when the wheel is turned quickly, but this is not abnormal. (Oil pump discharge amount is especially apt to be insufficient during idling.)*

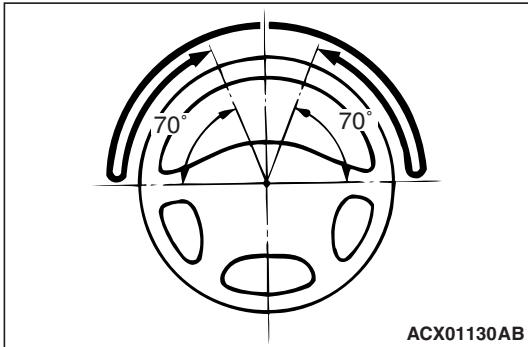

### DRIVE BELT TENSION CHECK

M1372001900284

Refer to GROUP 00, Maintenance Service –Drive Belts P.00-52.

### FLUID LEVEL CHECK

M1372002000303

1. Park the vehicle on a flat, level surface.
2. Start the engine, and then turn the steering wheel several times to raise the temperature of the fluid to approximately 50 –60° C (122 –140° F).
3. With the engine running, turn the wheel all the way to the left and right several times.
4. Check the fluid in the oil reservoir for foaming or milkiness. Check the difference of the fluid level when the engine is stopped, and while it is running. If the fluid contains air or has milky appearance, or the fluid level fluctuate by 5 mm (0.2 inch) or more, power steering system air bleeding should be done.

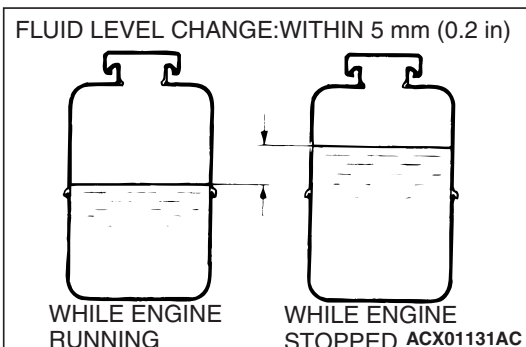

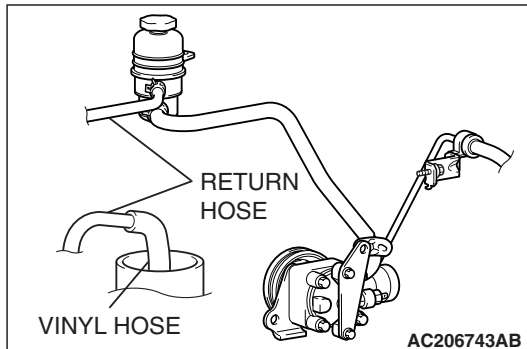

M1372002100366

## FLUID REPLACEMENT

1. Raise and support the front wheels.
2. Disconnect the return hose connection, and then connect a vinyl hose to the return hose, and drain the fluid into a container.
3. Disconnect the ignition coil connectors (refer to GROUP 16, Ignition Coil [P.16-42](#) <2.4L ENGINE>, [P.16-43](#) <3.8L ENGINE>).
4. While operating the starter motor intermittently, turn the steering wheel all the way to the left and right several times to drain all of the fluid.
5. Connect the return hose securely, and then secure with the clip.
6. Fill the oil reservoir with GENUINE MITSUBISHI POWER STEERING FLUID up to the lower mark of the reservoir, and then bleed the air.

## POWER STEERING SYSTEM AIR BLEEDING

M1372002200471

Perform air bleeding procedure as necessary after replacing the steering gear, oil pump or the steering fluid lines.

1. Raise and support the front wheels.
2. Disconnect the ignition coil connectors (Refer to GROUP 16, Ignition Coil [P.16-42](#) <2.4L ENGINE>, [P.16-43](#) <3.8L ENGINE>).

### **⚠ CAUTION**

**Perform air bleeding only while cranking the engine. Do not perform air bleeding while the engine is running. If you do so, air in the fluid will be increased and air bleeding will become more difficult. During air bleeding, refill the steering fluid so that the level never falls below the lower mark on the dipstick.**

3. Turn the steering wheel all the way to the left and right five or six times while using the starter motor to crank the engine intermittently several times (for 15 to 20 seconds).
4. Connect the ignition coil connectors (Refer to GROUP 16, Ignition Coil [P.16-42](#) <2.4L ENGINE>, [P.16-43](#) <3.8L ENGINE>).
5. Start the engine and allow to idle.
6. Turn the steering wheel to the left and right until there are no air bubbles in the oil reservoir.
7. Confirm that the fluid is not milky, and that the level is between the high and low dipstick marks.
8. Confirm that there is very little change in the fluid level when the steering wheel is turned left and right.

**CAUTION**

If the fluid level rises suddenly after the engine is stopped, the air has not been completely bled. If air bleeding is not complete, there will be abnormal noises from the pump and the flow-control valve, and this condition could reduce the life of the power steering components.

9. Confirm that the change in the fluid level is no more than 5 mm (0.2 inch) when the engine is stopped.

10. If the change of the fluid level is 5 mm (0.2 inch) or more, the air has not been completely bled from the system. The air bleeding procedure must be repeated.

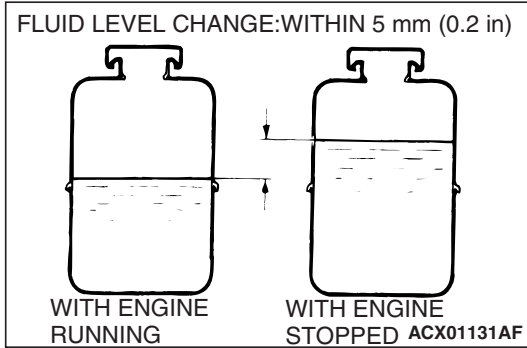

**OIL PUMP PRESSURE TEST**

M1372002300467

**Required Special Tools:**

- MB990662: Power Steering Oil Pressure Gauge
- MB991548: Power Steering Oil Pressure Gauge Adapter (Pump Side)
- MB991549: Power Steering Oil Pressure Gauge Adapter (Hose Side)

1. Disconnect the pressure hose from the oil pump, and then connect special tools MB991548, MB990662 and MB991549.
2. Bleed air, then turn the steering wheel several times while the vehicle is not moving so that the temperature of the fluid rises to approximately 50 –60° C (122 –140° F).
3. Start the engine and idle it.

**CAUTION**

The pressure gauge shut-off valve must not remain closed for more than 10 seconds.

4. Fully close the shut-off valve of the pressure gauge and measure the oil pump relief pressure to confirm that it is within the standard value range. Open it again immediately after checking the pressure.

**Standard value:**

- 2.4L engine: 8.3 –8.8 MPa (1,204 –1,276 psi)
- 3.8L engine: 9.3 –9.8 MPa (1,349 –1,421 psi)

5. If it is not within the standard value, replace the oil pump.
6. Check whether or not the hydraulic pressure is the standard value when no-load conditions are created by fully opening the shut-off valve of the pressure gauge.

**Standard value: 0.8 –1.0 MPa (116 –145 psi)**

7. If it is not within the standard value, the probable cause is a malfunction of the oil line or steering gear, so check these parts and repair as necessary.

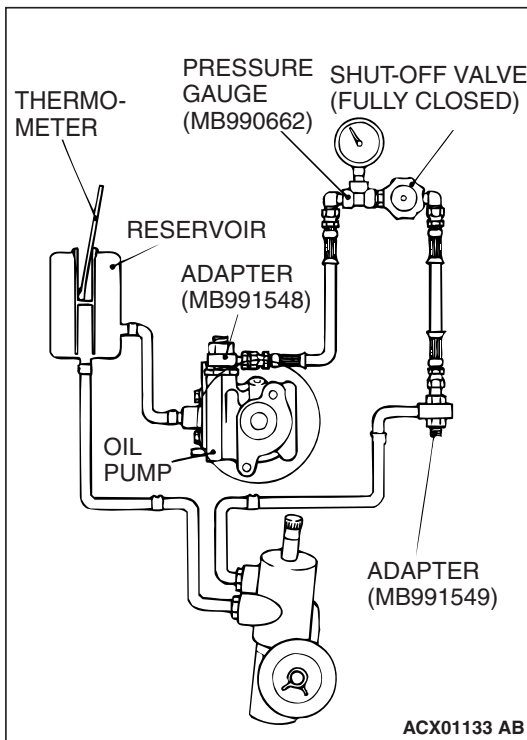

- Turn the steering wheel all the way to the left or right; then check the retention hydraulic pressure.

**Standard value:**

**2.4L engine: 8.3 –8.8 MPa (1,204 –1,276 psi)**

**3.8L engine: 9.3 –9.8 MPa (1,349 –1,421 psi)**

- If not within the standard value, overhaul or replace the steering gear. Remeasure fluid pressure.
- Remove special tools MB991548, MB990662 and MB991549, connect the pressure hose to the oil pump, and then tighten the eye bolt to the specified torque.

**Tightening torque: 57 ± 7 N· m (42 ± 5 ft-lb)**

- Bleed the system (Refer to P.37-22).

## POWER STEERING PRESSURE SWITCH CHECK

M1372007200443

### Required Special Tools:

- MB990662: Power Steering Oil Pressure Gauge
- MB991548: Power Steering Oil Pressure Gauge Adapter (Pump Side)
- MB991549: Power Steering Oil Pressure Gauge Adapter (Hose Side)

- Disconnect the pressure hose from the oil pump, and then connect the special tools MB991548, MB990662 and MB991549.
- Bleed air, and then turn the steering wheel several times while the vehicle is not moving so that the temperature of the fluid rises to approximately 50 –60° C (122 –140° F).
- The engine should be idling.
- Disconnect the connector for the oil pressure switch, and place an ohmmeter at the switch.
- Gradually close the shut-off valve of the pressure gauge and increase the hydraulic pressure, then check whether or not the hydraulic pressure that activates the switch is within the standard value.

**Standard value: 1.8 –2.4 MPa (261 –348 psi)**

- Gradually open the shut-off valve and reduce the hydraulic pressure; then check whether or not the hydraulic pressure that deactivates the switch is within the standard value.

**Standard value: 0.8 –1.4 MPa (116 –203 psi)**

- Remove special tools MB991548, MB990662 and MB991549, connect the pressure hose to the oil pump, and then tighten the eye bolt to the specified torque.

**Tightening torque: 57 ± 7 N· m (42 ± 5 ft-lb)**

- Bleed the system. (Refer to P.37-22).

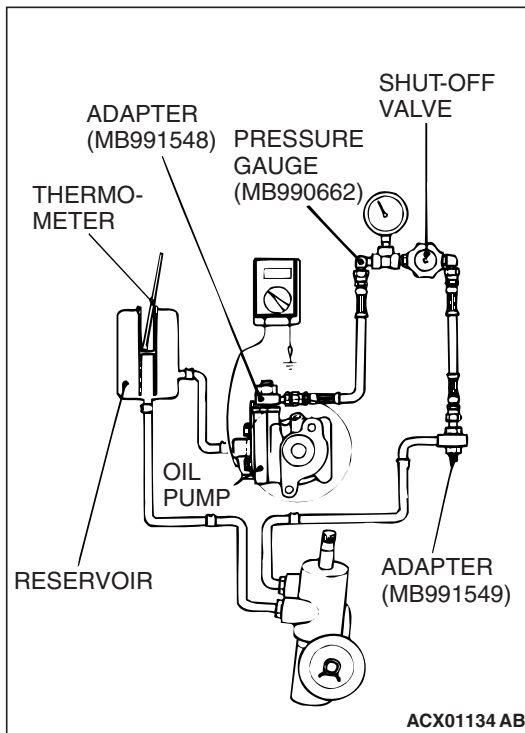



## TIE ROD END BALL JOINT DUST COVER CHECK

M1372008600400

1. Press the dust cover with your finger to check whether the dust cover is cracked or damaged.
2. If the dust cover is cracked or damaged, replace the tie rod end.

*NOTE: If the dust cover is cracked or damaged, the ball joint may be damaged.*

STEERING COLUMN SHAFT ASSEMBLY SHOCK  
ABSORBING MECHANISM CHECK

M1372013500302

- If a collision occurs or severe impact is applied to the steering wheel, the collision energy absorbing mechanism (slide plate, ripping plate, tilt pin) may have operated. Once the mechanism has operated, it will be inoperative even if there is no apparent damage. Determine if the steering column shaft can be reused by the following procedure. If the collision energy absorbing mechanism has already operated, replace the steering column assembly.
- If any excessive radial or axial free play on the steering wheel is found with the tilt lever in the lock position, always check the steering column assembly.

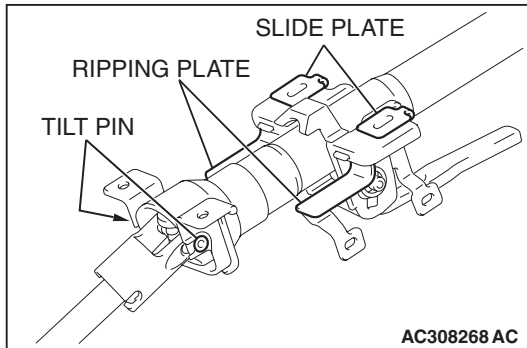
**⚠ WARNING**

- ***If the vehicle continues to be driven after the collision absorbing mechanism has operated, the steering column shaft may be damaged while driving.***
- ***If there is a slack in the slide plate, do not attempt to repair it. Replace the steering column assembly.***

## Inspection Procedure

1. Remove the steering column covers (lower and upper).

**⚠ CAUTION**

**Do not release the tilt lever until the steering column has been installed.**

2. Place the tilt lever in the locked position.
3. Loosen the two upper steering column mounting bolts by two turns.
4. Hold the steering wheel, and then try to rock it. If there is a radial or axial free play, replace the steering column assembly.

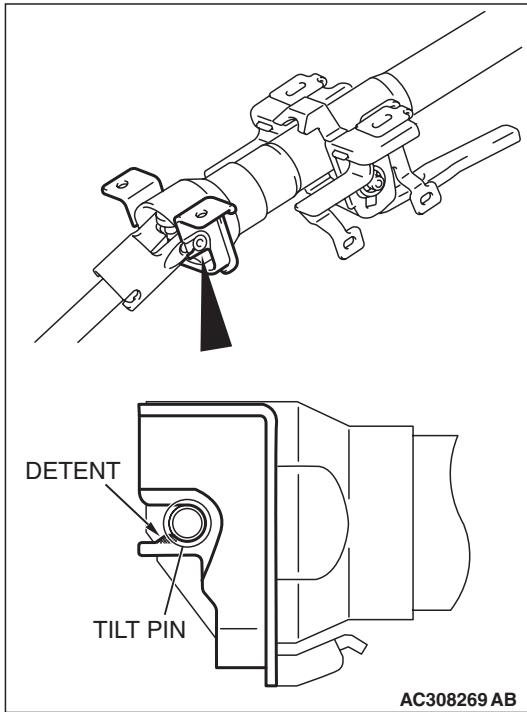

5. Check the tilt pin fixing detent of the lower bracket for deformation. If there is a deformation, replace the steering column assembly.

**⚠ CAUTION**

- Be careful that nothing is pinched between the slide plate and the body.
  - Do not release the tilt lever until the steering column has been installed.
6. If no problem is found during the inspection, tighten the steering column assembly mounting bolts to the specified torque.

**Tightening torque:  $12 \pm 2$  N·m ( $102 \pm 22$  in-lb)**

# STEERING WHEEL

## REMOVAL AND INSTALLATION

M1372011400495

### **WARNING**

- Before removing the steering wheel and air bag module assembly, refer to **GROUP 52B, Service Precautions (P.52B-26)** and **Air Bag Module and Clock Spring (P.52B-408)**.
- When removing and installing the steering wheel, do not let it bump against the air bag module.

#### Post-installation Operation

- Checking Steering Wheel Position with Wheels Straight Ahead

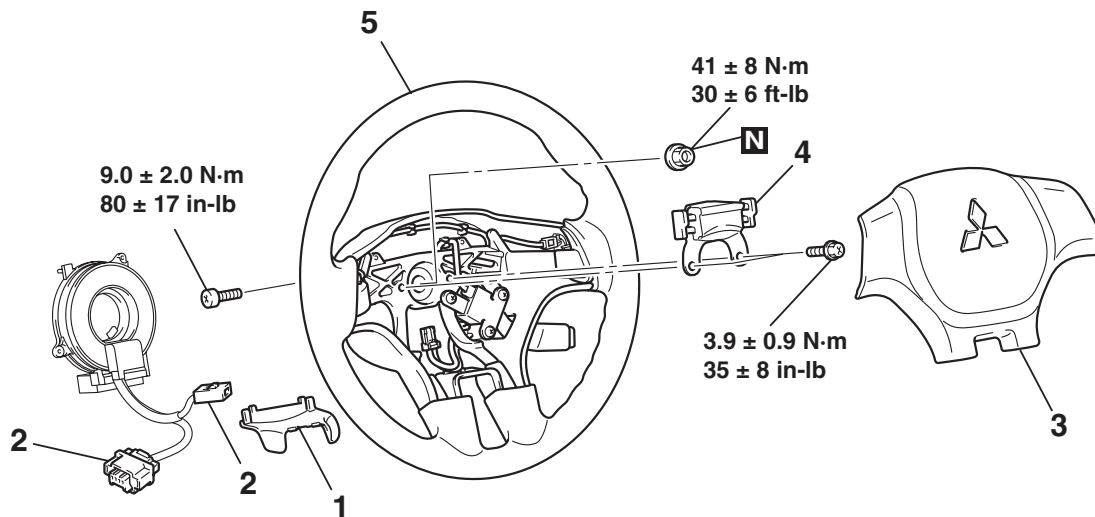

AC405745AB

#### REMOVAL STEPS

- <<A>>
1. STEERING WHEEL LOWER COVER
  2. CONNECTORS (FOR HORN, AIR BAG MODULE, AND STEERING WHEEL REMOTE CONTROL HARNESS)
  3. AIR BAG MODULE
  4. STEERING WHEEL DYNAMIC DAMPER

<<B>>

5. STEERING WHEEL ASSEMBLY

#### INSTALLATION STEPS

4. STEERING WHEEL DYNAMIC DAMPER <3.8L ENGINE>
3. AIR BAG MODULE
2. CONNECTORS (FOR HORN, AIR BAG MODULE, AND STEERING WHEEL REMOTE CONTROL HARNESS)
1. STEERING WHEEL LOWER COVER

**NOTE:** For air bag module removal, refer to **GROUP 52B, Air Bag Module and Clock Spring P.52B-408**.

#### Required Special Tool:

- MB990803: Steering Wheel Puller

## REMOVAL SERVICE POINTS

<<A>> CONNECTOR (FOR AIR BAG MODULE)  
REMOVAL

Slide the outer housing of the clock spring connector in the arrow direction shown, and disconnect the connector.

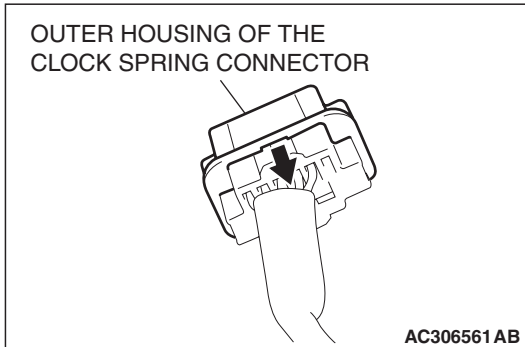

## &lt;&lt;B&gt;&gt;STEERING WHEEL ASSEMBLY REMOVAL

**⚠ CAUTION**

Use the special tool to remove the steering wheel since the steering column collision absorbing mechanism may be damaged.

Use special tool MB990803 to remove the steering wheel.

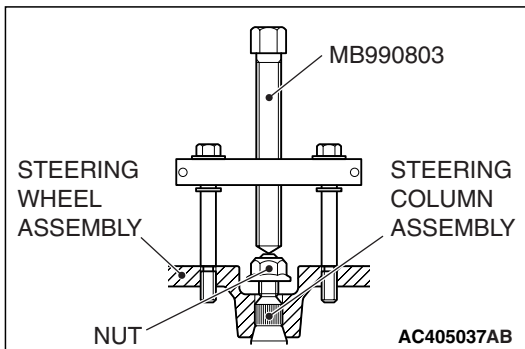

# STEERING SHAFT

## REMOVAL AND INSTALLATION

M1372011500458

**⚠ WARNING**

Before removing the air bag module and steering wheel assembly, refer to **GROUP 52B, Service Precautions (P.52B-26)** and **Air Bag Module and Clock Spring (P.52B-408)**.

**Pre-removal Operation**

- Air bag Module and Steering Wheel Assembly Removal (Refer to P.37-27).
- Instrument Panel Lower Panel Removal (Refer to GROUP 52A, Instrument Panel P.52A-21).

**Post-installation Operation**

- Instrument Panel Lower Panel Installation (Refer to GROUP 52A, Instrument Panel P.52A-21).
- Air bag Module and Steering Wheel Assembly Installation (Refer to P.37-27).

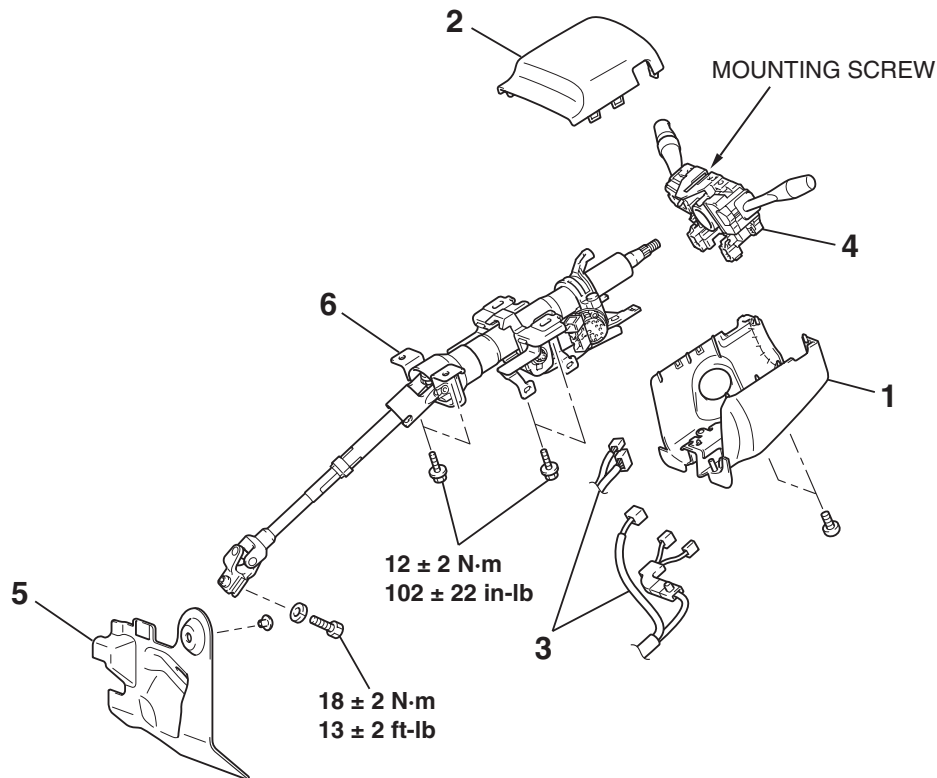

AC405754AB

**REMOVAL STEPS**

1. STEERING COLUMN LOWER COVER
2. STEERING COLUMN UPPER COVER
3. CONNECTORS' CONNECTION FOR ENGINE STARTING SWITCH ASSEMBLY AND COLUMN SWITCH ASSEMBLY

**REMOVAL STEPS (Continued)**

4. CLOCK SPRING AND COLUMN SWITCH ASSEMBLY (REFER TO GROUP 52B, AIR BAG MODULE AND CLOCK SPRING P.52B-408).
  - KEY INTERLOCK CABLE CONNECTION (REFER TO GROUP 23A, A/T KEY INTERLOCK AND SHIFT LOCK MECHANISM P.23A-398).
5. STEERING SHAFT PAD
6. STEERING COLUMN ASSEMBLY

<<A>> >>A<<

## REMOVAL SERVICE POINT

<<A>> STEERING COLUMN ASSEMBLY  
REMOVAL**⚠ CAUTION**

The tilt lever should be held in the lock position until the steering column assembly is installed to the vehicle. If the steering column assembly is removed with the tilt lever released, or the tilt lever is released after the steering column assembly was removed from the vehicle, the steering column assembly cannot be reinstalled correctly. If the steering column assembly is installed incorrectly, the collision energy absorbing mechanism may be damaged.

1. Ensure that the tilt lever is in the lock position, and remove the steering column assembly mounting bolts.
2. Pinch the steering column shaft clip with pliers, and pull up the shaft in the direction shown to disengage the steering column assembly.

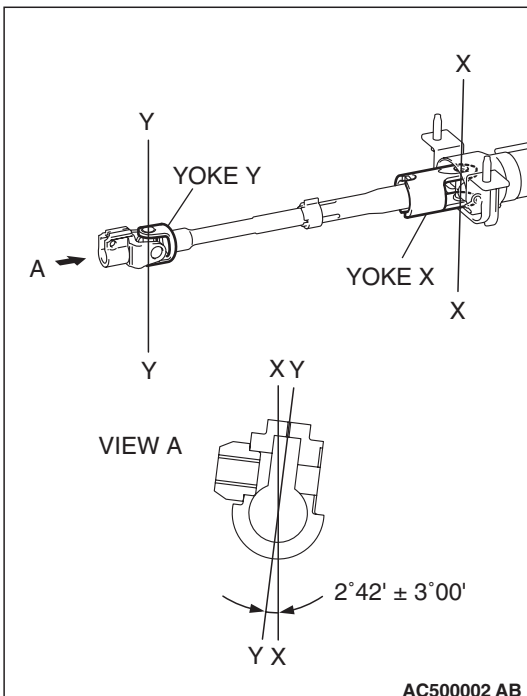
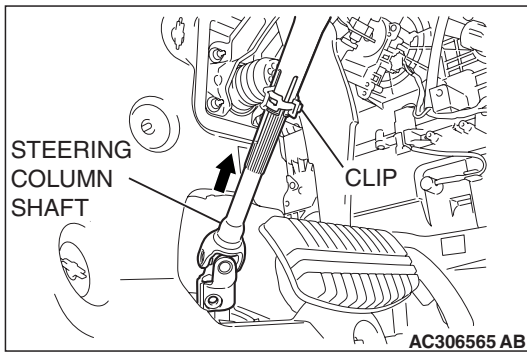

*NOTE: If the steering column shaft is removed accidentally, remove the steering column assembly and be sure to insert the steering column shaft into the steering column as shown in the figure.*

## INSTALLATION SERVICE POINT

## &gt;&gt;A&lt;&lt; STEERING COLUMN ASSEMBLY INSTALLATION

**⚠ CAUTION**

- If reusing the steering column assembly, do not release the tilt lever until the steering column assembly has been installed.
- If a new steering column assembly is being installed, do not release the tilt lever until it has been installed. Do not remove the tilt lever fixing band until the installation is completed.
- When installing the steering column assembly, do not leave it fixed temporarily at only one point. Be sure the steering column assembly is not shaken strongly. If this happens, the collision absorbing mechanism at the steering column assembly mounting location may be damaged.

Ensure that the tilt lever is in the lock position, and install the steering column assembly. Tighten the four bolts finger-tight in the order shown, and then tighten them to the specified torque in the order shown.

**Tightening torque:  $12 \pm 2$  N·m ( $102 \pm 22$  in-lb)**

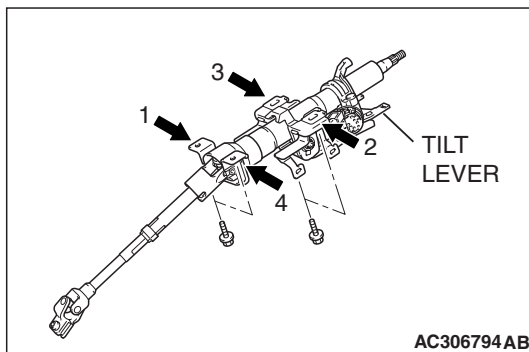

DISASSEMBLY AND ASSEMBLY

M1372011700214

**⚠ WARNING**

Do not move the tilt lever from the lock position until the installation is completed. If you move it accidentally, the steering column cannot be reinstalled correctly.

**⚠ CAUTION**

When the ignition key cylinder is replaced, register the encrypted code. Refer to GROUP 54A, Encrypted Code Registration Criteria Table P.54A-13.

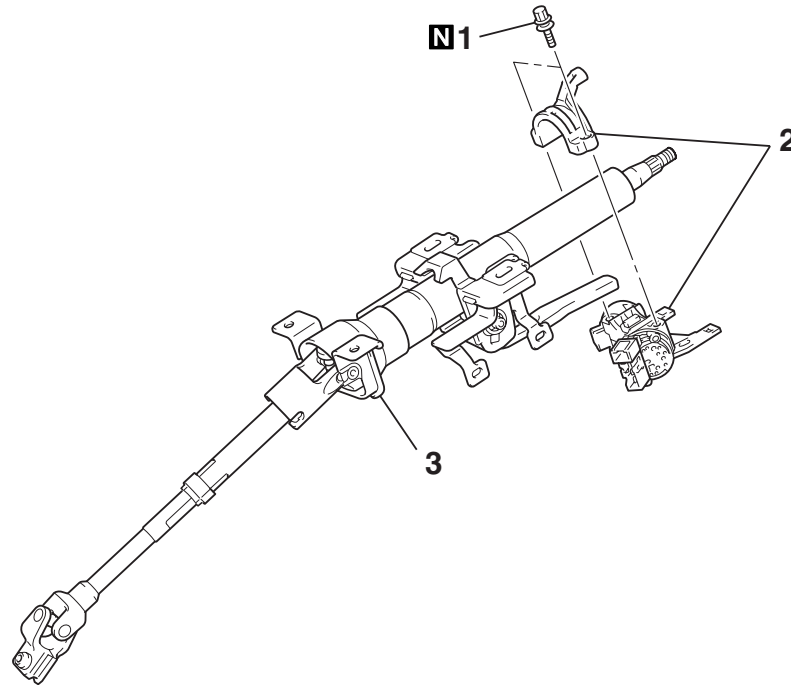

AC306566 AB

<<A>> >>A<< 1. **DISASSEMBLY STEPS**  
STEERING LOCK BOLT

>>A<< 2. **DISASSEMBLY STEPS (Continued)**  
ENGINE STARTING SWITCH  
ASSEMBLY  
3. STEERING COLUMN ASSEMBLY

**DISASSEMBLY SERVICE POINT**

**<<A>> STEERING LOCK BOLT REMOVAL**

1. Drill a hole in the steering lock bolt a hole deep enough for the tap to stand.
2. Remove the steering lock bolt with a left-hand tap.

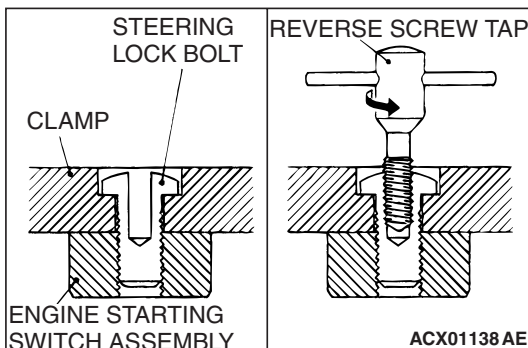



**ASSEMBLY SERVICE POINT**

**>>A<< ENGINE STARTING SWITCH ASSEMBLY/STEERING LOCK BOLT INSTALLATION**

**⚠ CAUTION**

The bolts must be replaced with new ones when the steering lock is installed.

1. When installing the engine starting switch assembly to the steering column assembly, temporarily install the engine starting switch assembly in alignment with the column boss.
2. After checking that the lock works properly, tighten the steering lock bolts until the head is twisted off.

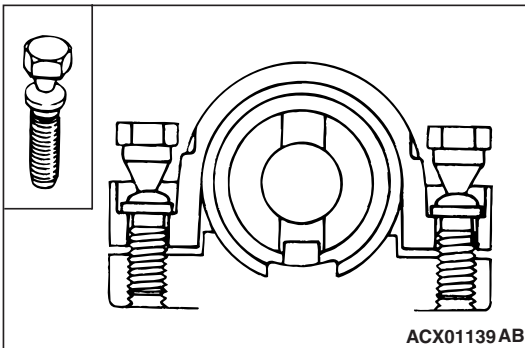

**POWER STEERING GEAR BOX AND LINKAGE****REMOVAL AND INSTALLATION**

M1372010900550

**⚠ WARNING**

- **Before removing the power steering gear assembly, refer to GROUP 52B, Service Precautions (P.52B-26) and Air Bag Module and Clock Spring (P.52B-408).**
- **Center the front wheels. Failure to do so may damage the SRS clock spring and render the SRS system inoperative, risking serious injury.**

**⚠ CAUTION**

\* : Indicates parts which should be temporarily tightened, and then fully tightened after placing the vehicle horizontally and loading the full weight of the engine on the vehicle body.

**Pre-removal Operation**

- Power Steering Fluid Draining (Refer to P.37-22).
- Front Under Cover Removal
- Center member Removal (Refer to GROUP 32, Engine Roll Stopper and Center member P.32-9).
- Lower Arm Assembly Removal (Refer to GROUP 33, Lower Arm P.33-15).
- Air Bag Module and Steering Wheel Assembly Removal (Refer to P.37-27).
- Stabilizer Link and Stabilizer Bar Disconnection (Refer to GROUP 33, Stabilizer Bar P.33-20).

**Post-installation Operation**

- Check the dust cover for cracks or damage by pushing it with your finger.
- Stabilizer Link and Stabilizer Bar Connection (Refer to GROUP 33, Stabilizer Bar P.33-20).
- Steering Wheel Assembly and Air Bag Module Installation (Refer to P.37-27).
- Checking Steering Wheel Position with Wheels Straight Ahead.
- Lower Arm Assembly Installation (Refer to GROUP 33, Lower Arm P.33-15).
- Center member Installation (Refer to GROUP 32, Engine Roll Stopper and Center member P.32-9).
- Front Under Cover Installation
- Front Wheel Alignment Adjustment (Refer to GROUP 33, On-vehicle Service –Front Wheel Alignment Check and Adjustment P.33-6).
- Power Steering Fluid Supplying (Refer to P.37-22).
- Power Steering Fluid Line Bleeding (Refer to P.37-22).

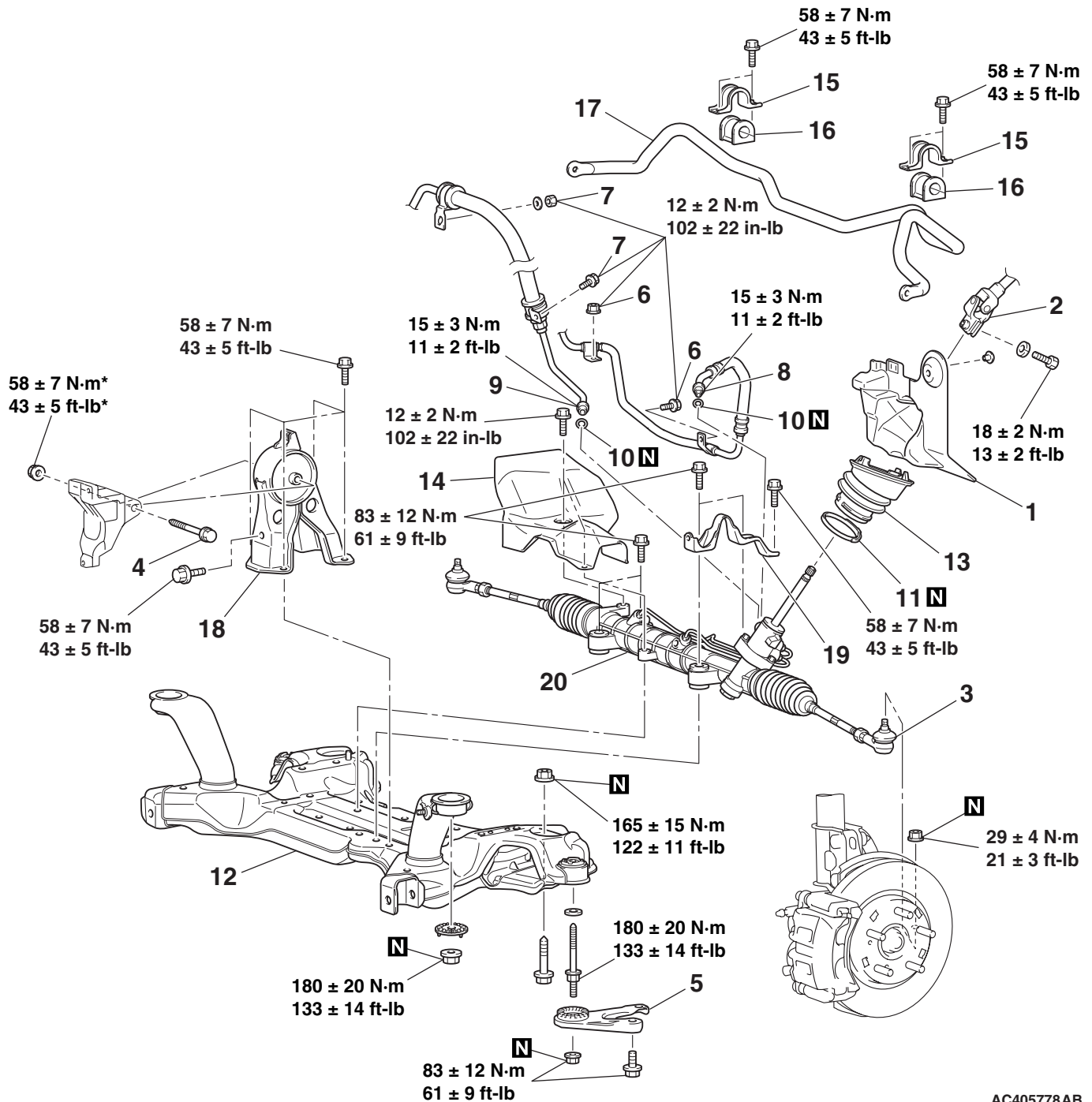

AC405778AB

**REMOVAL STEPS**

- <<A>> 1. STEERING SHAFT PAD
- <<A>> 2. STEERING COLUMN ASSEMBLY AND STEERING GEAR CONNECTION
- <<B>> 3. TIE ROD END AND KNUCKLE CONNECTION
- <<B>> 4. REAR ROLL STOPPER CONNECTING BOLT
- <<C>> >>D<< 5. FRONT AXLE CROSSMEMBER STAY
- 6. RETURN TUBE CLAMP BOLT AND NUT

**REMOVAL STEPS (Continued)**

- 7. PRESSURE TUBE CLAMP BOLT AND NUT
- 8. RETURN TUBE CONNECTION
- 9. PRESSURE HOSE CONNECTION
- 10. O-RING
- >>C<< 11. PINCH CLAMP
- <<D>> >>C<< 12. CROSSMEMBER ASSEMBLY
- >>C<< 13. STEERING COLUMN DASH PANEL COVER
- 14. STEERING GEAR AND LINKAGE PROTECTOR <3.8L ENGINE>
- >>B<< 15. STABILIZER BRACKET
- >>B<< 16. STABILIZER BUSHING

**REMOVAL STEPS (Continued)**

- >>B<< 17. STABILIZER BAR
- >>A<< 18. REAR ROLL STOPPER
- >>A<< 19. POWER STEERING GEAR BRACKET
- 20. POWER STEERING GEAR AND LINKAGE

**Required Special Tool:**

- MB991897: Ball Joint Remover

**REMOVAL SERVICE POINTS****<<A>> STEERING COLUMN ASSEMBLY AND STEERING GEAR DISCONNECTION**

1. Pinch the steering column shaft clip with pliers, and pull up the shaft in the direction shown to disengage the steering column assembly.

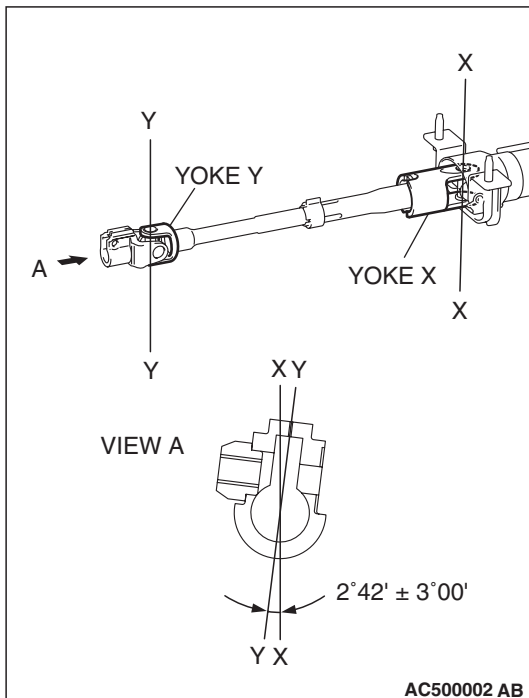
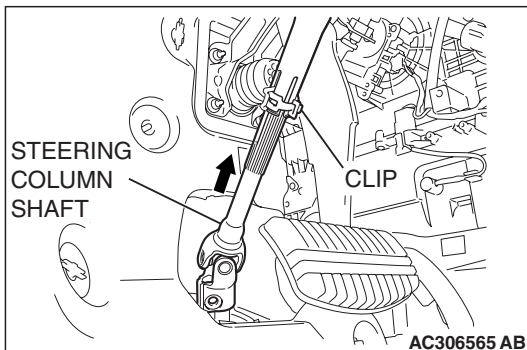

*NOTE: If the steering column shaft is removed accidentally, remove the steering column assembly and be sure to insert the steering column shaft into the steering column as shown in the figure.*

## <<B>> TIE ROD END AND KNUCKLE DISCONNECTION

### ⚠ CAUTION

- Do not remove the nut from ball joint. Loosen it and use special tool MB991897 to avoid possible damage to ball joint threads.
- Hang special tool MB991897 with a cord to prevent it from falling.

1. Install special tool MB991897 as shown in the figure.

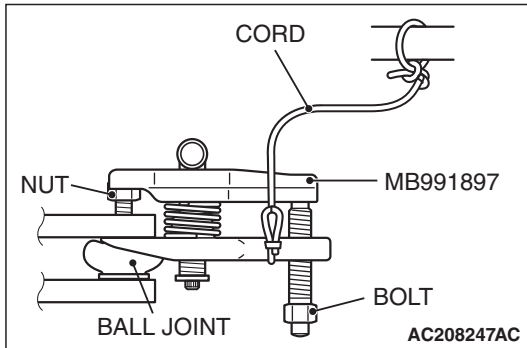

2. Turn the bolt and knob as necessary to make the jaws of special tool MB991897 parallel, tighten the bolt by hand and confirm that the jaws are still parallel.

*NOTE: When adjusting the jaws in parallel, make sure the knob is in the position shown in the figure.*

3. Tighten the bolt with a wrench to disconnect the tie rod end.

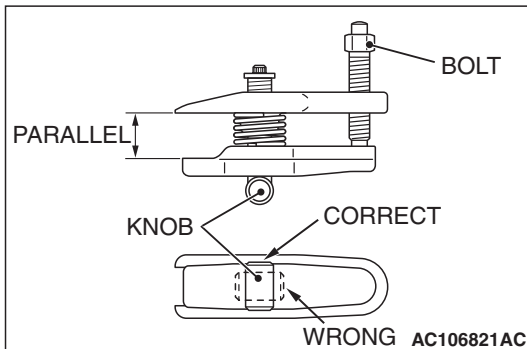

## <<C>> FRONT AXLE CROSSMEMBER STAY REMOVAL

The crossmember mounting bolts need not be unscrewed when the front axle crossmember stay is replaced. However, the bolts may be loose while the front axle crossmember stay is removed. Retighten the bolts to  $180 \pm 20$  N·m ( $133 \pm 14$  ft-lb).

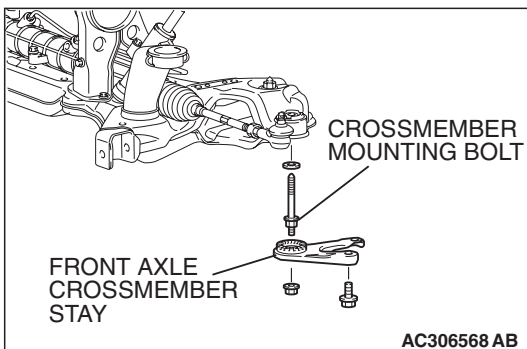

**<<D>> CROSSMEMBER ASSEMBLY REMOVAL**

1. From inside the vehicle, loosen the 3 shown clips from the body panel.

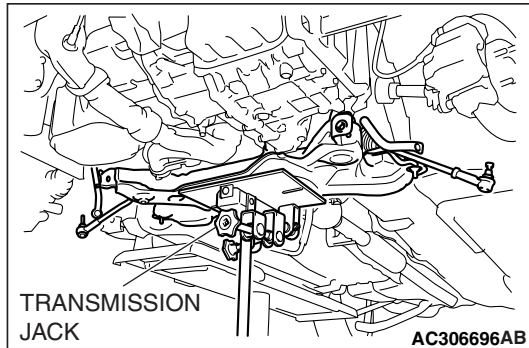
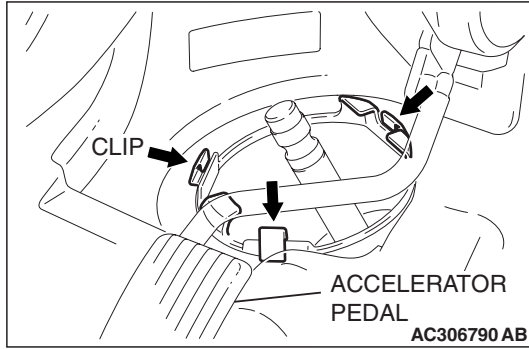

2. Use a transmission jack to hold the crossmember, and then remove the crossmember mounting nuts and bolts.
3. Lower the crossmember with the rear roll stopper, the stabilizer bar and the steering gear.

**INSTALLATION SERVICE POINTS****>>A<< POWER STEERING GEAR BRACKET/REAR ROLL STOPPER INSTALLATION**

Tighten the bolts as follows:

1. Tighten bolt A and then tighten bolt B.
2. Tighten bolts E finger-tight.
3. Tighten bolt C and then tighten bolts D.
4. Tighten bolts E and then tighten bolt F.

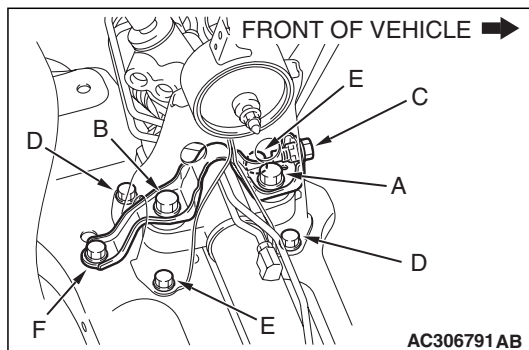
**>>B<< STABILIZER BAR/STABILIZER BUSHING/STABILIZER BRACKET INSTALLATION**

Align the stabilizer bar identification mark with the right end of the bushing (LH).

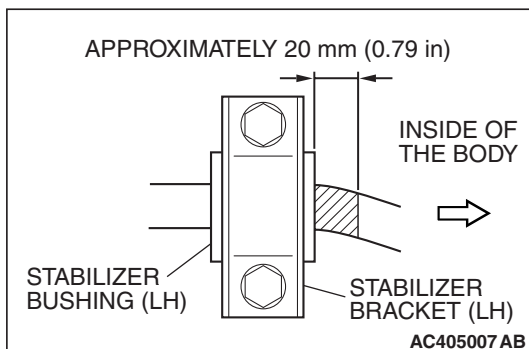

### >>C<< STEERING COLUMN DASH PANEL COVER/CROSSMEMBER ASSEMBLY/PINCH CLAMP INSTALLATION

1. Install the pinch clamp and align the steering column dash panel cover notch (arrow A) with the steering gear lug (arrow B), and then install the steering column dash panel cover to the steering gear.

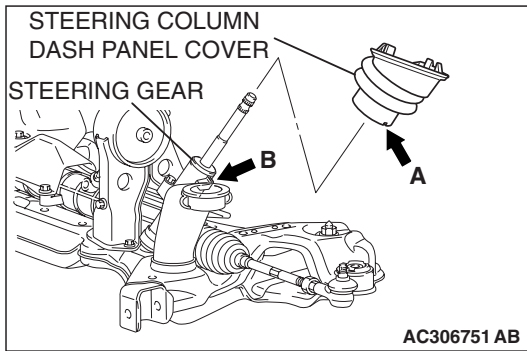

2. Use the end pliers to tighten the pinch clamp. The pinched dimension should be as follows.

**A:  $2.5 \pm 0.5$  mm ( $0.10 \pm 0.02$  inch)**

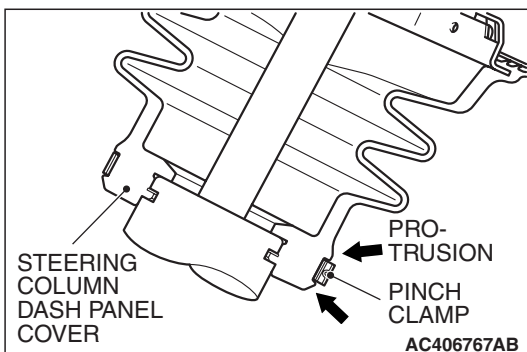
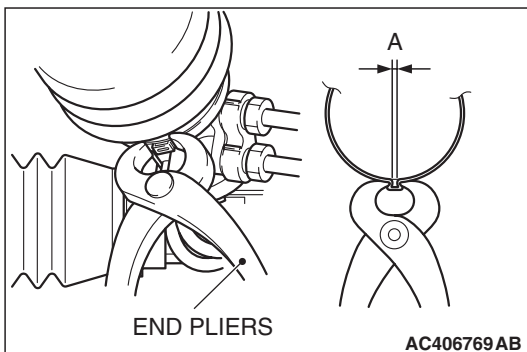

*NOTE: Pinch clamp must be located securely between protrusions of the steering column dash panel cover.*

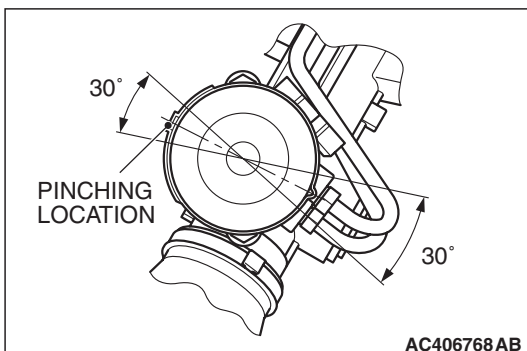

*NOTE: Pinching location must be in the area shown in the illustration.*

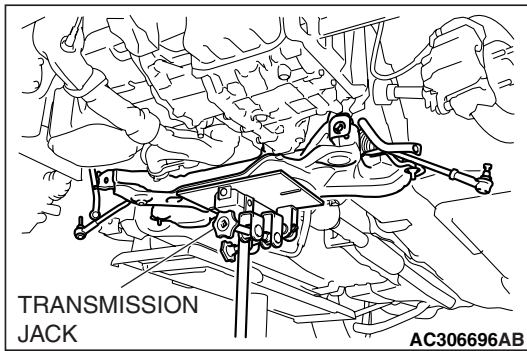

- Use a transmission jack to lift the crossmember assembly.

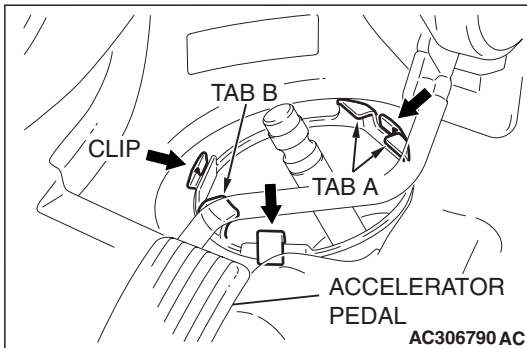

- From inside the vehicle, pull tab A and then tab B to secure the three clips to the body panel.

*NOTE: When securing the steering column dash panel cover to the body panel, be careful that the seal lip does not move backwards.*

- Check that it has been secured by pressing down the tip of the clips by your finger. Also check that the steering column dash panel cover is installed securely to the steering gear.

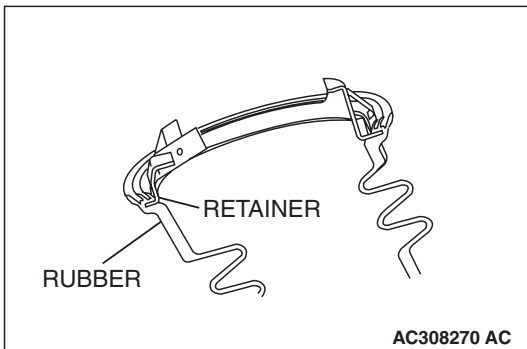
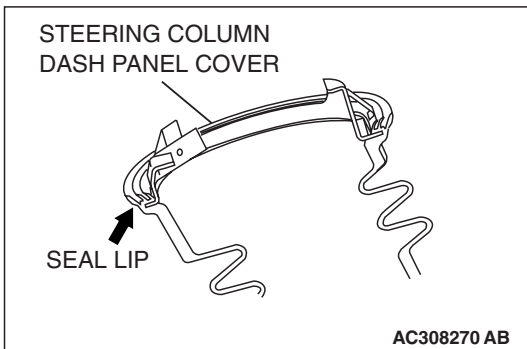

- After installing the steering column dash panel cover, check that the steering column dash panel cover rubber is not disengaged from the retainer. If there is any doubt, release the clips from the body, engage the rubber again and reinstall to the body.

- Tighten the crossmember mounting nuts to  $180 \pm 20$  N·m ( $133 \pm 14$  ft-lb).



## >>D<< FRONT AXLE CROSSMEMBER STAY INSTALLATION

Ensure that the crossmember mounting bolts have been tightened to  $180 \pm 20 \text{ N} \cdot \text{m}$  ( $133 \pm 14 \text{ ft} \cdot \text{lb}$ ), and then install the front crossmember stay with the self-locking nut.

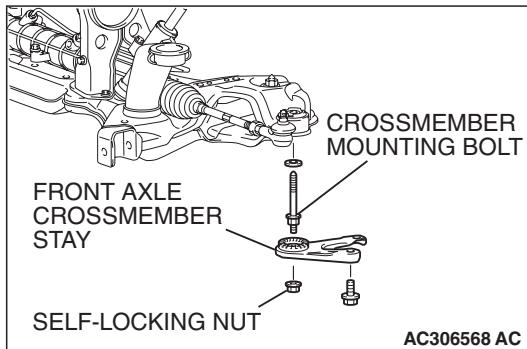

## INSPECTION

M1372011000497

### STEERING GEAR TOTAL PINION TORQUE CHECK

#### Required Special Tool:

- MB991006: Preload Socket

#### **CAUTION**

- When holding the steering gear in a vice, secure its mounting positions. If it is secured in any other place, the gear housing may become deformed or damaged.
- Do not loosen the adjust screw more than 2 rotations.
- If the adjust screw is loosened more than 2 rotations, or if it is removed, replace the steering gear assembly.

1. Using special tool MB991006, rotate the pinion gear at the rate of one rotation in approximately 4 to 6 seconds to check the total pinion torque.

**Standard value:  $0.8 - 1.9 \text{ N} \cdot \text{m}$  ( $7.1 - 16.8 \text{ in} \cdot \text{lb}$ )**  
**[Change in torque:  $0.7 \text{ N} \cdot \text{m}$  ( $6.2 \text{ in} \cdot \text{lb}$ ) or less]**

*NOTE: When measuring, remove the bellows from the rack housing. Measure the pinion torque through the whole stroke of the rack.*

2. If the total pinion torque or the change in torque is outside the standard value, loosen the rack support cover once and retighten it to the specified torque  $12 \pm 2 \text{ N} \cdot \text{m}$  ( $107 \pm 17 \text{ in} \cdot \text{lb}$ ). Then loosen the rack support cover 10 degrees, and check the pinion torque again.

If the total pinion torque cannot be adjusted to within the standard range by adjusting the rack support cover, replace the power steering gear.

### TIE ROD SWING RESISTANCE CHECK

1. Give 10 hard swings to the tie rod.

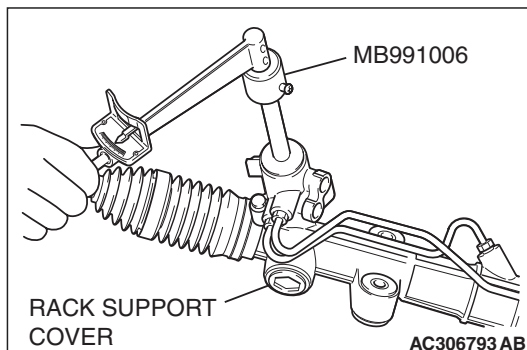

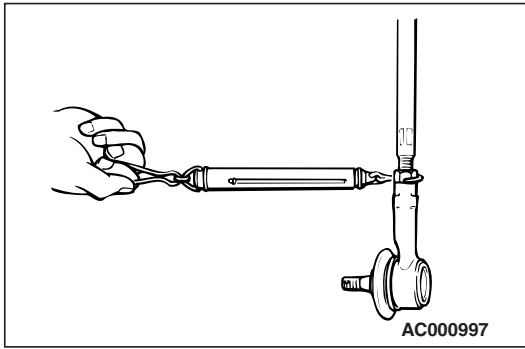

2. Measure the tie rod swing resistance with a spring scale.

**Standard value:**

**3.6 – 17.6 N (0.81 – 3.96 lb)**

**[Swing torque: 1.0 – 4.9 N·m (8.9 – 43.3 in-lb)]**

3. If the measured value exceeds the standard value, replace the tie rod.

4. If the measured value is below the standard value, the tie rod can be re-used if it swings smoothly without excessive play.

**TIE ROD END BALL JOINT DUST COVER CHECK**

1. Check the dust cover for cracks or damage by pushing it with your finger.

2. If the dust cover is cracked or damaged, replace the tie rod end (Refer to P.37-42).

**DISASSEMBLY AND ASSEMBLY**

M1372011100364

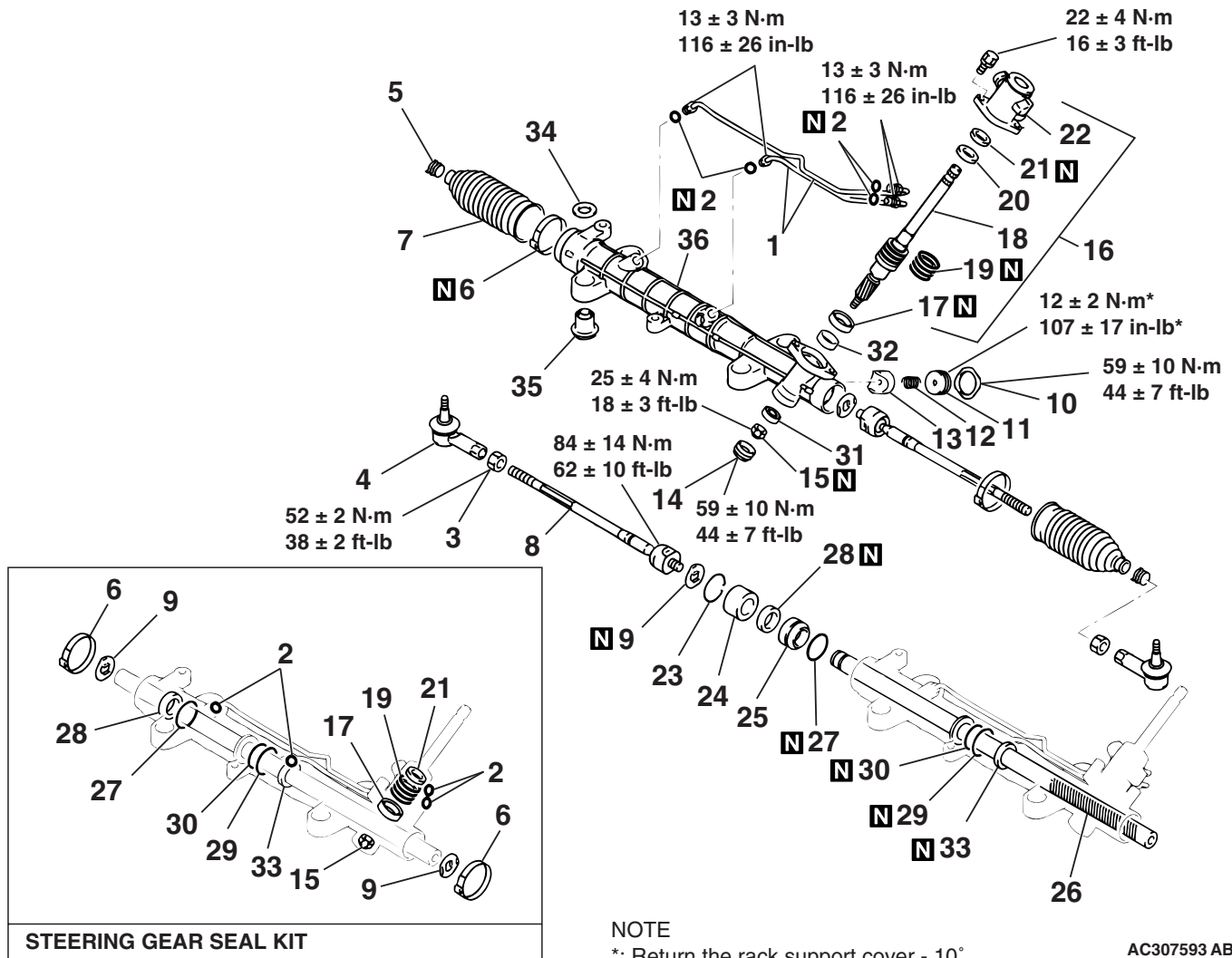

<b>DISASSEMBLY STEPS</b>		<b>DISASSEMBLY STEPS (Continued)</b>
1. POWER STEERING OIL FEED TUBE ASSEMBLY	<<C>> >>J<<	17. OIL SEAL
2. STEERING GEAR INNER O-RING	<<D>> >>I<<	18. PINION AND VALVE ASSEMBLY
>>P<< 3. STEERING GEAR NUT (TIE ROD END JAM NUT)	<<E>> >>H<<	19. SEAL RING
>>P<< 4. TIE ROD END ASSEMBLY	<<E>> >>H<<	20. SPECIAL BEARING
5. STEERING GEAR INNER CLIP	<<F>> >>G<<	21. OIL SEAL
>>O<< 6. STEERING GEAR BAND (BELLOWS BAND)	<<F>> >>G<<	22. VALVE HOUSING
7. STEERING GEAR BELLOWS	>>F<<	23. STEERING GEAR PISTON CLIP (CIRCLIP)
<<A>> >>N<< 8. STEERING TIE ROD	>>F<<	24. STEERING GEAR RACK STOPPER
<<A>> >>N<< 9. STEERING GEAR WASHER (TAB WASHER)	<<G>> >>E<<	25. STEERING GEAR BUSHING (RACK BUSHING)
>>M<< • TOTAL PINION TORQUE ADJUSTMENT	>>D<<	26. STEERING GEAR RACK
>>L<< 10. STEERING GEAR INNER NUT (JAM NUT)	<<H>> >>D<<	27. O-RING
<<B>> >>L<< 11. STEERING GEAR RACK SUPPORT COVER	<<H>> >>D<<	28. OIL SEAL
12. STEERING GEAR RACK SUPPORT SPRING	>>D<<	29. PISTON RING
13. STEERING GEAR RACK SUPPORT	>>D<<	30. O-RING
>>K<< 14. STEERING GEAR PLUG (END PLUG)	<<I>> >>C<<	31. STEERING GEAR PINION BEARING (BALL BEARING)
15. STEERING GEAR INNER NUT	<<J>> >>C<<	32. STEERING GEAR PINION SHAFT UPPER BEARING (NEEDLE ROLLER BEARING)
16. VALVE ASSEMBLY	<<K>> >>B<<	33. OIL SEAL
	<<L>> >>A<<	34. STEERING GEAR CUSHION
	<<L>> >>A<<	35. STEERING GEAR BUSHING
	<<L>> >>A<<	36. RACK HOUSING

**Required Special Tools:**

- MB990927: Installer Adapter
- MB990938: Bar (Snap-in type)
- MB990939: Brass Bar
- MB990996: Lower Arm Bushing Arbor
- MB991006: Preload Socket
- MB991120: Needle Bearing Puller
- MB991152: Dust Cover Installer
- MB991197: Bar (Long type)
- MB991199: Oil Seal Installer
- MB991202: Oil Seal and Bearing Installer
- MB991203: Oil Seal and Bearing Installer
- MB991204: Torque Wrench Socket
- MB991213: Rack Installer
- MB991317: Seal Ring Installer
- MB991561: Boot Band Crimping Tool
- MD998812: Installer Cap
- MD998813: Installer 100
- MD998822: Installer Adapter
- MD998368: Bearing Installer
- MD999569: Camshaft Oil Seal Installer

LUBRICATION AND SEALING POINTS

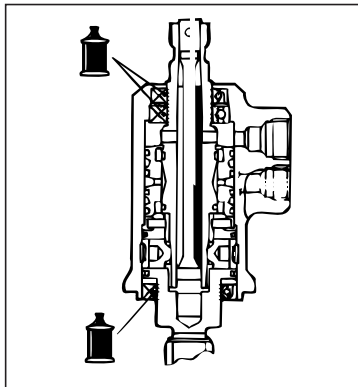

FLUID:  
GENUINE MITSUBISHI  
POWER STEERING FLUID

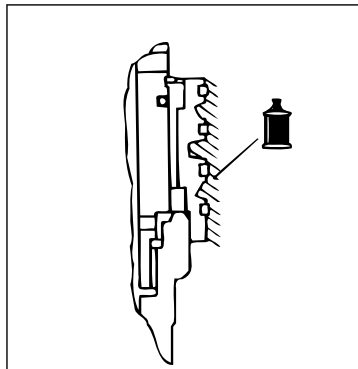

FLUID:  
GENUINE MITSUBISHI  
POWER STEERING FLUID

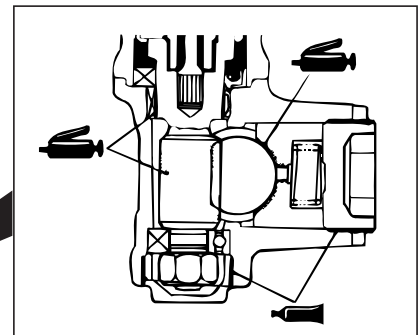

SEALANT:  
3M™ AAD PART NO. 8661,  
8663, 8672, 8678, 8679 OR  
EQUIVALENT

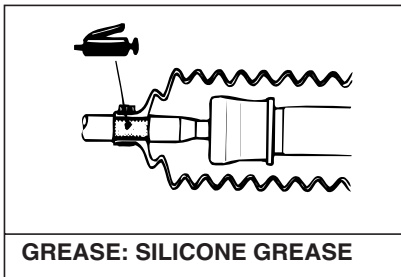
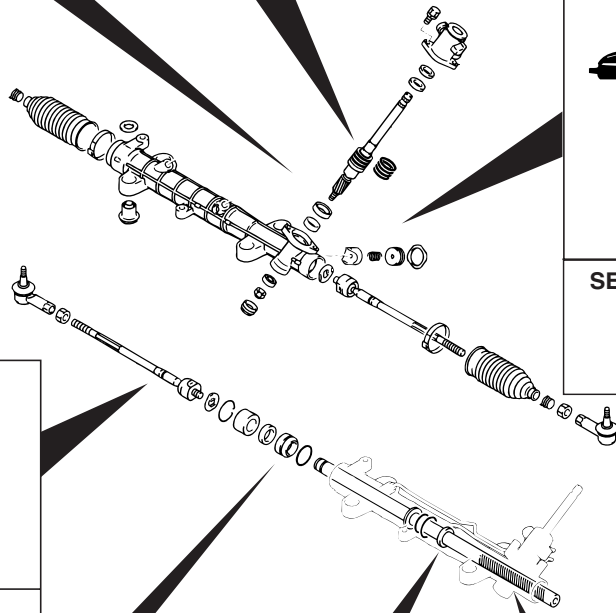

GREASE: SILICONE GREASE

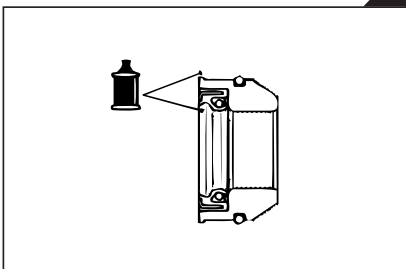

FLUID:  
GENUINE MITSUBISHI POWER  
STEERING FLUID

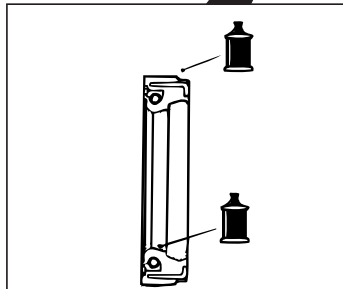

FLUID:  
GENUINE MITSUBISHI  
POWER STEERING FLUID

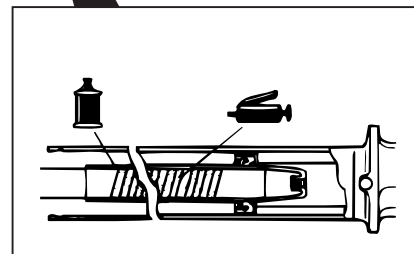

FLUID:  
GENUINE MITSUBISHI POWER  
STEERING FLUID

**DISASSEMBLY SERVICE POINTS**

**<<A>> STEERING TIE ROD/STEERING GEAR WASHER (TAB WASHER) REMOVAL**

Unfold the tab washer which secures the tie rod and rack with a chisel.

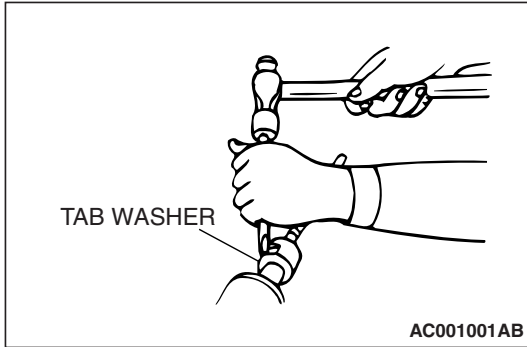

**<<B>> STEERING GEAR RACK SUPPORT COVER REMOVAL**

Using special tool MB991204, remove the rack support cover from the gear box.

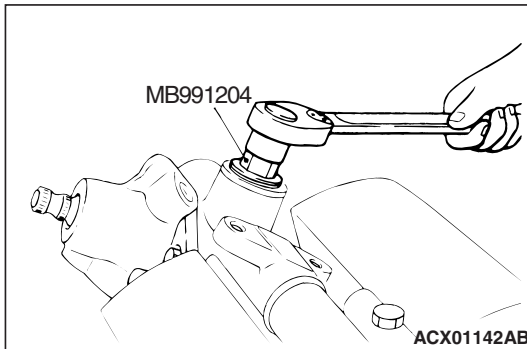

**<<C>> OIL SEAL/PINION AND VALVE ASSEMBLY REMOVAL**

Using a plastic hammer, gently tap the pinion to remove it.

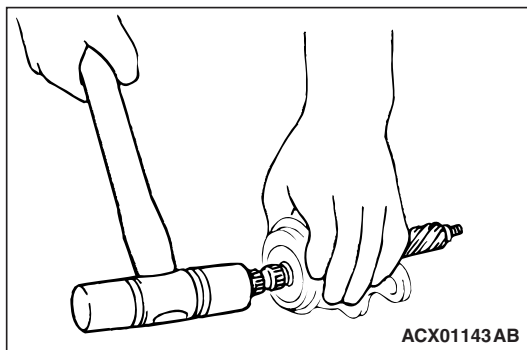

## &lt;&lt;D&gt;&gt; SEAL RING REMOVAL

 CAUTION

When cutting the seal ring, be careful not to damage the pinion and valve assembly or the rack.

Cut the seal ring and remove it from the pinion and valve assembly and the rack.

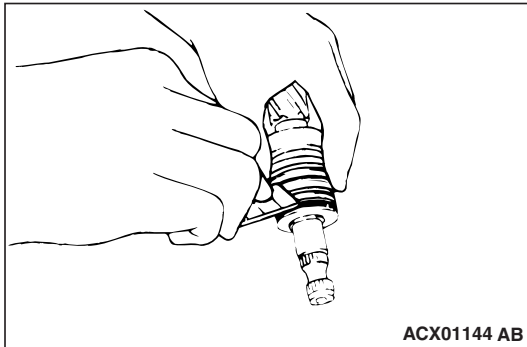

## &lt;&lt;E&gt;&gt; SPECIAL BEARING/OIL SEAL REMOVAL

Using a socket, remove the oil seal and the special bearing from the valve housing simultaneously.

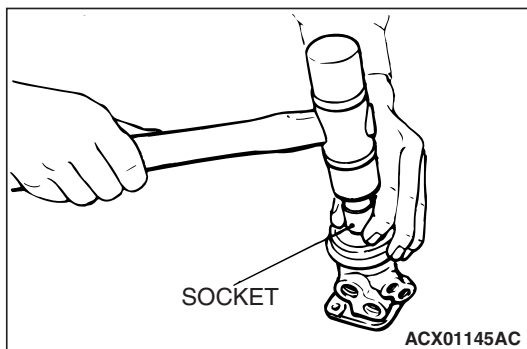

## &lt;&lt;F&gt;&gt; STEERING GEAR PISTON CLIP (CIRCLIP) REMOVAL

Use a screwdriver to remove the circlip from slit of the rack stopper.

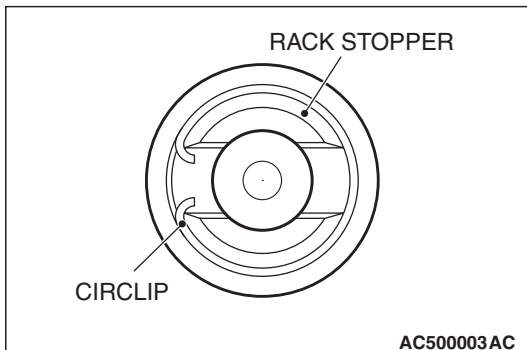

## &lt;&lt;G&gt;&gt; STEERING GEAR RACK REMOVAL

Pull out the rack slowly. Take out the rack stopper and the rack bushing at the same time.

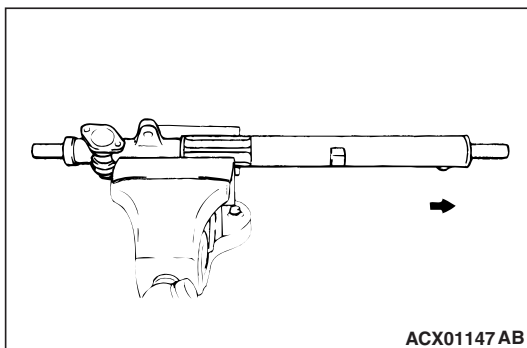

### <<H>> OIL SEAL REMOVAL

**⚠ CAUTION**

Do not damage oil seal press fitting surface.  
Partially pry the oil seal and remove it from the rack bushing.

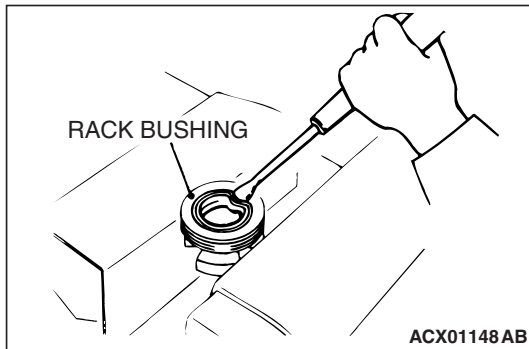

### <<I>> STEERING GEAR PINION BEARING (BALL BEARING) REMOVAL

Use a brass bar or special tool MB990939 to remove the ball bearing from the gear housing.

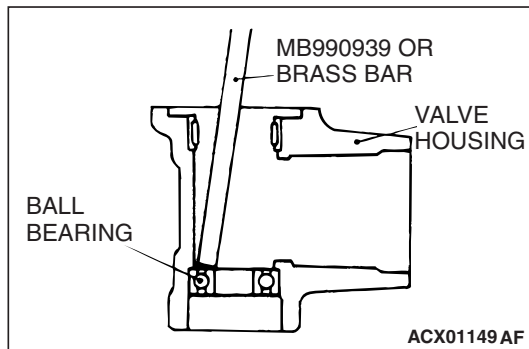

### <<J>> STEERING GEAR PINION SHAFT UPPER BEARING (NEEDLE ROLLER BEARING) REMOVAL

**⚠ CAUTION**

Do not open special tool MB991120 excessively to prevent damaging housing interior.

Use special tool MB991120 to remove the needle roller bearing from the rack housing.

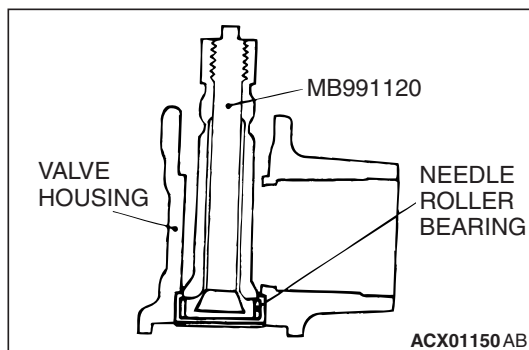

## &lt;&lt;K&gt;&gt; OIL SEAL REMOVAL

**⚠ CAUTION**

Be careful not to damage the inner surface of the rack cylinder of the gear housing.

Use a piece of pipe or similar tool to remove the oil seal from the gear housing.

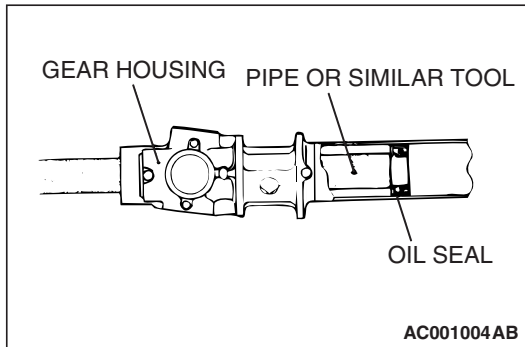

## &lt;&lt;L&gt;&gt; STEERING GEAR BUSHING REMOVAL

Use special tools MD998812, MD998813, MD998822 and MD998368 to remove the steering gear bushing.

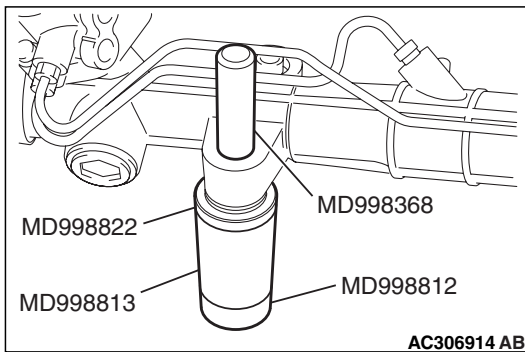

## ASSEMBLY SERVICE POINTS

## &gt;&gt;A&lt;&lt; STEERING GEAR BUSHING INSTALLATION

Use special tools MD999569 and MB990996 to press-fit the steering gear bushing.

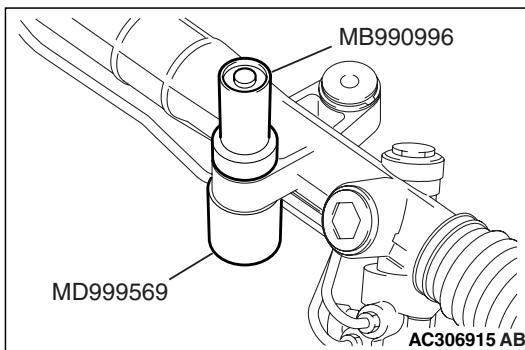

## &gt;&gt;B&lt;&lt; OIL SEAL INSTALLATION

1. Apply a coating of GENUINE MITSUBISHI POWER STEERING FLUID to both sides of the oil seal.



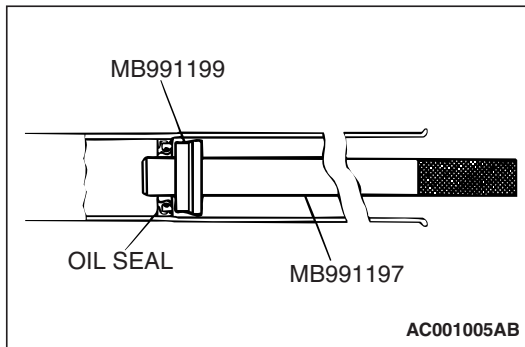

- Using special tools MB991199 and MB991197, press the oil seal into the rack housing.

### >>C<< STEERING GEAR PINION SHAFT UPPER BEARING (NEEDLE ROLLER BEARING)/STEERING GEAR PINION BEARING (BALL BEARING) INSTALLATION

#### ⚠ CAUTION

Press-fit the bearing straight. The valve housing is aluminum, and may become deformed if the bearing is press-fitted on an angle.

- Apply GENUINE MITSUBISHI POWER STEERING FLUID to the housing, bearing and oil seal press fitting surface.
- Press fit the needle roller bearing with special tools MB990938 and MB991202.

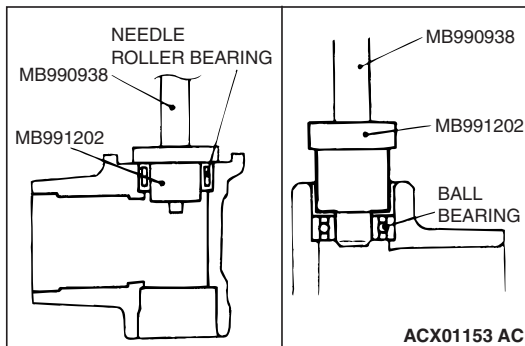

### >>D<< OIL SEAL/O-RING INSTALLATION

- Apply a coating of GENUINE MITSUBISHI POWER STEERING FLUID to the outside of the oil seal and O-ring.
- Use special tool MB990927 to press fit oil seal until it touches the rack bush end.

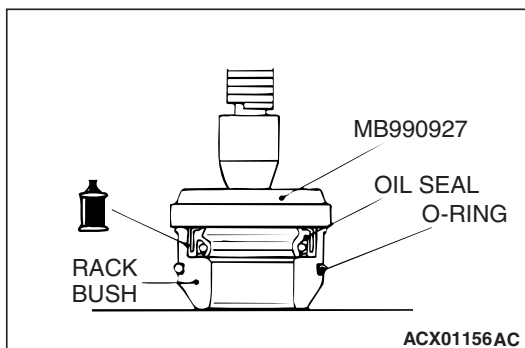

## &gt;&gt;E&lt;&lt; STEERING GEAR RACK INSTALLATION

**⚠ CAUTION**

**Do not close the vent hole in the rack with grease.**

1. Apply a coating of multipurpose grease to the rack teeth face.

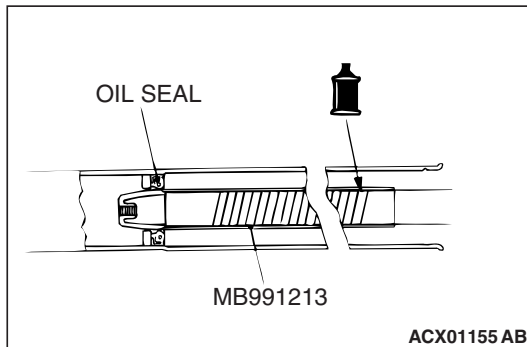
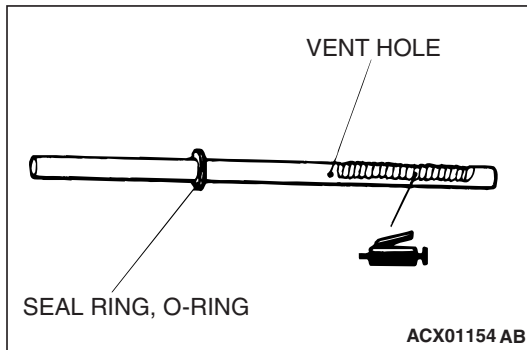

2. Cover the rack serrations with special tool MB991213.
3. Apply GENUINE MITSUBISHI POWER STEERING FLUID to special tool MB991213.
4. Align the center of the oil seal with the rack to prevent the retainer spring from slipping. Slowly insert the rack from power the cylinder side.

## &gt;&gt;F&lt;&lt; STEERING GEAR BUSHING (RACK BUSHING) INSTALLATION

**⚠ CAUTION**

**Do not allow oil seal retainer spring to slip out.**

Wrap the rack end with vinyl tape, apply a coating of GENUINE MITSUBISHI POWER STEERING FLUID, and then install the rack bushing and rack stopper.

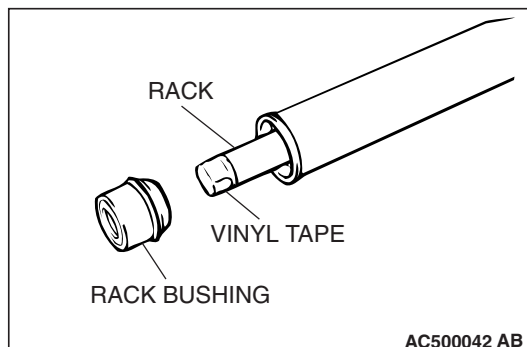

### >>G<< STEERING GEAR PISTON CLIP (CIRCLIP) INSTALLATION

Insert claw of circlip in a slit of rack stopper. Then set firmly the circlip in a ditch of steering gear housing.

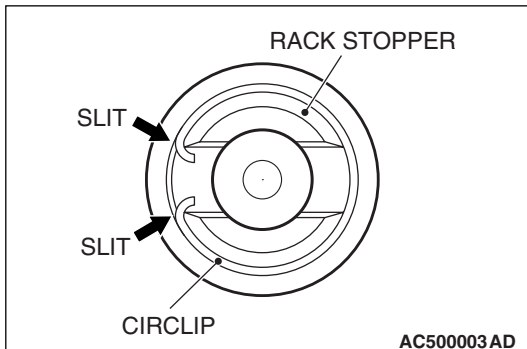

### >>H<< OIL SEAL/SPECIAL BEARING INSTALLATION

Apply a coating of GENUINE MITSUBISHI POWER STEERING FLUID to the outside of the oil seal/special bearing. Using special tools MB990938 and MB991203, press the oil seal/special bearing into the valve housing.

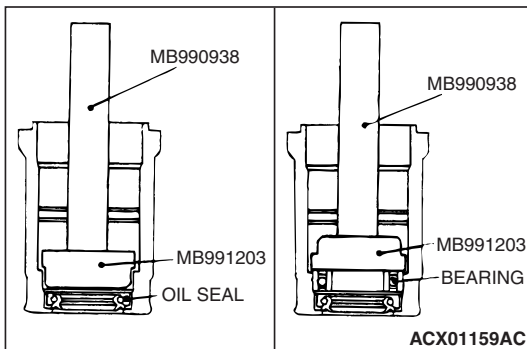

### >>I<< SEAL RING INSTALLATION

Because the seal rings expand after installation, tighten after installing by using special tool MB991317 to compress the seal rings, or press down by hand.

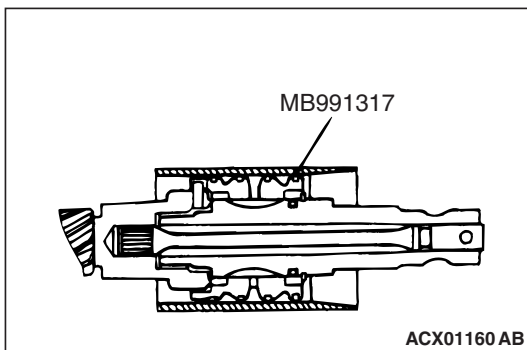

## &gt;&gt;J&lt;&lt; OIL SEAL INSTALLATION

**CAUTION**

To eliminate a seal malfunction at the valve housing alignment surface, the upper surface of the oil seal should project outward approximately 1 mm (0.04 inch) from the housing edge surface.

Using special tool MB991152, press the oil seal into the valve housing.

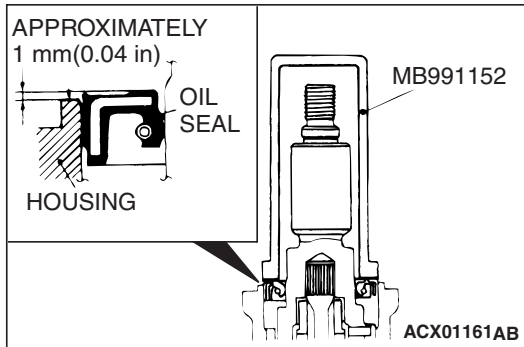

## &gt;&gt;K&lt;&lt; STEERING GEAR PLUG (END PLUG) INSTALLATION

1. Apply 3M™ AAD Part number 8661, 8663, 8672, 8678, 8679 or equivalent to the threaded part of the end plug.
2. Secure the threaded portion of the end plug at two places by using a punch.

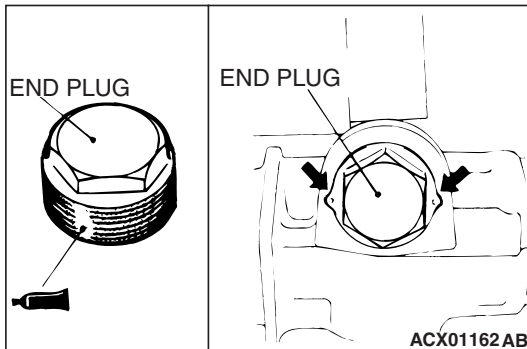

## &gt;&gt;L&lt;&lt; STEERING GEAR RACK SUPPORT COVER/STEERING GEAR INNER NUT (JAM NUT) INSTALLATION

1. Position the rack at its center.
2. Apply 3M™ AAD Part number 8661, 8663, 8672, 8678, 8679 or equivalent to the threaded part of the rack support cover.
3. Use special tool MB991204 to tighten the rack support cover to  $12 \pm 2$  N·m ( $107 \pm 17$  in-lb).
4. Turn the rack support cover 10 degree angle counterclockwise.
5. Use special tool MB991204 to hold the rack support cover, and then tighten the jam nut to  $59 \pm 10$  N·m ( $44 \pm 7$  ft-lb).

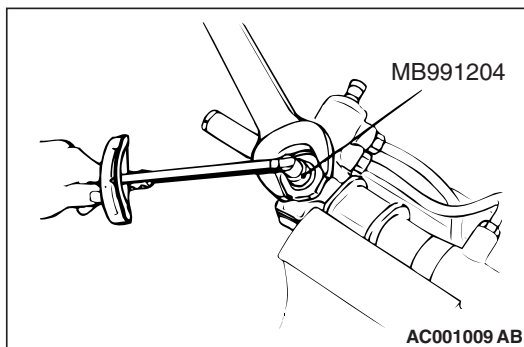

### >>M<< TOTAL PINION TORQUE ADJUSTMENT

#### ⚠ CAUTION

- Be sure there is no ratcheting or catching when operating the rack towards the shaft.
- Measure the total pinion torque through the whole stroke of the rack.

1. Using special tool MB991006, rotate the pinion shaft at the rate of one rotation in 4 to 6 seconds to check the total pinion torque and the change in torque.

#### Standard value:

**Total pinion torque: 0.8 –1.9 N· m (7.1 –16.8 in-lb)**

**[Change in torque: 0.7 N· m (6.2 in-lb) or less]**

#### ⚠ CAUTION

When adjusting, set at the highest value of the standard value range.

*NOTE: If the total pinion torque cannot be adjusted to the standard value within the standard range, replace the power steering gear and linkage assembly.*

2. If the total pinion torque or the change in torque is outside the standard value, loosen the rack support cover once and retighten it to the specified torque  $12 \pm 2$  N· m ( $107 \pm 17$  in-lb). And then loosen the rack support cover 10 degrees, and check the pinion torque again.

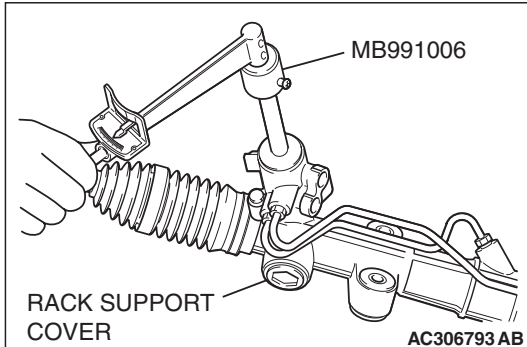

### >>N<< STEERING GEAR WASHER (TAB WASHER)/STEERING TIE ROD INSTALLATION

After installing the tie rod to the rack, fold tab washer end (two locations) to tie rod notch.

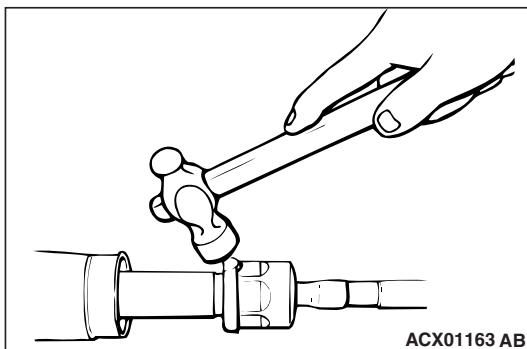

### >>O<< STEERING GEAR BAND (BELLOWS BAND) INSTALLATION

1. Turn the adjusting bolt of special tool MB991561 to adjust the opening dimension (W) to the standard value.

*NOTE: The dimension (W) is adjusted by approximately 0.7 mm (0.03 inch) per one turn.*

*NOTE: Do not turn the adjusting bolt more than one turn.*

**Standard value (W): 1.9 mm (0.07 inch)**

**<When more than 1.9 mm (0.07 inch)>: Screw in the adjusting bolt.**

**<When less than 1.9 mm (0.07 inch)>: Loosen the adjusting bolt.**

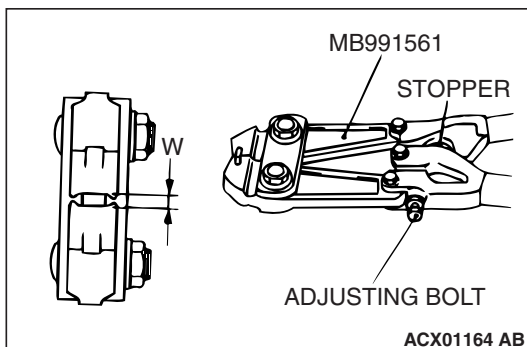

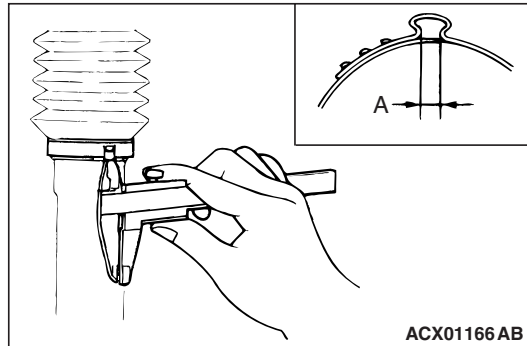
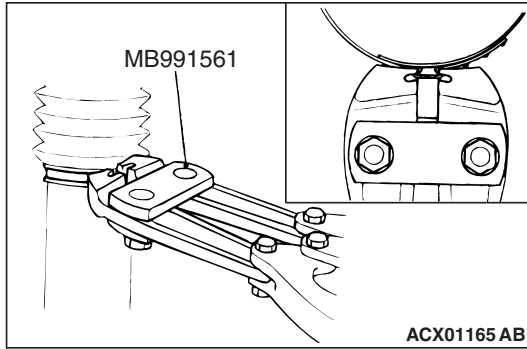
**⚠ CAUTION**

- Hold the rack housing, and use special tool MB991561 to crimp the bellows band securely.
  - Crimp the bellows band until special tool MB991561 touches the stopper.
2. Use special tool MB991561 to crimp the bellows band.

3. Check that crimped width (A) is within the standard value.
- Standard value (A): 1.4 –1.8 mm (0.06 –0.07 inch)**  
**<When more than 1.8 mm (0.07 inch)>: Readjust the dimension (W) of step (1) to the value calculated by the following equation, and repeat step (2).**  
 $W = 5.5 \text{ mm (0.22 inch)} - A$  [Example: if (A) is 1.9 mm (0.07 inch), (W) is 3.6 mm (0.14 inch).]  
**<When less than 1.4 mm (0.06 inch)>: Remove the bellows band, readjust the dimension (W) of step (1) to the value calculated by the following equation, and use a new bellows band to repeat steps (2) to (3).**  
 $W = 5.5 \text{ mm (0.22 inch)} - A$  [Example: if (A) is 1.3 mm (0.05 inch), (W) is 4.2 mm (0.17 inch).]

### >>P<< TIE ROD END ASSEMBLY/STEERING GEAR NUT (TIE ROD END JAM NUT) INSTALLATION

Screw in the tie rod end to achieve the right and left length as illustrated. Lock with the jam nut.

*NOTE: The locking nuts must be tightened securely only after the steering gear is installed and toe is adjusted.*

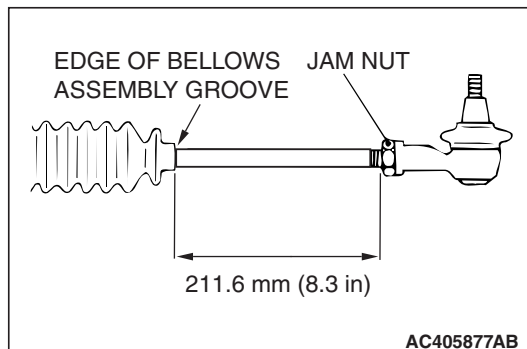
**INSPECTION**

M1372004400114

**RACK**

- Check the rack tooth surfaces for damage or wear.
- Check the oil seal contact surfaces for uneven wear.
- Check the rack for bends.

**PINION AND VALVE ASSEMBLY**

- Check the pinion gear tooth surfaces for damage or wear.
- Check for worn or defective seal ring.

**BEARING**

- Check for roughness or abnormal noise during bearing operation.
- Check the bearing for play.
- Check the needle roller bearings for roller slip-off.

**OTHERS**

- Check the cylinder inner surface of the rack housing for damage.
- Check the boots for damage, cracking or deterioration.
- Check the rack support for uneven wear or dents.
- Check the rack bushing for uneven wear or damage.

# POWER STEERING OIL PUMP ASSEMBLY

## REMOVAL AND INSTALLATION <2.4L ENGINE>

M1372005200618

**Pre-removal Operation**

- Side Under Cover (RH) Removal (Refer to GROUP 51, Under Cover P.51-8).
- Power Steering Fluid Draining (Refer to P.37-22).

**Post-installation Operation**

- Power Steering Fluid Supplying and Bleeding (Refer to P.37-22).
- Drive Belt Tension Adjusting (Refer to GROUP 00, Maintenance Service –Drive Belts P.00-52).
- Side Under Cover (RH) Installation (Refer to GROUP 51, Under Cover P.51-8).

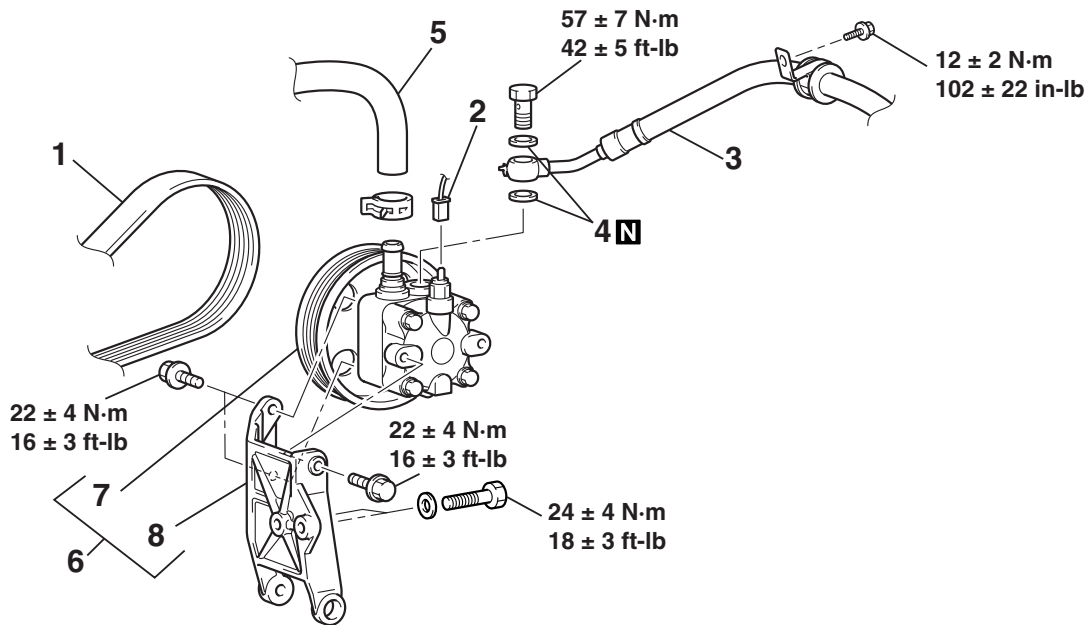

AC405938 AB

**REMOVAL STEPS**

1. DRIVE BELT (REFER TO GROUP 11A, ENGINE ASSEMBLY P.11A-17 )
2. PRESSURE SWITCH CONNECTOR
3. PRESSURE HOSE
4. GASKET
- >>A<< 5. SUCTION HOSE

**REMOVAL STEPS (Continued)**

6. POWER STEERING OIL PUMP AND BRACKET ASSEMBLY
7. POWER STEERING OIL PUMP BRACKET
8. POWER STEERING OIL PUMP ASSEMBLY

### INSTALLATION SERVICE POINT

**>>A<< SUCTION HOSE INSTALLATION**

Install the suction hose so that the marking is positioned as shown in the illustration.

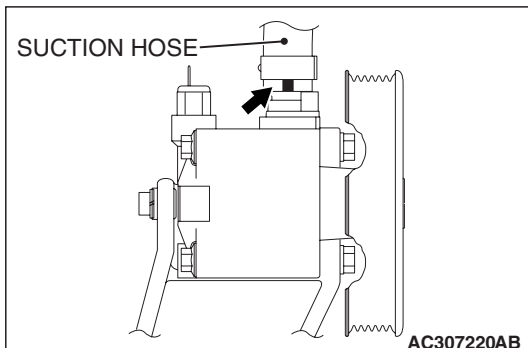

AC307220AB



**REMOVAL AND INSTALLATION <3.8L ENGINE>**

M1372005200629

**Pre-removal Operation**

- Side Under Cover (RH) Removal (Refer to GROUP 51, Under Cover P.51-8).
- Strut Tower Bar (Refer to GROUP 42, Strut Tower Bar P.42-12).
- Power Steering Fluid Draining (Refer to P.37-22).

**Post-installation Operation**

- Power Steering Fluid Supplying and Bleeding (Refer to P.37-22).
- Drive Belt Tension Adjusting (Refer to GROUP 00, Maintenance Service –Drive Belts P.00-52).
- Strut Tower Bar (Refer to GROUP 42, Strut Tower Bar P.42-12).
- Side Under Cover (RH) Installation (Refer to GROUP 51, Under Cover P.51-8).

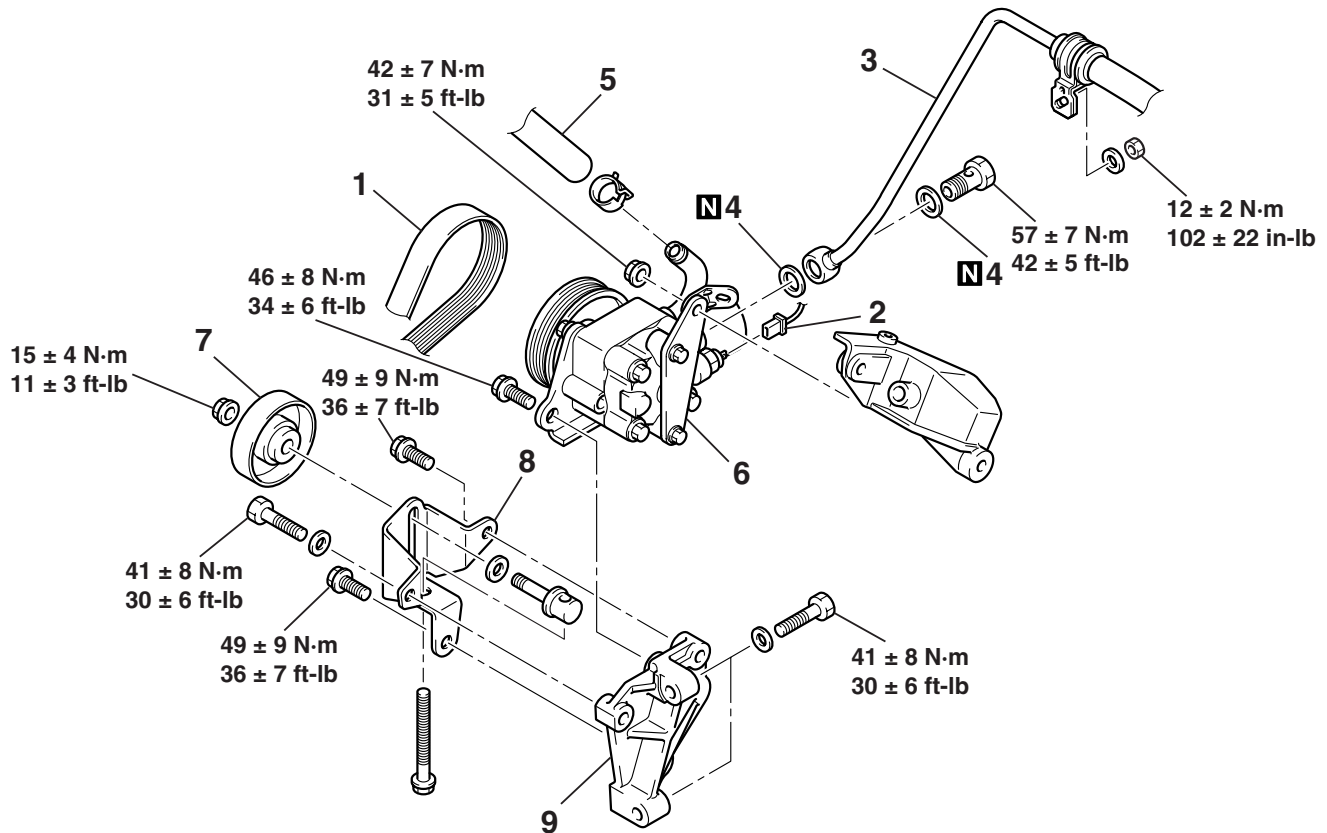

AC405895 AB

**REMOVAL STEPS**

1. DRIVE BELT (REFER TO GROUP 11C, ENGINE ASSEMBLY P.11C-22.)
2. PRESSURE SWITCH CONNECTOR <<A>>
3. PRESSURE HOSE
4. GASKET
- >>A<< 5. SUCTION HOSE
  - CONNECTION OF STABILIZER BAR AND STABILIZER LINK (REFER TO GROUP 33, STABILIZER BAR P.33-20.)

**REMOVAL STEPS (Continued)**

- STEERING GEAR AND LINKAGE PROTECTOR (REFER TO P.37-34.)
- 6. POWER STEERING OIL PUMP ASSEMBLY
- 7. BELT TENSIONER PULLEY
- 8. BELT TENSIONER BRACKET
- 9. POWER STEERING OIL PUMP BRACKET

**REMOVAL SERVICE POINT****<<A>> POWER STEERING OIL PUMP ASSEMBLY  
REMOVAL**

Fully disconnect the stabilizer from the stabilizer link. Turn the steering wheel fully to left, and remove the power steering oil pump assembly.

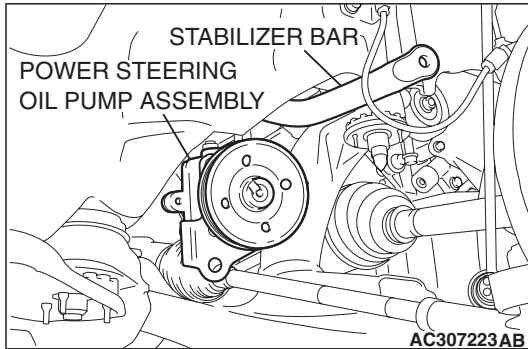
**INSTALLATION SERVICE POINT****>>A<< SUCTION HOSE INSTALLATION**

Install the suction hose so that the marking is positioned as shown in the illustration.

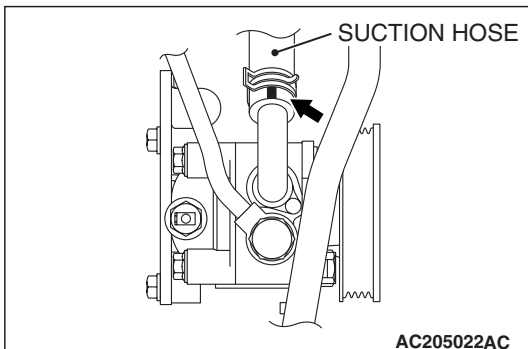
**INSPECTION**

- Check the drive belt for cracks.
- Check the pulley for uneven rotation.

M1372005300206

# POWER STEERING HOSES

## REMOVAL AND INSTALLATION

M1372005700743

### Pre-removal Operation

- Side Under Cover (RH) Removal (Refer to GROUP 51, Under Cover P.51-8).
- Power Steering Fluid Draining (Refer to P.37-22).
- Front Bumper and Radiator Grille Removal (Refer to GROUP 51, Front Bumper and Radiator Grille P.51-2).

### Post-installation Operation

- Front Bumper and Radiator Grille Removal (Refer to GROUP 51, Front Bumper and Radiator Grille P.51-2).
- Power Steering Fluid Supplying and Bleeding (Refer to P.37-22).
- Side Under Cover (RH) Installation (Refer to GROUP 51, Under Cover P.51-8).

<2.4 L ENGINE>

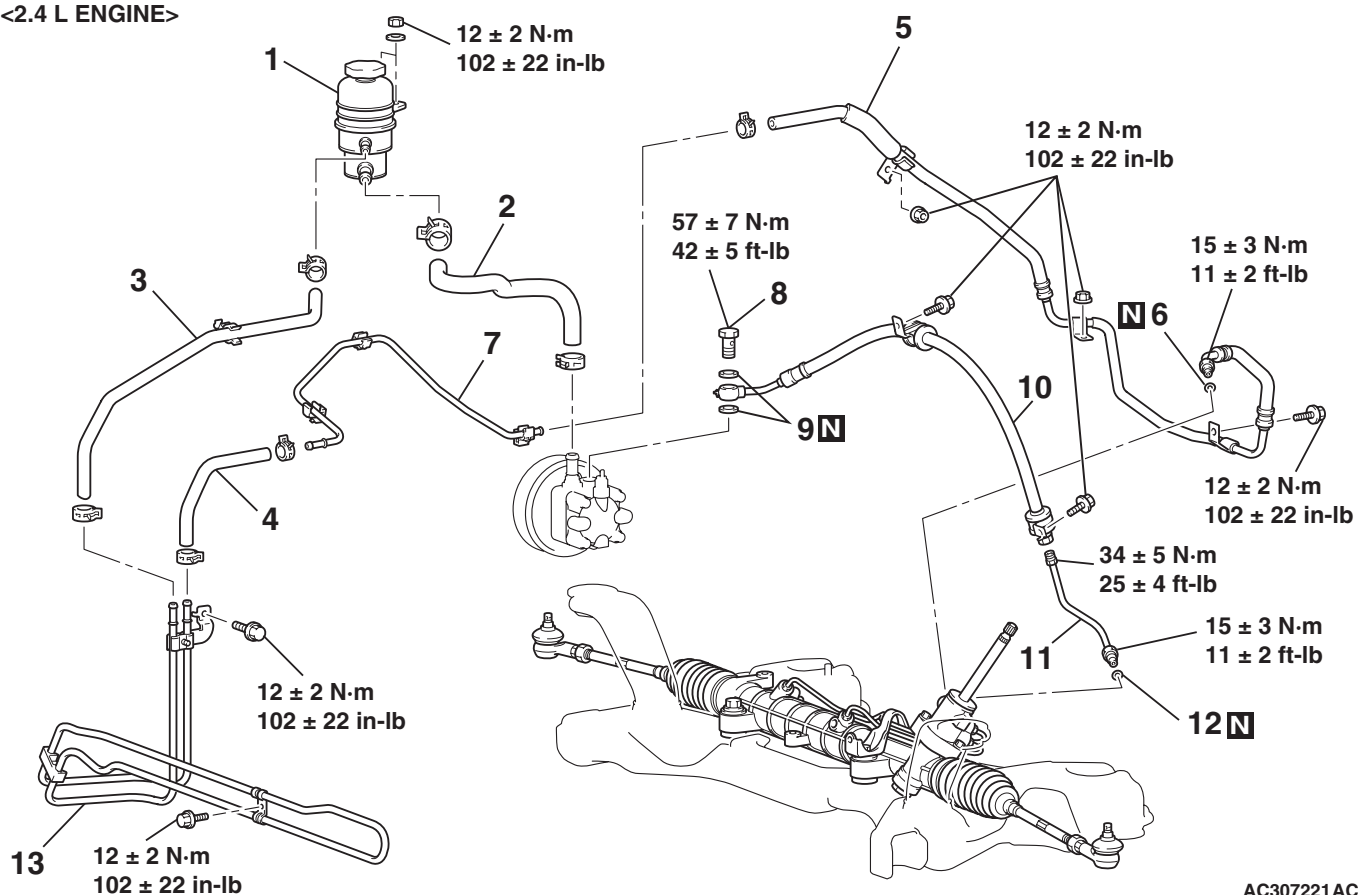

AC307221AC

<3.8 L ENGINE>

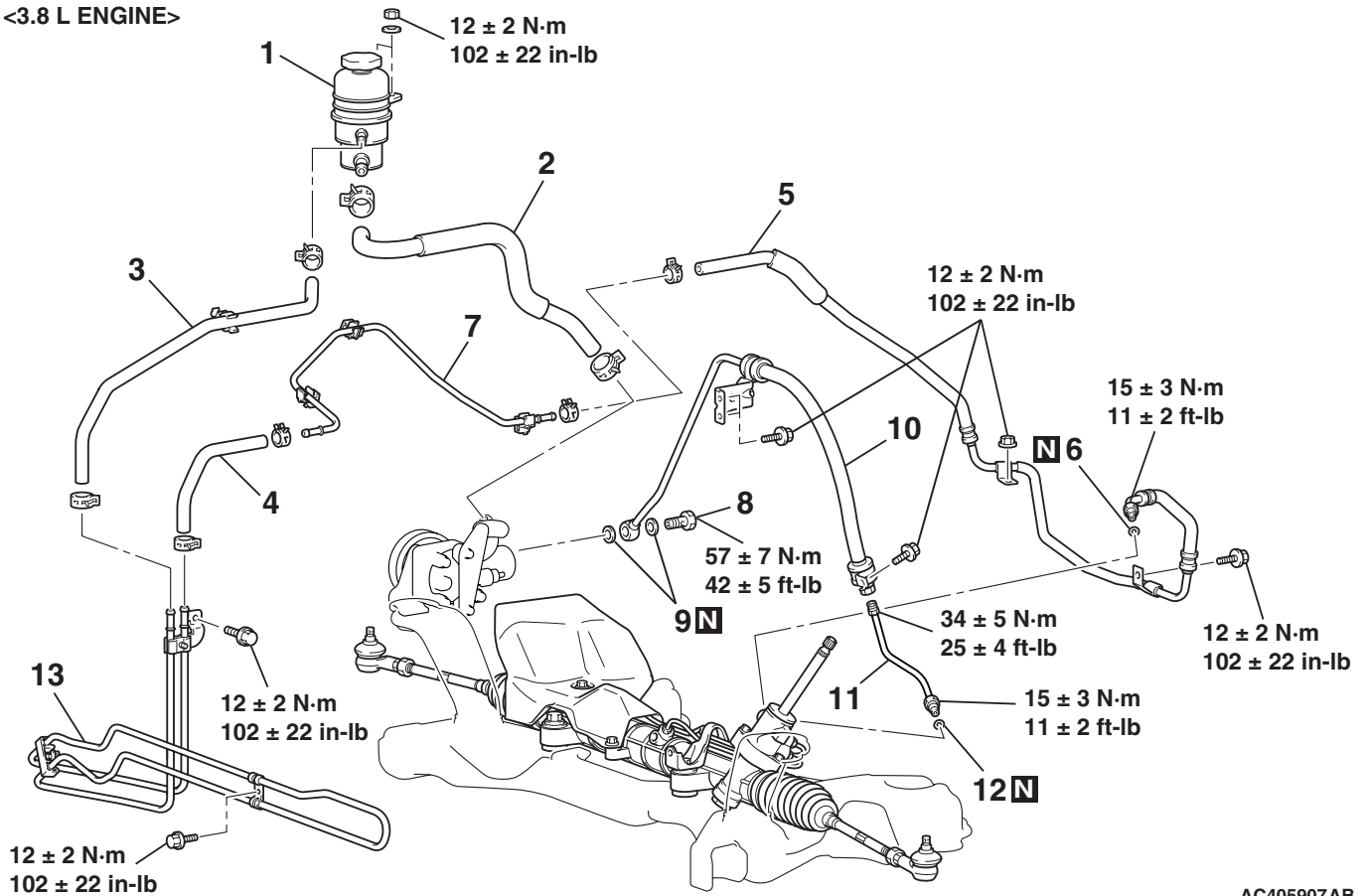

AC405907AB

**REMOVAL STEPS**

1. OIL RESERVOIR
- >>F<< 2. SUCTION HOSE
- >>E<< 3. RETURN HOSE (M)
- >>D<< 4. RETURN HOSE (R)
- >>C<< 5. RETURN TUBE ASSEMBLY
6. O-RING
- >>B<< 7. RETURN TUBE (R)

**REMOVAL STEPS (Continued)**

8. EYE BOLT
9. GASKET
- >>A<< 10. PRESSURE HOSE
- >>A<< 11. PRESSURE TUBE ASSEMBLY
12. O-RING
13. COOLER TUBE ASSEMBLY

### INSTALLATION SERVICE POINTS

#### >>A<< PRESSURE TUBE ASSEMBLY/PRESSURE HOSE INSTALLATION

Align the markings as shown in the illustration and tighten the nut.

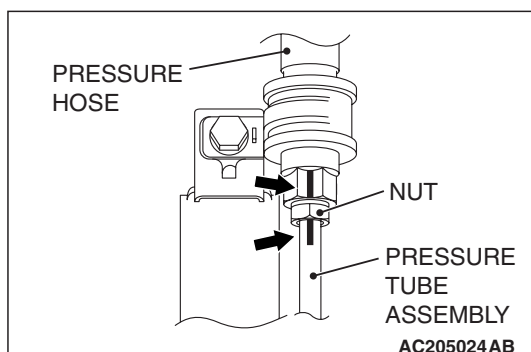
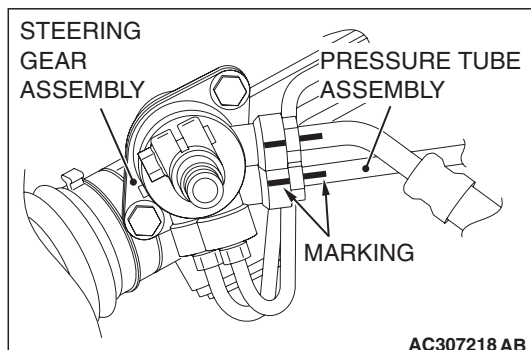

#### >>B<< RETURN TUBE (R) INSTALLATION

Install the return tube (R) so that the marking is positioned as shown in the illustration.

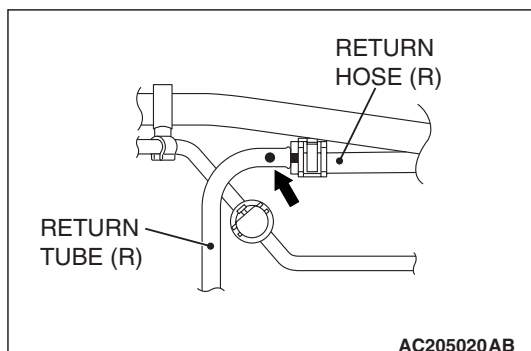

**>>C<< RETURN TUBE ASSEMBLY  
INSTALLATION**

1. Install the return tube assembly so that the marking is positioned as shown in the illustration.
2. Align the markings as shown in the illustration and tighten the nut.

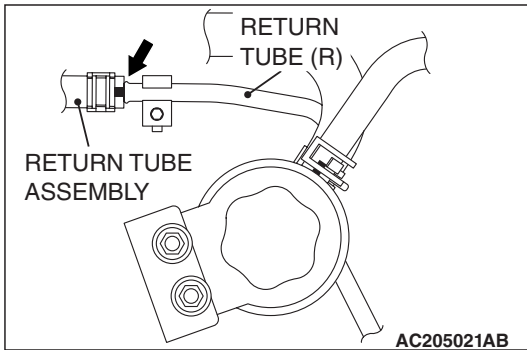
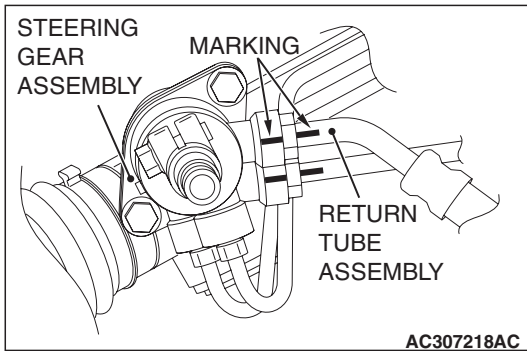

**>>D<< RETURN HOSE (R) INSTALLATION**

Install the return hose (R) so that the markings are positioned as shown in the illustration.

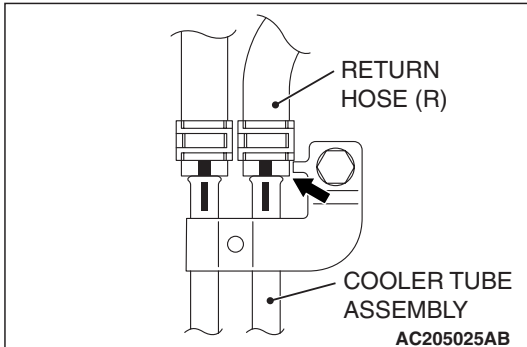
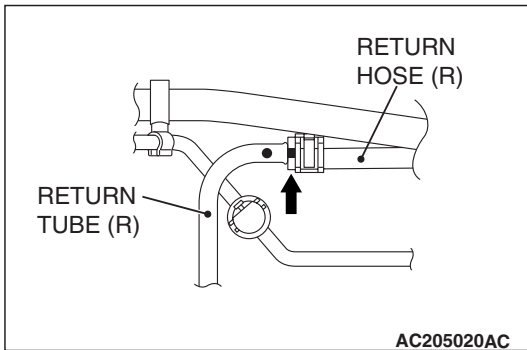

**>>E<< RETURN HOSE (M) INSTALLATION**

Install the return hose (M) so that the markings are positioned as shown in the illustration.

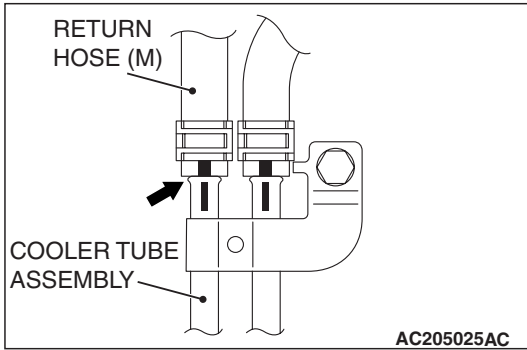
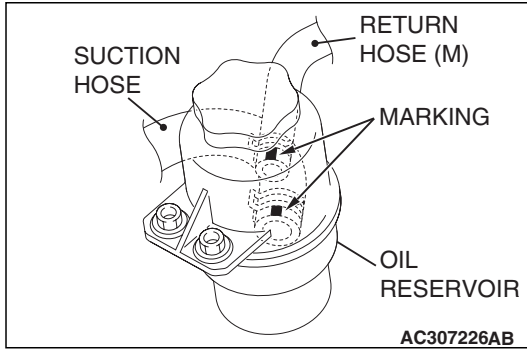

>>F<< SUCTION HOSE INSTALLATION

Install the suction hose so that the marking is positioned as shown in the illustration.

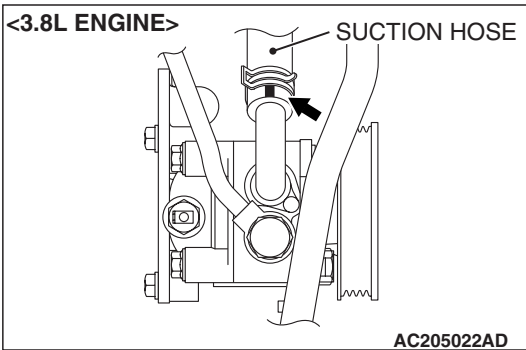
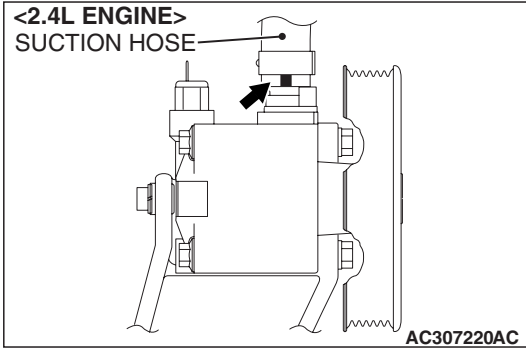
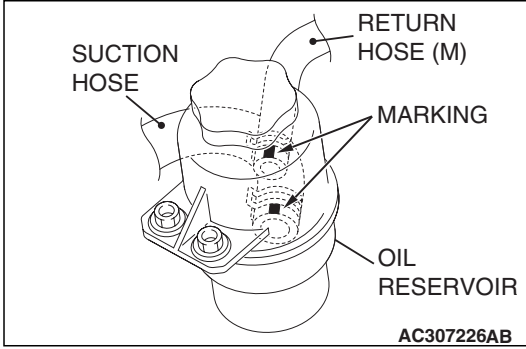



## SPECIFICATIONS

### FASTENER TIGHTENING SPECIFICATIONS

M1372008400406

ITEM	SPECIFICATION
<b>Power steering gear box and linkage (removal and installation)</b>	
Crossmember mounting bolt	180 ± 20 N· m (133 ± 14 ft-lb)
Crossmember mounting nut	180 ± 20 N· m (133 ± 14 ft-lb)
Front axle crossmember stay mounting bolt and nut	83 ± 12 N· m (61 ± 9 ft-lb)
Lower arm and crossmember connecting nut	165 ± 15 N· m (122 ± 11 ft-lb)
Power steering gear bracket mounting bolt	58 ± 7 N· m (43 ± 5 ft-lb)
Pressure tube flare nut	15 ± 3 N· m (11 ± 2 ft-lb)
Pressure hose clamp bolt and nut	12 ± 2 N· m (102 ± 22 in-lb)
Rear roll stopper mounting bolt	58 ± 7 N· m (43 ± 5 ft-lb)
Rear roll stopper to power steering gear bracket connecting bolt	58 ± 7 N· m (43 ± 5 ft-lb)
Rear roll stopper to rear roll stopper bracket connecting nut	58 ± 7 N· m (43 ± 5 ft-lb)
Return tube flare nut	15 ± 3 N· m (11 ± 2 ft-lb)
Return tube clamp bolt and nut	12 ± 2 N· m (102 ± 22 in-lb)
Stabilizer bracket	58 ± 7 N· m (43 ± 5 ft-lb)
Steering column assembly and steering gear connecting bolt	18 ± 2 N· m (13 ± 2 ft-lb)
Steering gear and linkage mounting bolt	83 ± 12 N· m (61 ± 9 ft-lb)
Steering gear and linkage protector mounting bolt	12 ± 2 N· m (102 ± 22 in-lb)
Tie rod end to knuckle self-locking nut	29 ± 4 N· m (21 ± 3 ft-lb)
<b>Power steering gear box and linkage (disassembly and assembly)</b>	
Power steering oil feed tube assembly flare nut	13 ± 3 N· m (116 ± 26 in-lb)
Steering gear inner nut (pinion and valve assembly jam nut)	25 ± 4 N· m (18 ± 3 ft-lb)
Steering gear inner nut (rack support cover jam nut)	59 ± 10 N· m (44 ± 7 ft-lb)
Steering gear nut (tie rod end jam nut)	52 ± 2 N· m (38 ± 2 ft-lb)
Steering gear plug (end plug)	59 ± 10 N· m (44 ± 7 ft-lb)
Steering gear rack support cover	12 ± 2 N· m (107 ± 17 in-lb)
Steering tie rod	84 ± 14 N· m (62 ± 10 ft-lb)
Valve housing bolt	22 ± 4 N· m (16 ± 3 ft-lb)
<b>Power steering hose</b>	
Cooler tube clamp bolt	12 ± 2 N· m (102 ± 22 in-lb)
Oil pump eye bolt	57 ± 7 N· m (42 ± 5 ft-lb)
Oil reservoir nut	12 ± 2 N· m (102 ± 22 in-lb)
Pressure hose, pressure tube, return tube clamp bolt	12 ± 2 N· m (102 ± 22 in-lb)
Pressure hose and pressure tube connecting nut	34 ± 5 N· m (25 ± 4 ft-lb)
Pressure tube, return tube flare nut	15 ± 3 N· m (11 ± 2 ft-lb)
Return tube clamp nut	12 ± 2 N· m (102 ± 22 in-lb)
<b>Power steering oil pump &lt;2.4L ENGINE&gt;</b>	
Oil pump eye bolt	57 ± 7 N· m (42 ± 5 ft-lb)

ITEM		SPECIFICATION
Power steering oil pump mounting bolt		22 ± 4 N· m (16 ± 3 ft-lb)
Power steering oil pump bracket mounting bolt		24 ± 4 N· m (18 ± 3 ft-lb)
Pressure hose clamp bolt		12 ± 2 N· m (102 ± 22 in-lb)
<b>Power steering oil pump &lt;3.8L ENGINE&gt;</b>		
Belt tensioner bracket to power steering pump bracket connecting bolt (long)		41 ± 8 N· m (30 ± 6 ft-lb)
Belt tensioner bracket to power steering pump bracket connecting bolt (short)		49 ± 9 N· m (36 ± 7 ft-lb)
Belt tensioner pulley mounting nut		15 ± 4 N· m (11 ± 3 ft-lb)
Oil pump eye bolt		57 ± 7 N· m (42 ± 5 ft-lb)
Power steering oil pump mounting bolt		46 ± 8 N· m (34 ± 6 ft-lb)
Power steering oil pump mounting nut		42 ± 7 N· m (31 ± 5 ft-lb)
Power steering oil pump bracket mounting bolt		41 ± 8 N· m (30 ± 6 ft-lb)
Pressure hose clamp nut		12 ± 2 N· m (102 ± 22 in-lb)
<b>Steering shaft</b>		
Steering column assembly and steering gear connecting bolt		18 ± 2 N· m (13 ± 2 ft-lb)
Steering column assembly mounting bolt		12 ± 2 N· m (102 ± 22 in-lb)
<b>Steering wheel</b>		
Steering wheel dynamic damper		3.9 ± 0.9 N· m (35 ± 8 in-lb)
Steering wheel mounting nut		41 ± 8 N· m (30 ± 6 ft-lb)
Torx screw		9.0 ± 2.0 N· m (80 ± 17 in-lb)

**GENERAL SPECIFICATIONS**

M1372000200323

ITEM		SPECIFICATION	
		2.4L ENGINE	3.8L ENGINE
Steering wheel	Type	4-spoke type	4-spoke type
	Outside diameter mm (in)	370 (14.6)	370 (14.6)
	Maximum number of turns	2.64	2.64
Steering column	Column mechanism	Shock absorbing mechanism and Tilt steering mechanism	
Power steering type		Integral type	Integral type
Oil pump	Type	vane pump	vane pump
	Basic discharge amount cm <sup>3</sup> /rev. (cu in/rev)	9.6 (0.59)	9.6 (0.59)
	Relief pressure MPa (psi)	8.8 (1,277)	9.8 (1,422)
	Reservoir type	Separate type (plastic)	
	Pressure switch	Equipped	Equipped
Steering gear	Type	Rack and pinion	Rack and pinion
	Stroke ratio (Rack stroke/Steering wheel Maximum turning radius)	49.62	49.62
	Rack stroke mm (in)	131 (5.2)	131 (5.2)

**SERVICE SPECIFICATIONS**

M1372000300717

ITEM		STANDARD VALUE	LIMIT
Steering wheel free play mm (in)	With engine running	–	30 (1.2)
	With engine stopped	10 (0.4) or less	–
Steering angle	Inside wheel	31° 48' ± 2° 00'	–
	Outside wheel (reference)	27° 06'	–
Toe-in mm (in)		0 ± 3 (0 ± 0.12)	–
Tie rod end ball joint breakaway torque N· m (in-lb)		0.5 – 3.5 (4.4 – 31.0)	–
Tie rod swing resistance N (lb) [Tie rod swing torque N· m (in-lb)]		3.6 – 17.6 (0.81 – 3.96) [1.0 – 4.9 (8.9 – 43.3)]	–
Stationary steering effort N (lb) [Fluctuation allowance N (lb)]		35 (7.9) or less [5.9 (1.33) or less]	–
Oil pump pressure MPa (psi)	Oil pump relief pressure	8.3 – 8.8 (1,204 – 1,276) <2.4L engine> 9.3 – 9.8 (1,349 – 1,421) <3.8L engine>	–
	Pressure under no-load conditions	0.8 – 1.0 (116 – 145)	–
	Steering gear retention hydraulic pressure	8.3 – 8.8 (1,204 – 1,276) <2.4L engine> 9.3 – 9.8 (1,349 – 1,421) <3.8L engine>	–
Oil pressure switch operating pressure MPa (psi)	OFF → ON	1.8 – 2.4 (261 – 348)	–
	ON → OFF	0.8 – 1.4 (116 – 203)	–
Steering gear total pinion torque N· m (in-lb) [Change in torque N· m (in-lb)]		0.8 – 1.9 (7.1 – 16.8) [0.7 (6.2) or less]	–
Opening dimension of special tool MB991561 mm (in)		1.9 (0.07)	–
Band crimped width mm (in)		1.4 – 1.8 (0.06 – 0.07)	–

**LUBRICANTS**

M1372000400372

ITEM		SPECIFIED LUBRICANT	QUANTITY dm <sup>3</sup> (qt)
Power steering fluid		GENUINE MITSUBISHI POWER STEERING FLUID	1.2 (1.3)
Gear box	Bearing	GENUINE MITSUBISHI POWER STEERING FLUID	As required
	O-ring		
	Oil seal		
	Special tool (MB991213)		
	Pinion and valve assembly seal ring part		
	Bellows	Silicon grease	As required
Oil pump	Power steering fluid	GENUINE MITSUBISHI POWER STEERING FLUID	0.8 (0.85)

**SEALANT**

M1372000500379

ITEM		SPECIFIED SEALANT
Power steering gear box	End plug	3M™ AAD Part No.8661, 8663, 8672, 8678, 8679 or equivalent
	Rack support cover	

---

## NOTES