

GROUP 42

BODY

CONTENTS

HOOD	42-4	WINDOW GLASS	42-12
BODY DIAGNOSIS	42-4	GENERAL	42-12
INTRODUCTION TO HOOD DIAGNOSIS	42-4	WINDOW GLASS DIAGNOSIS . . .	42-14
HOOD DIAGNOSTIC TROUBLESHOOTING		INTRODUCTION TO WINDOW GLASS	
STRATEGY	42-4	DIAGNOSIS	42-14
SYMPTOM CHART	42-4	WINDOW GLASS DIAGNOSTIC	
SYMPTOM PROCEDURES	42-4	TROUBLESHOOTING STRATEGY	42-14
ON-VEHICLE SERVICE	42-5	WINDOW GLASS DIAGNOSTIC TROUBLE	
ADJUSTMENT OF CLEARANCE AROUND		SYMPTOM CHART	42-14
HOOD	42-5	SYMPTOM PROCEDURES	42-14
ALIGNMENT OF HOOD LATCH AND		SPECIAL TOOL	42-14
STRIKER	42-6	WINDSHIELD	42-15
ADJUSTMENT OF HOOD HEIGHT . . .	42-6	REMOVAL AND INSTALLATION.....	42-15
HOOD	42-7	QUARTER WINDOW GLASS	42-20
REMOVAL AND INSTALLATION	42-7	REMOVAL AND INSTALLATION.....	42-20
FENDER	42-10	LIFTGATE WINDOW GLASS	42-23
REMOVAL AND INSTALLATION	42-10	REMOVAL AND INSTALLATION.....	42-23
FUEL FILLER LID	42-11		
REMOVAL AND INSTALLATION	42-11		
STRUT TOWER BAR			
<3.8L ENGINE>	42-12		
REMOVAL AND INSTALLATION	42-12		

Continued on next page

DOOR	42-26	DOOR ASSEMBLY	42-68
GENERAL DESCRIPTION	42-26	REMOVAL AND INSTALLATION	42-68
CENTRAL DOOR LOCKING SYSTEM DIAGNOSIS	42-26	INSPECTION	42-69
POWER WINDOW DIAGNOSIS ..	42-27	DOOR GLASS AND REGULATOR	42-70
INTRODUCTION TO POWER WINDOW DIAGNOSIS	42-27	REMOVAL AND INSTALLATION	42-70
POWER WINDOW DIAGNOSTIC TROUBLESHOOTING STRATEGY ...	42-27	INSPECTION	42-71
TROUBLE SYMPTOM CHART	42-27	DOOR HANDLE AND LATCH	42-72
SYMPTOM PROCEDURES	42-28	REMOVAL AND INSTALLATION	42-72
DOOR DIAGNOSIS	42-49	INSPECTION	42-75
INTRODUCTION TO GLASS AND DOOR DIAGNOSIS	42-49	WINDOW GLASS RUNCHANNEL AND DOOR OPENING WEATHERSTRIP	42-78
GLASS AND DOOR DIAGNOSTIC TROUBLESHOOTING STRATEGY ...	42-49	REMOVAL AND INSTALLATION	42-78
SYMPTOM CHART	42-50	LIFTGATE	42-80
SYMPTOM PROCEDURES	42-50	LIFTGATE DIAGNOSIS	42-80
HOW TO LOCATE WIND NOISE	42-53	INTRODUCTION TO LIFTGATE DIAGNOSIS	42-80
SPECIAL TOOLS	42-54	LIFTGATE DIAGNOSTIC TROUBLESHOOTING STRATEGY	42-80
ON-VEHICLE SERVICE	42-56	SYMPTOM CHART	42-80
FRONT DOOR FIT ADJUSTMENT	42-56	SYMPTOM PROCEDURES	42-80
DOOR WINDOW GLASS ADJUSTMENT	42-58	SPECIAL TOOLS	42-81
POWER WINDOW TIMER FUNCTION CHECK	42-64	ON-VEHICLE SERVICE	42-82
POWER WINDOW OPERATING CURRENT CHECK	42-64	ADJUSTMENT OF CLEARANCE AROUND LIFTGATE	42-82
POWER WINDOW RELAY CHECK ...	42-64	ALIGNMENT OF LIFTGATE LATCH AND LIFTGATE STRIKER	42-82
POWER WINDOW CHECK	42-65	ADJUSTMENT OF LIFTGATE HEIGHT.	42-83
SHORT STROKE MECHANISM FULLY CLOSED POSITION LEARNING PROCEDURE	42-65	LIFTGATE	42-84
CENTRAL DOOR LOCKING SYSTEM INSPECTION	42-65	REMOVAL AND INSTALLATION	42-84
FORGOTTEN KEY PREVENTION FUNCTION CHECK	42-65	INSPECTION	42-87
DOOR OUTSIDE HANDLE PLAY CHECK	42-66		
DOOR INSIDE HANDLE PLAY CHECK	42-66		

Continued on next page

KEYLESS ENTRY SYSTEM . . .	42-88	ON-VEHICLE SERVICE	42-98
GENERAL DESCRIPTION	42-88	WATER TEST	42-98
KEYLESS ENTRY SYSTEM DIAGNOSIS	42-88	SUNROOF FIT ADJUSTMENT	42-99
SPECIAL TOOL	42-89	SUNROOF CHECK	42-99
ON-VEHICLE SERVICE	42-90	SUNROOF TIMER FUNCTION CHECK	42-99
KEYLESS ENTRY SYSTEM INSPECTION	42-90	ROOF LID GLASS OPERATION	
KEYLESS ENTRY SYSTEM TIMER LOCK FUNCTION INSPECTION	42-90	CURRENT CHECK	42-100
ENABLING/DISABLING THE ANSWERBACK FUNCTION	42-91	SUNROOF OPERATION CHECK	42-100
HOW TO REGISTER SECRET CODE	42-93		
TRANSMITTER	42-96	SUNROOF ASSEMBLY	42-102
DISASSEMBLY AND ASSEMBLY	42-96	REMOVAL AND INSTALLATION	42-102
INSPECTION	42-97	INSPECTION	42-104
SUNROOF ASSEMBLY	42-98	DISASSEMBLY AND ASSEMBLY	42-104
GENERAL DESCRIPTION	42-98	LOOSE PANEL	42-105
SUNROOF DIAGNOSIS	42-98	REMOVAL AND INSTALLATION	42-105
SPECIAL TOOLS	42-98	SPECIFICATIONS	42-107
		FASTENER TIGHTENING SPECIFICATIONS	42-107
		SERVICE SPECIFICATIONS	42-108
		SEALANT AND ADHESIVES	42-108
		COMPONENT IDENTIFICATIONS	42-108

HOOD

BODY DIAGNOSIS

INTRODUCTION TO HOOD DIAGNOSIS

Wind noise at the hood may be caused by improper hood adjustment.

M1421005800415

HOOD DIAGNOSTIC TROUBLESHOOTING STRATEGY

Use these steps to plan your diagnostic strategy. If you follow them carefully, you will be sure that you have exhausted most of the possible ways to find a hood fault.

1. Gather information from the customer.

2. Verify that the condition described by the customer exists.
3. Find the malfunction by following the Symptom Chart.
4. Verify malfunction is eliminated.

M1421005900371

SYMPTOM CHART

M1421006000412

SYMPTOM	INSPECTION PROCEDURE	REFERENCE PAGE
Difficult locking and unlocking	1	P.42-4
Uneven body clearance	2	P.42-5
Uneven height	3	P.42-5

SYMPTOM PROCEDURES

INSPECTION PROCEDURE 1: Difficult Locking and Unlocking

DIAGNOSIS

STEP 1. Check that the release cable is routed correctly.

Q: Is the release cable routed correctly?

YES : Go to Step 2.

NO : Re-route the release cable. Then go to Step 4.

STEP 2. Check the engagement of the hood latch and hood striker.

Q: Are the hood latch and hood striker engaged correctly?

YES : Go to Step 3.

NO : Adjust the hood latch (Refer to P.42-6). Then go to Step 4.

STEP 3. Check for proper lubrication of release cable.

Q: Is the release cable properly lubricated?

YES : Go to Step 4.

NO : Lubricate, then go to Step 4.

STEP 4. Retest the system.

Q: Does the hood lock operate easily?

YES : The procedure is complete.

NO : Return to Step 1.

INSPECTION PROCEDURE 2: Uneven Body Clearance

DIAGNOSIS

STEP 1. Check the clearance around the hood.

Q: Is the clearance around the hood even?

YES : Go to Step 2.

NO : Adjust the hood (Refer to [P.42-5](#)). Then go to Step 2.

STEP 2. Retest the system.

Q: Are the clearances between body panels even?

YES : The procedure is complete.

NO : Return to Step 1.

INSPECTION PROCEDURE 3: Uneven Height

DIAGNOSIS

STEP 1. Check the hood damper height.

Q: Is the hood damper height proper?

YES : Go to Step 2.

NO : Adjust the hood damper (Refer to [P.42-6](#)). Then go to Step2.

STEP 2. Retest the system.

Q: Are the hood and body height even?

YES : The procedure is complete.

NO : Return to Step 1.

ON-VEHICLE SERVICE

ADJUSTMENT OF CLEARANCE AROUND HOOD

M1421007200248

Detach the fender hole cover (Refer to GROUP 51, Windshield Wiper [P.51-13](#)). Then loosen the hood hinge mounting nuts and bolts as shown, and adjust the hood by moving it until the clearance around it is even.

NOTE:

If the hood hinge mounting bolt washers are welded, grind off the welding according to the procedure below beforehand.

1. Remove the hood hinge (Refer [P.42-7](#)).
2. Use a chisel or grinder to release the hood hinge mounting bolt washer, which is welded to the hood hinge.
3. On completion, paint the affected area with a suitable touch-up brush to prevent corrosion.
4. Install the hood hinge (Refer [P.42-7](#)).

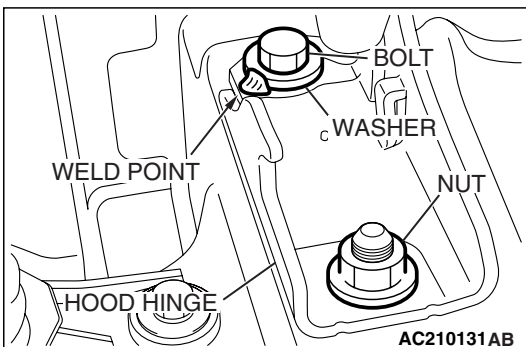
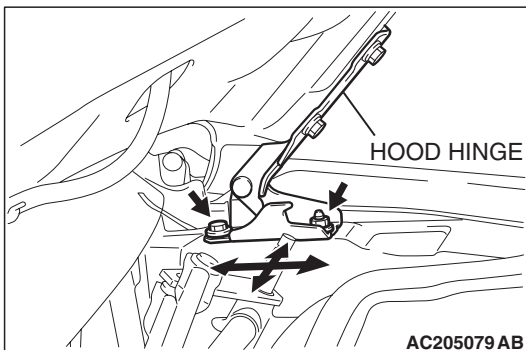

ALIGNMENT OF HOOD LATCH AND STRIKER

M1421008500037

Note the routing of the hood release cable, and then loosen the hood latch mounting bolts. Then align the latch with the striker by moving the hood latch. After alignment, ensure that the hood can be locked and unlocked correctly.

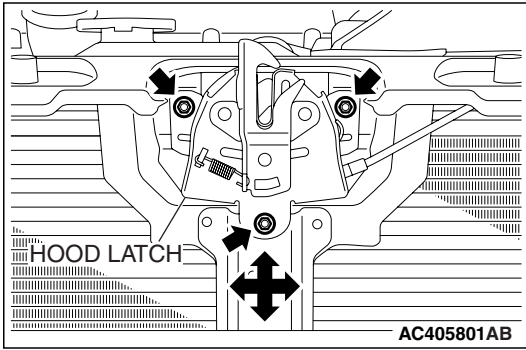

ADJUSTMENT OF HOOD HEIGHT

M1421007400264

Turn the hood damper until its height is as shown. If the hood height is still not even at left and right sides, turn the hood damper further until the hood height is even. The hood damper height is altered by roughly 3mm (0.1 inch) when turning the hood damper one rotation.

NOTE: If a rattling noise (clacking noise) is caused by the vibration of the hood while driving, adjust the hood damper height so that the hood damper contacts the hood securely.

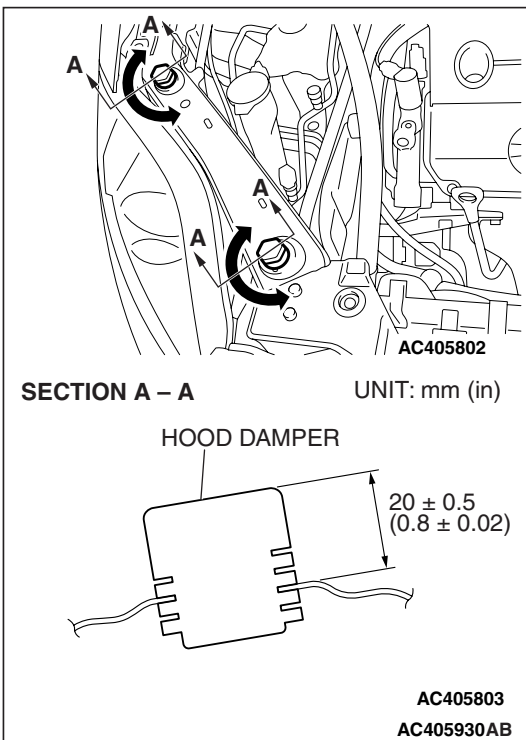

HOOD

REMOVAL AND INSTALLATION

M1421001600679

Post-installation Operation

- Adjustment of Clearance Around Hood (Refer to P.42-5).
- Alignment of Hood Latch and Striker (Refer to P.42-6).
- Hood Height Adjustment (Refer to P.42-6).

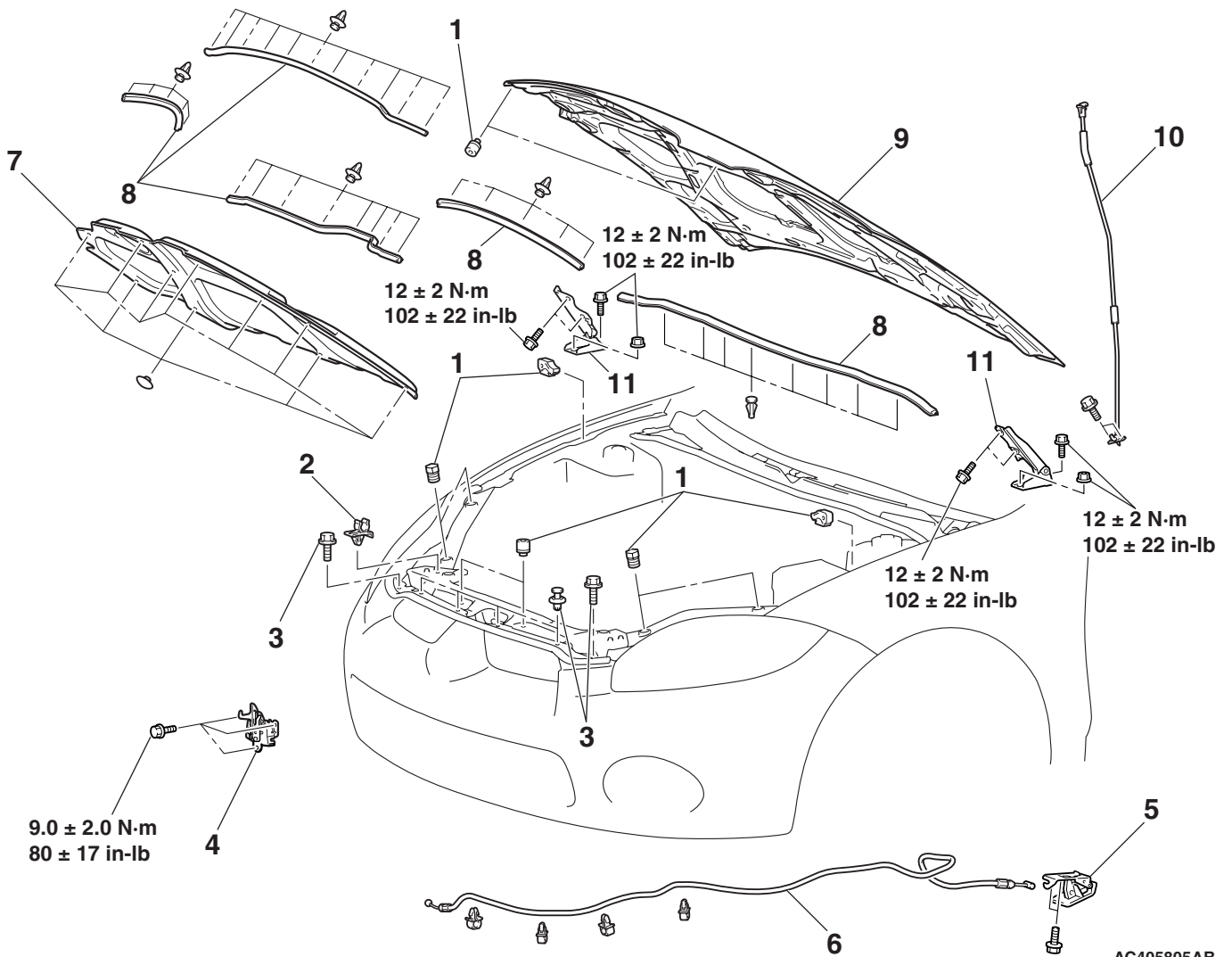
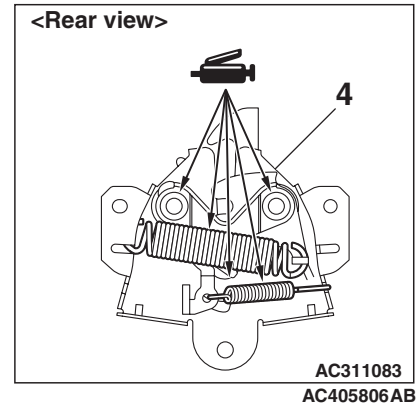
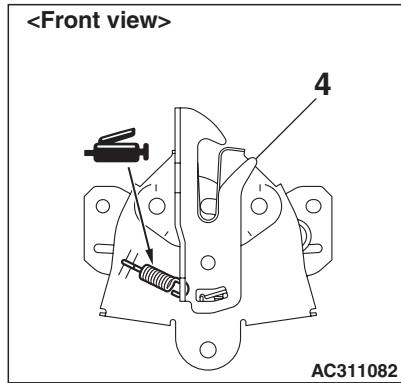
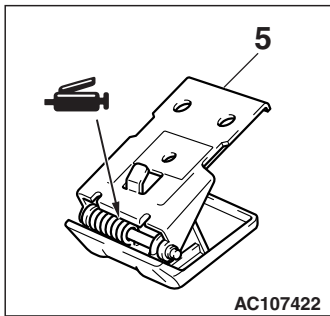

TSB Revision

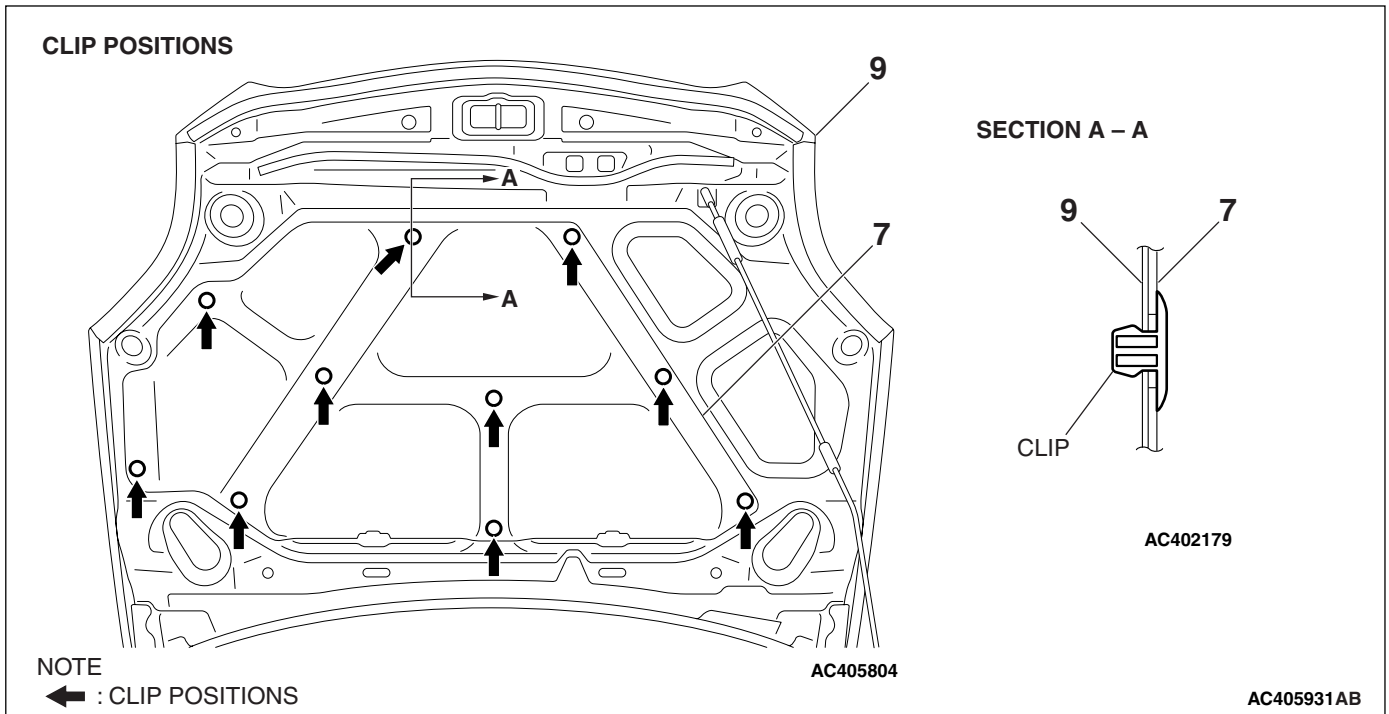

REMOVAL

1. HOOD DAMPER
2. CLIP

**HOOD LATCH AND HOOD LOCK
RELEASE CABLE REMOVAL
STEPS**

3. FRONT BUMPER MOUNTING
BOLTS AND CLIPS
4. HOOD LATCH
 - SPLASH SHIELD (REFER TO [P.42-10.](#))
 - FRONT BUMPER ASSEMBLY (REFER TO GROUP 51, FRONT BUMPER AND RADIATOR GRILLE [P.51-2.](#))
 - HEADLIGHT ASSEMBLY <LH> (REFER TO GROUP 54A, HEADLIGHT AND FRONT COMBINATION LIGHT [P.54A-137.](#))

<<A>>

**HOOD LATCH AND HOOD LOCK
RELEASE CABLE REMOVAL
STEPS (Continued)**

5. HOOD LOCK RELEASE HANDLE
 6. HOOD LOCK RELEASE CABLE
- HOOD AND HOOD HINGE
REMOVAL STEPS**
7. HOOD INSULATOR
 8. HOOD WEATHERSTRIP
 - WINDSHIELD WASHER HOSE, WINDSHIELD WASHER NOZZLE (REFER TO GROUP 51, WINDSHIELD WASHER [P.51-18.](#))
 9. HOOD
 10. HOOD SUPPORT ROD
 - FENDER HOLE COVER (REFER TO GROUP 51, WINDSHIELD WIPER [P.51-13.](#))
 11. HOOD HINGE

REMOVAL SERVICE POINT

<<A>> HOOD LOCK RELEASE CABLE REMOVAL

Release the grommet as shown, and pull out the hood lock release cable in the arrow direction (passenger compartment side).

NOTE: If you attempt to pull out the hood lock release cable in the opposite direction, the end of the hood lock release cable will engage the grommet and prevent cable removal.

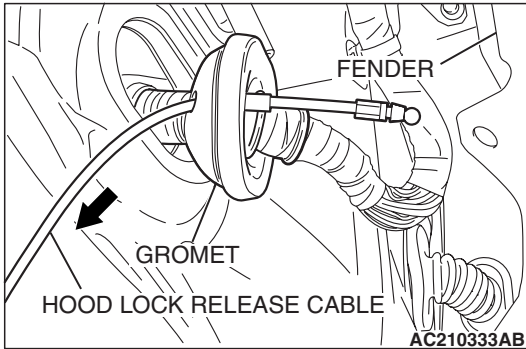

FENDER

REMOVAL AND INSTALLATION

M1421001900681

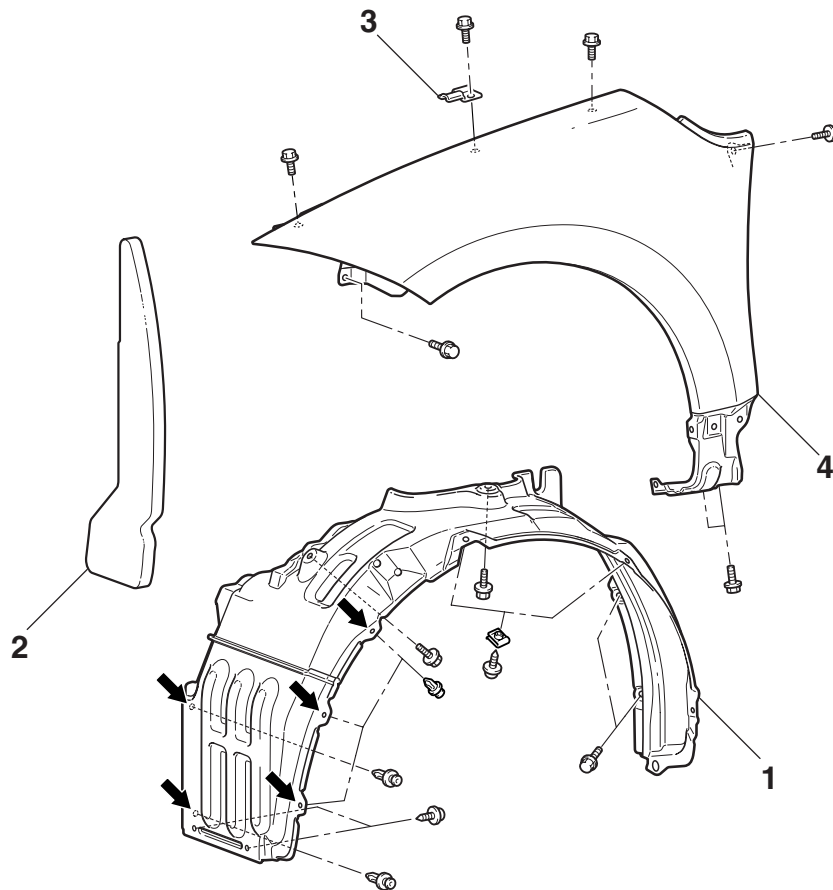

NOTE

← : CLIP POSITIONS

REMOVAL STEPS

- FRONT SIDE AIR DAM (REFER TO GROUP 51, SIDE AIR DAM P.51-7.)
- 1. SPLASH SHIELD
- 2. FRONT PILLAR PAD
- FRONT BUMPER ASSEMBLY (REFER TO GROUP 51, FRONT BUMPER AND RADIATOR GRILLE P.51-2.)

AC405800AB

REMOVAL STEPS (Continued)

- HEADLIGHT ASSEMBLY REMOVAL AND INSTALLATION (REFER TO GROUP 54A, HEADLIGHT AND FRONT COMBINATION LIGHT P.54A-137.)
- FRONT DELTA GARNISH (REFER TO GROUP 51, GARNISHES AND MOLDING P.51-5.)
- 3. HOOD DAMPER BRACKET
- 4. FRONT FENDER

FUEL FILLER LID

REMOVAL AND INSTALLATION

M1421002500482

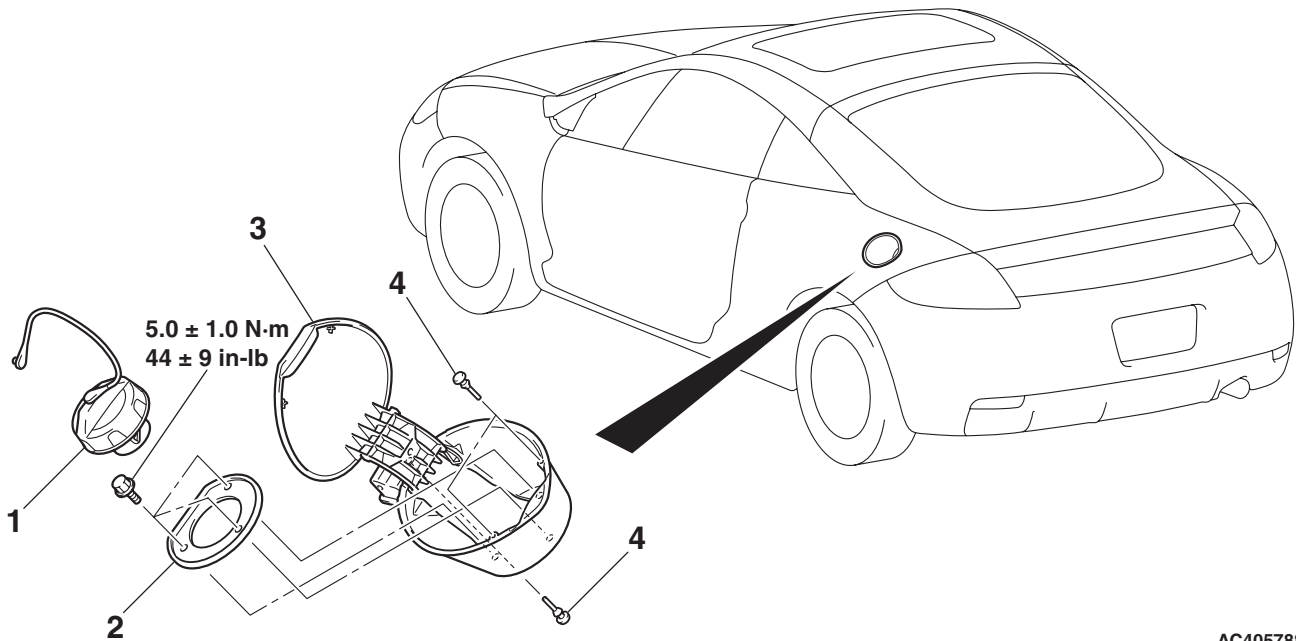

AC405788AB

REMOVAL STEPS

1. FUEL FILLER CAP
2. FUEL FILLER NECK REINFORCEMENT PLATE

REMOVAL STEPS (Continued)

3. FUEL FILLER LID
4. FUEL FILLER LID DAMPER

STRUT TOWER BAR <3.8L ENGINE>**REMOVAL AND INSTALLATION**

M1421005600176

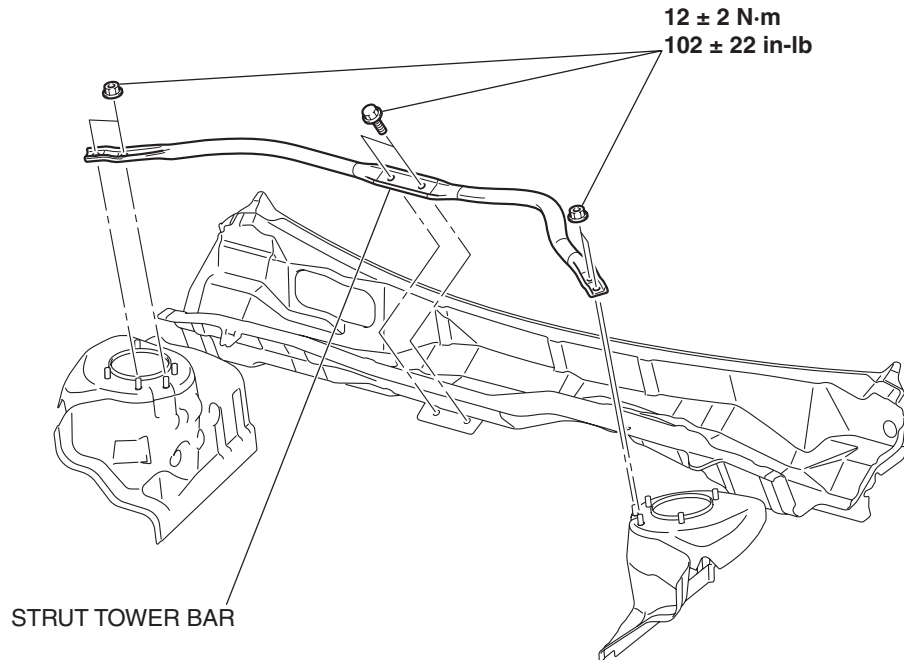

AC404850AB

WINDOW GLASS**GENERAL**

M1422000100588

The windshield, quarter window glass and liftgate window glass are attached by an urethane-base adhesive to the window frame. This adhesive provides improved glass holding and sealing, and also gives body openings a greater structural strength.

ITEMS

ITEM	APPLICATION	QUANTITY
Wire (diameter × length)	For cutting adhesive	Five pieces of wire 0.6 mm × 1 m (0.02 in × 3.3 ft)
Glass adhesive knife	For cutting adhesive	One
Sealant gun	For adhesive application	One
Wiping shop towels	-	As required
Sealer	For prevention of water and wind leaks after adhesive application	As required
3M AAD™ Part No. 8906 or equivalent	For cleaning	As required
Glass holder MB990480	For securing of window glass	Two

WINDOW GLASS INSTALLATION

⚠ CAUTION

Do not apply primer on the adhesion surface, as adhesion may be reduced.

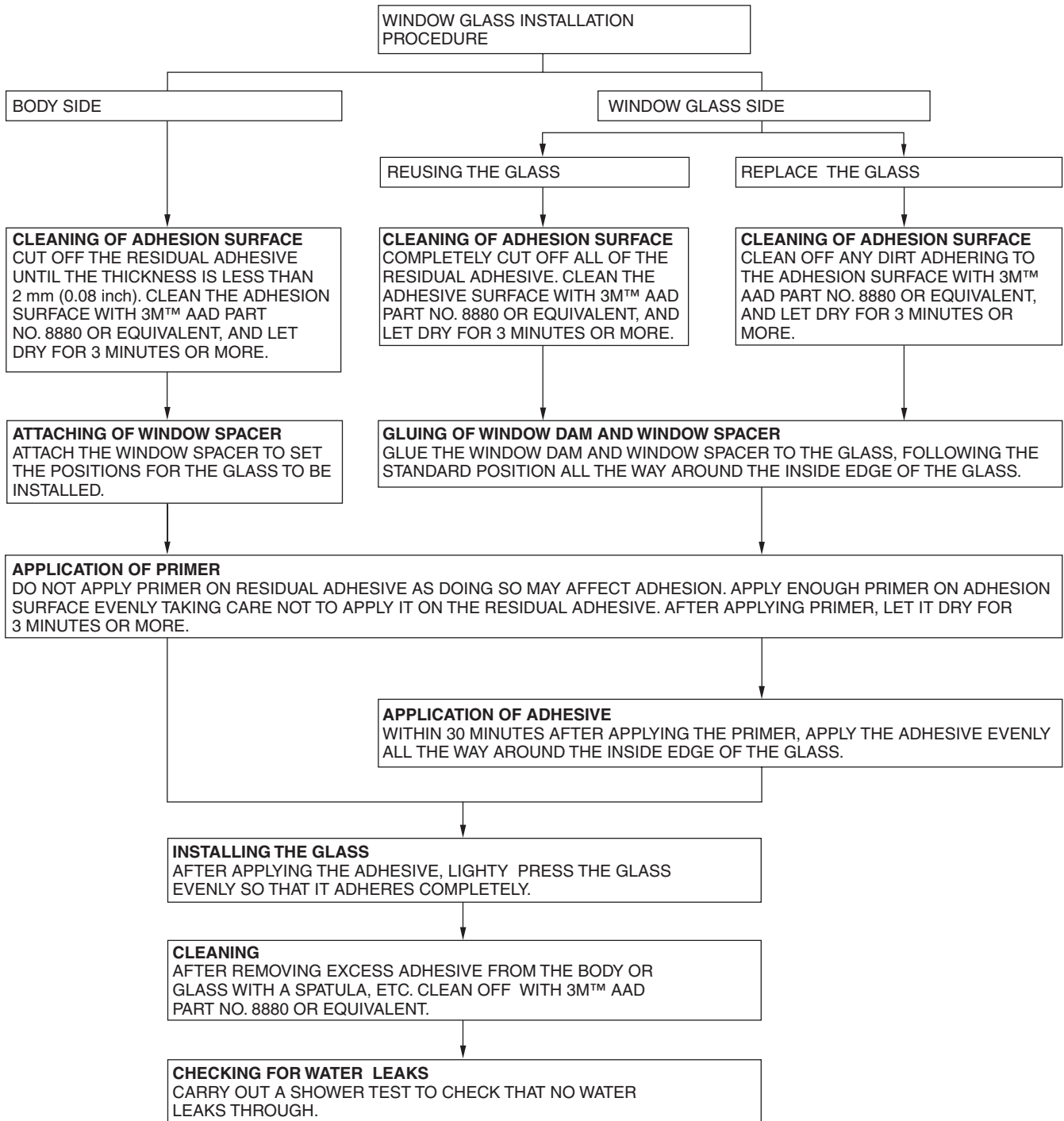

AC306636AF

WINDOW GLASS DIAGNOSIS**INTRODUCTION TO WINDOW GLASS DIAGNOSIS**

M1422006700287

If water emerges from the following points, there is a problem in the seal or body flange.

- Windshield

- Quarter window glass
- Liftgate window glass

WINDOW GLASS DIAGNOSTIC TROUBLESHOOTING STRATEGY

M1422006800273

Use these steps to plan your diagnostic strategy. If you follow them carefully, you will be sure that you have exhausted most of the possible ways to find a window glass fault.

1. Gather information from the customer.

2. Verify that the condition described by the customer exists.
3. Find the malfunction by following the Symptom Chart.
4. Verify malfunction is eliminated.

WINDOW GLASS DIAGNOSTIC TROUBLE SYMPTOM CHART

M1422006900333

SYMPTOM	INSPECTION PROCEDURE	REFERENCE PAGE
Water leak through windshield	1	P.42-14
Water leak through quarter window glass		
Water leak through liftgate window glass		

SYMPTOM PROCEDURES**INSPECTION PROCEDURE 1: Water Leak Through Windshield/Water Leak Through Quarter Window Glass/Water Leak Through Liftgate Window Glass****DIAGNOSIS****STEP 1. Check if the seal is faulty.**

Q: Is the seal faulty?

- YES :** Repair the seal, then go to Step 3.
NO : Go to Step 2.

STEP 2. Check if the body flange is deformed.

Q: Is the body flange deformed?

- YES :** Replace the body flange, then go to Step 3.
NO : Go to Step 3.

STEP 3. Retest the system.

Q: Is any water leaking?

- YES :** Return to Step 1.
NO : This diagnosis complete.

SPECIAL TOOL

M142200600301

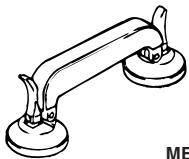
TOOL	TOOL NUMBER AND NAME	SUPERSESSION	APPLICATION
 <p>MB990480</p>	MB990480 Glass holder	General service tool	Removal and installation of window glass

WINDSHIELD

REMOVAL AND INSTALLATION

M1422001000603

Pre-removal and Post-installation Operation

- Front Deck Garnish Removal and Installation (Refer to GROUP 51, Windshield Wiper and Washer P.51-13).
- Front Pillar Garnish and Roof Drip Molding Removal and Installation (Refer to GROUP 51, Garnish and Molding P.51-5).
- Front Pillar Trim Removal and Installation (Refer to GROUP 52A, Trims P.52A-31).
- Inside Rear View Mirror Removal and Installation (Refer to GROUP 52A, Inside Rear View Mirror P.52A-38).

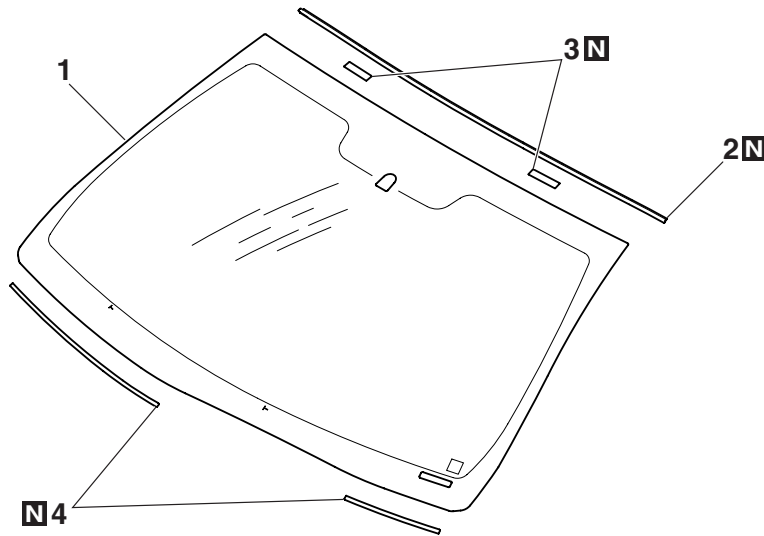

AC405812 AB

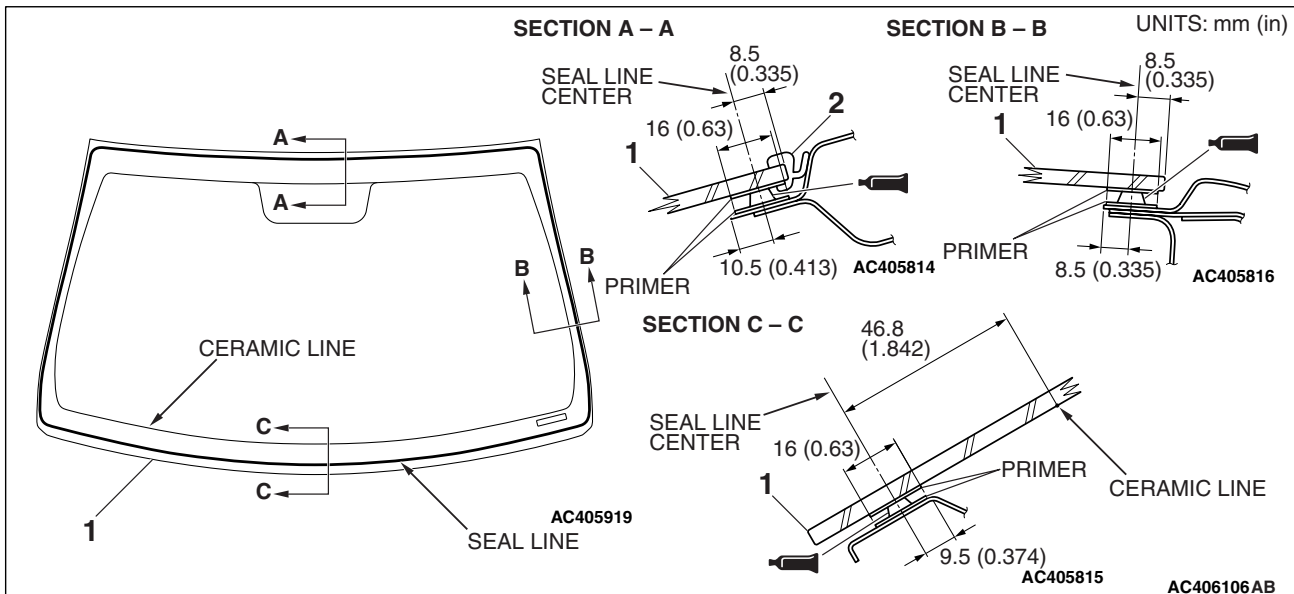

AC406106 AB

ADHESIVE: 3M™ AAD PART NO. 8609 SUPER FAST URETHANE AND 3M™ AAD PART NO. 8608 SUPER FAST URETHANE PRIMER OR EQUIVALENT

REMOVAL STEPS

- <<A>> >>B<< 1. WINDSHIELD
 >>A<< 2. WINDSHIELD MOLDING
 >>A<< 3. GLASS STOPPER
 >>A<< 4. WINDSHIELD SPACER

Required Special Tool:

- MB990480: Glass Holder

REMOVAL SERVICE POINT

<<A>> WINDSHIELD REMOVAL

1. To protect the body (paint surface), apply cloth tape to all body areas around the installed windshield.
2. Make mating marks on the windshield and body.
3. Using piano wire.
 - (1) Using a sharp-point drill, make a hole in the windshield adhesive.
 - (2) Pass the piano wire from the inside of the vehicle through the hole.

⚠ CAUTION

Do not let the piano wire touch the edge of the windshield.

- (3) Pull the piano wire alternately from the inside and outside along the windshield to cut the adhesive.

⚠ CAUTION

Inserting the glass adhesive knife too deeply into windshield adhesive may damage windshield.

4. Using glass adhesive knife

Keep glass adhesive knife at right angles with the windshield edge, and put the blade at windshield edge and surface. Then cut away adhesive along the windshield edge.

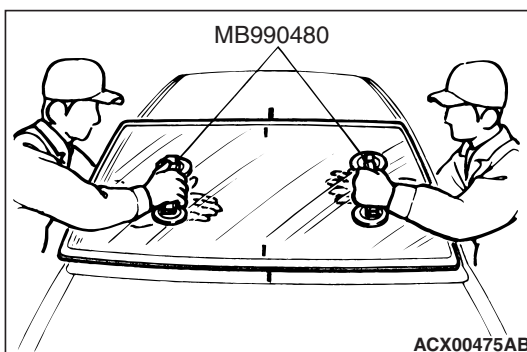
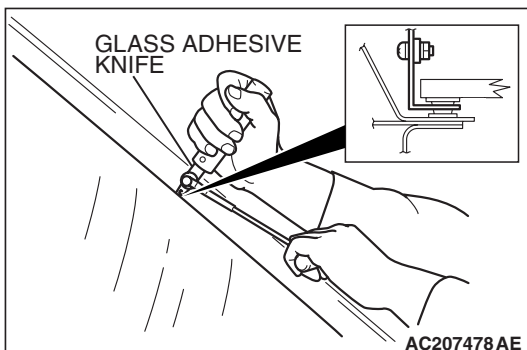
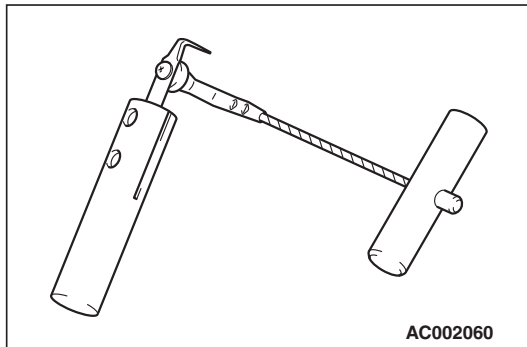
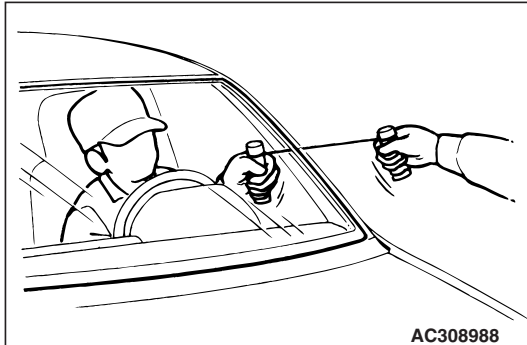

5. Use special tool MB990480 to remove the windshield.

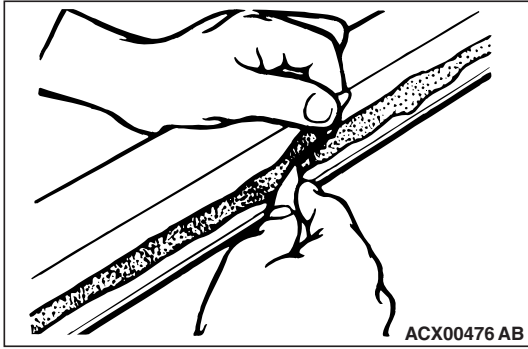

⚠ CAUTION

- Be careful not to remove more adhesive than is necessary.
 - Be careful also not to damage the paint on the body surface with the knife. If the paint is damaged, repair the damaged area with touch-up paint.
6. Use a knife to cut away the remaining adhesive so that the thickness is within 2 mm (0.08 inch) around the entire circumference of the body flange.
 7. Finish the flange surfaces so that they are smooth.

⚠ CAUTION

Allow the cleaned area to dry for at least three minutes. Do not touch any surface that has been cleaned.

8. When reusing the windshield, remove the adhesive still adhering to the windshield, and clean with 3M™ AAD Part number 8880 or equivalent.
9. Clean the body side in the same way.

INSTALLATION SERVICE POINTS

>>A<< WINDSHIELD SPACER/GLASS STOPPER/WINDSHIELD MOLDING INSTALLATION

⚠ CAUTION

Leave the degreased parts for 3 or more minutes to dry well, before starting on the next step. Do not touch the degreased parts.

1. Use 3M™ AAD Part number 8880 or equivalent to degrease the inside and outside of the windshield and the body flanges.

WINDSHIELD SPACER AND GLASS STOPPER INSTALLATION POSITION

UNITS: mm (in)

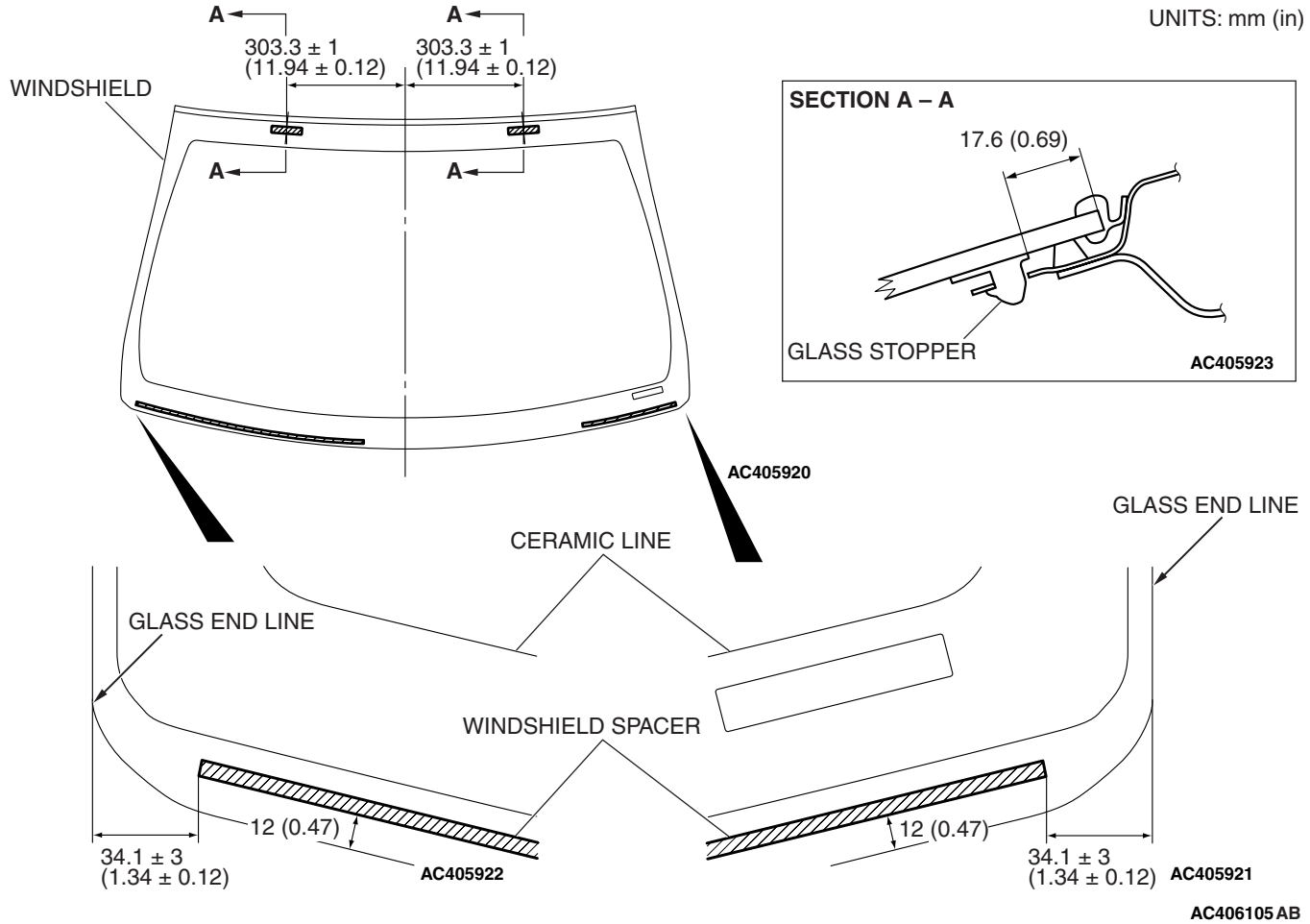

2. Install the windshield spacer and glass stoppers to the specified positions so that there are no adrift or warped surfaces inside the windshield.
3. Install the windshield moldings to the windshield.

>>B<<WINDSHIELD INSTALLATION

1. When replacing the windshield, temporarily set the windshield against the body, and place a mating mark on the windshield and body.

⚠ CAUTION

- The primer strengthens the adhesive, so be sure to apply it evenly around the entire circumference. However, a too thick application will weaken the adhesive.
 - Do not touch the coated surface.
 - Do not apply the primer on the remaining adhesive because of weakening the adhesive.
2. Soak a sponge in the primer, and apply evenly to the windshield and the body in the specified places.
 3. Allow the windshield to dry for at least three minutes after applying primer.

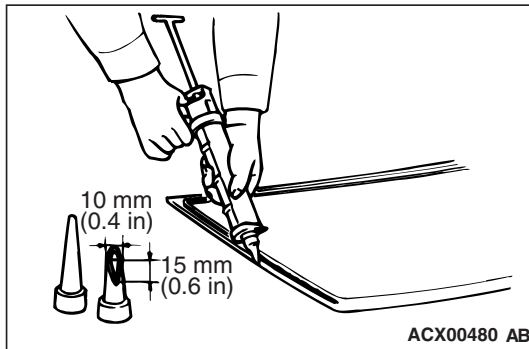

4. Fill a sealant gun with adhesive. Then apply the adhesive evenly around the windshield within 30 minutes after applying the primer.

NOTE: Cut the tip of the sealant gun nozzle into a V shape to simplify adhesive application.

5. Align the mating marks on the windshield and the body, and lightly press the windshield evenly so that it adheres completely.
6. Use a spatula or similar tool to remove any excessive adhesive. Clean the surface with 3M™ AAD Part number 8880 or equivalent. Avoid moving the vehicle until the adhesive sets.

⚠ CAUTION

- **Do not move the vehicle unless absolutely necessary.**
 - **When testing for water leakage, do not apply strong water pressure.**
7. Wait 30 minutes or more, and then test for water leakage.

**QUARTER WINDOW GLASS
REMOVAL AND INSTALLATION**

M1422002500496

Pre-removal and Post-installation Operation

- Center Pillar Upper Trim and Rear pillar Trim Removal and Installation (Refer to GROUP 52A, Trims P.52A-31).
- Door Window Weatherstrip Holder Removal and Installation (Refer to P.42-78).

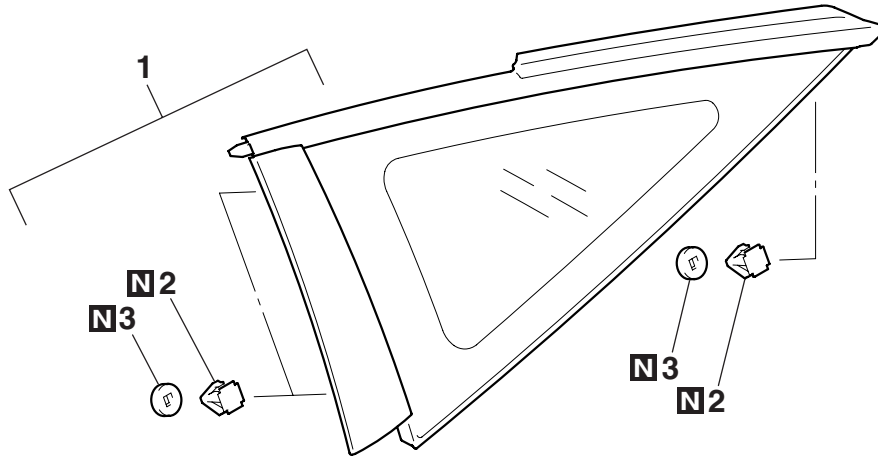

AC405813AB

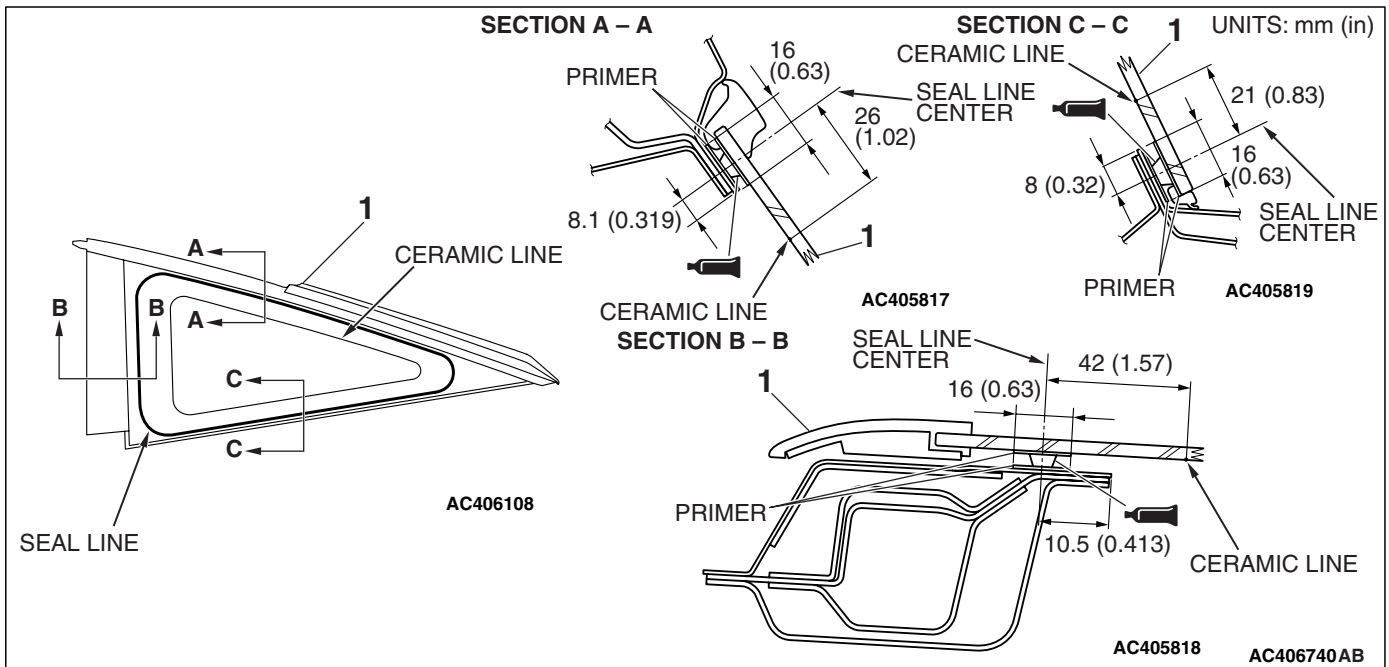

ADHESIVE: 3M™ AAD PART NO. 8609 SUPER FAST URETHANE AND 3M™ AAD PART NO. 8608 SUPER FAST URETHANE PRIMER OR EQUIVALENT

REMOVAL STEPS

- <<A>> >>B<< 1. QUARTER WINDOW GLASS ASSEMBLY
- >>A<< 2. CLIP
- >>A<< 3. GASKET

Required Special Tool:

- MB990480: Glass Holder

REMOVAL SERVICE POINT

<<A>> QUARTER WINDOW GLASS ASSEMBLY
REMOVAL

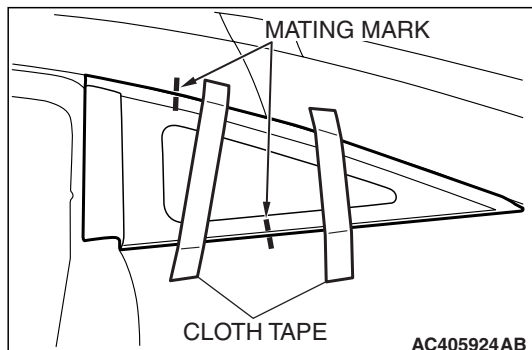

1. Make mating marks on the vehicle body and the quarter window glass, and hold the glass with cloth tape to prevent it from dropping.

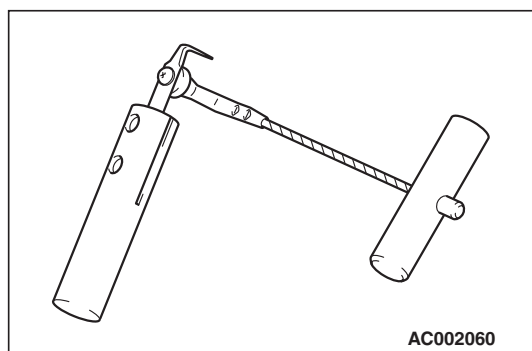

2. Use glass adhesive knife to cut away adhesive.

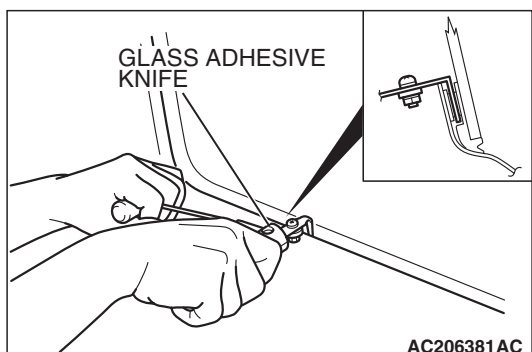

- CAUTION**
Inserting the adhesive knife too deeply into windshield adhesive may damage quarter window glass.
3. Keep the glass adhesive knife at right angles with body flange (from inside the vehicle), and put the blade at body flange. Then cut away adhesive along the body flange.

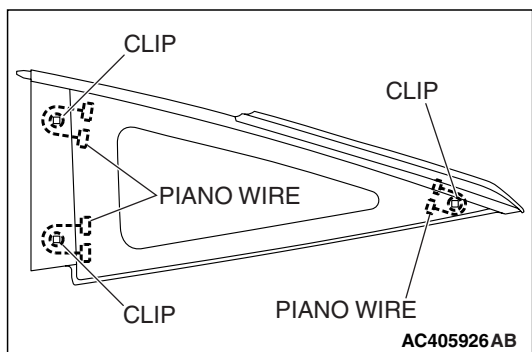

4. Separate the clips by using a piano wire.

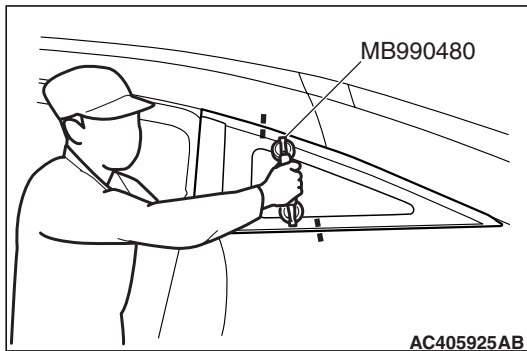

AC405925AB

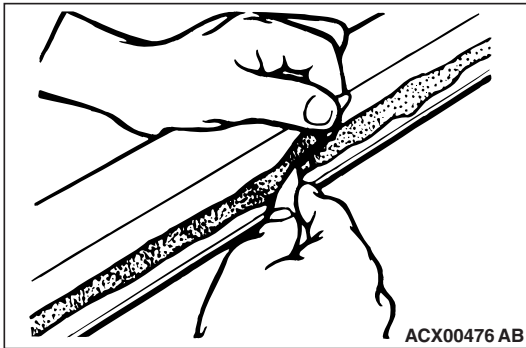

ACX00476 AB

5. Use special tool MB990480 to remove the quarter window glass.

⚠ CAUTION

- Be careful not to remove more adhesive than is necessary.
- Be careful also not to damage the paint on the body surface with the knife. If the paint is damaged, repair the damaged area with touch-up paint.

6. Use a knife to cut away the remaining adhesive so that the thickness is within 2 mm (0.08 inch) around the entire circumference of the body flange.
7. Finish the flange surfaces so that they are smooth.

⚠ CAUTION

Allow the cleaned area to dry for at least three minutes. Do not touch any surface that has been cleaned.

8. When reusing the quarter window glass, remove the adhesive still adhering to the quarter window glass, and clean with 3M™ AAD Part number 8880 or equivalent.
9. Clean the body side in the same way.

INSTALLATION SERVICE POINTS

>>A<< GASKET/CLIP INSTALLATION

Carry out the following procedure to re-install quarter window glass.

⚠ CAUTION

Remember to install the gasket.

1. Fit clips into body.
2. Cut away clip fitting convex on quarter window glass.

NOTE: Convex gets broken when quarter window glass is removed.

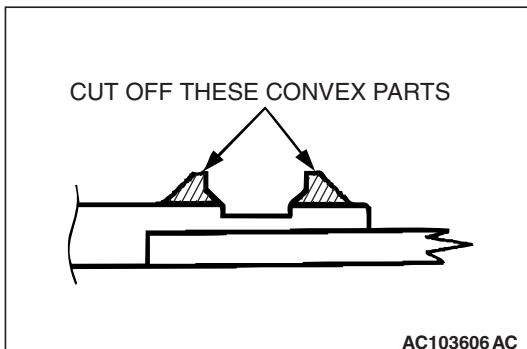

AC103606 AC

>>B<< QUARTER WINDOW GLASS ASSEMBLY INSTALLATION

⚠ CAUTION

Leave the degreased parts for 3 or more minutes to dry well, before starting on the next step. Do not touch the degreased parts.

1. Use 3M™ AAD Part number 8880 or equivalent to degrease the inside and outside of the quarter window glass and the body flanges.
2. Install the quarter window glass using the same procedure as for the windshield installation (Refer to [P.42-15](#)).

**LIFTGATE WINDOW GLASS
REMOVAL AND INSTALLATION**

M1422003700459

Pro-removal and Post-installation Operation

- Liftgate Trim Assembly Removal and Installation (Refer to GROUP 52A, Liftgate Trim P.52A-36).
- Rear Wiper Arm and Blade Assembly Removal and Installation (Refer to GROUP 51, Rear Wiper and Washer P.51-21).

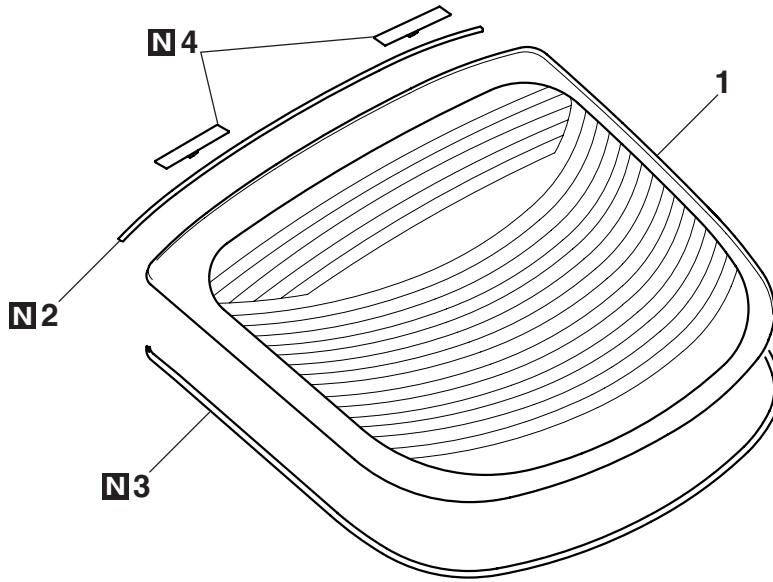

AC406089AB

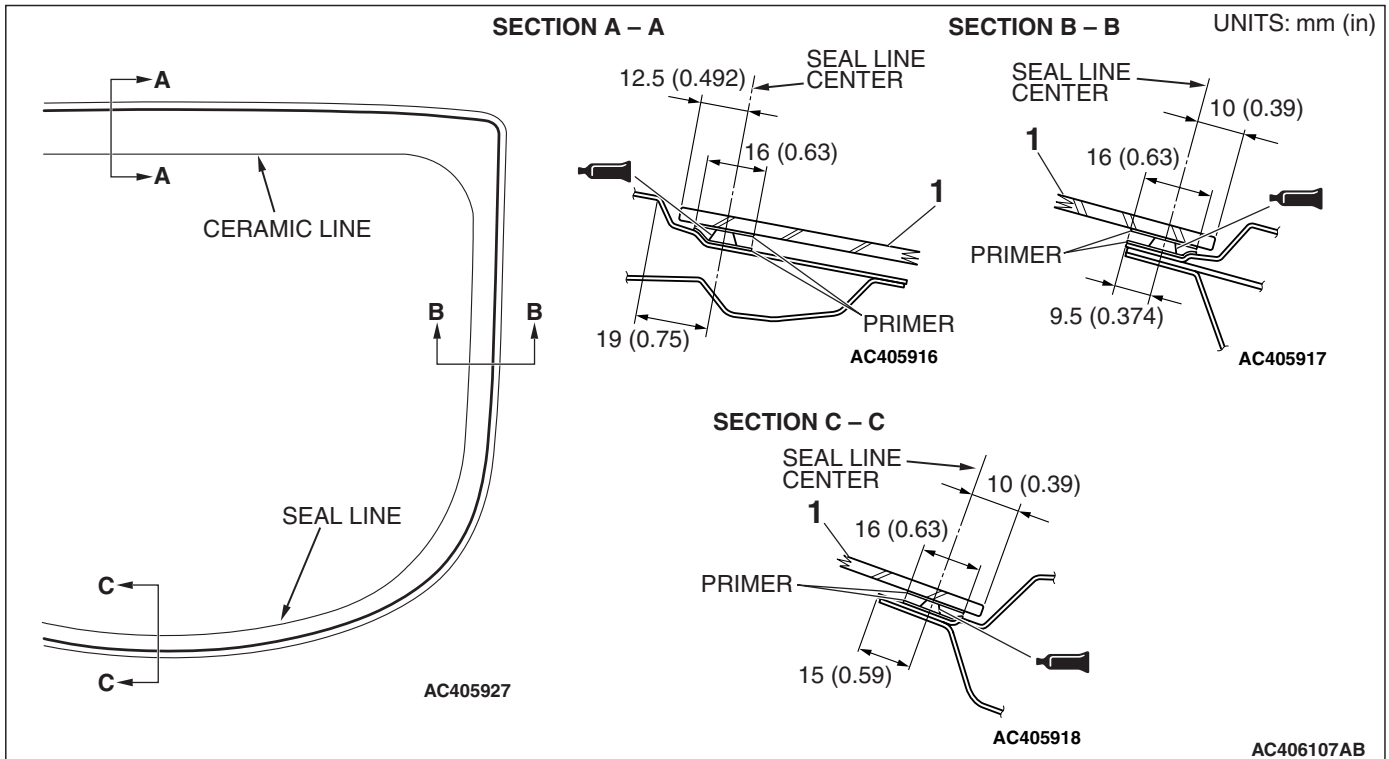

AC406107AB

ADHESIVE: 3M™ AAD PART NO. 8609 SUPER FAST URETHANE AND 3M™ AAD PART NO. 8608 SUPER FAST URETHANE PRIMER OR EQUIVALENT

REMOVAL STEPS

- <<A>> >>B<< 1. LIFTGATE WINDOW GLASS
>>A<< 2. UPPER MOLDING
>>A<< 3. LOWER MOLDING
>>A<< 4. GLASS STOPPER

Required Special Tool:

- MB990480: Glass Holder

REMOVAL SERVICE POINT**<<A>> LIFTGATE WINDOW GLASS REMOVAL**

Remove the liftgate window glass in the same manner as the windshield (Refer to [P.42-15](#)).

NOTE: Use a piano wire to remove the liftgate window glass.

INSTALLATION SERVICE POINTS**>>A<< GLASS STOPPER/LOWER MOLDING/UPPER MOLDING INSTALLATION**** CAUTION**

Before the next job, leave the degreased parts for 3 minutes or more to dry. Do not touch the degreased parts.

1. Use 3M™ AAD Part number 8880 or equivalent to degrease the inside and outside of the liftgate window glass and the liftgate flanges.

GLASS STOPPER AND MOLDING INSTALLATION POSITION

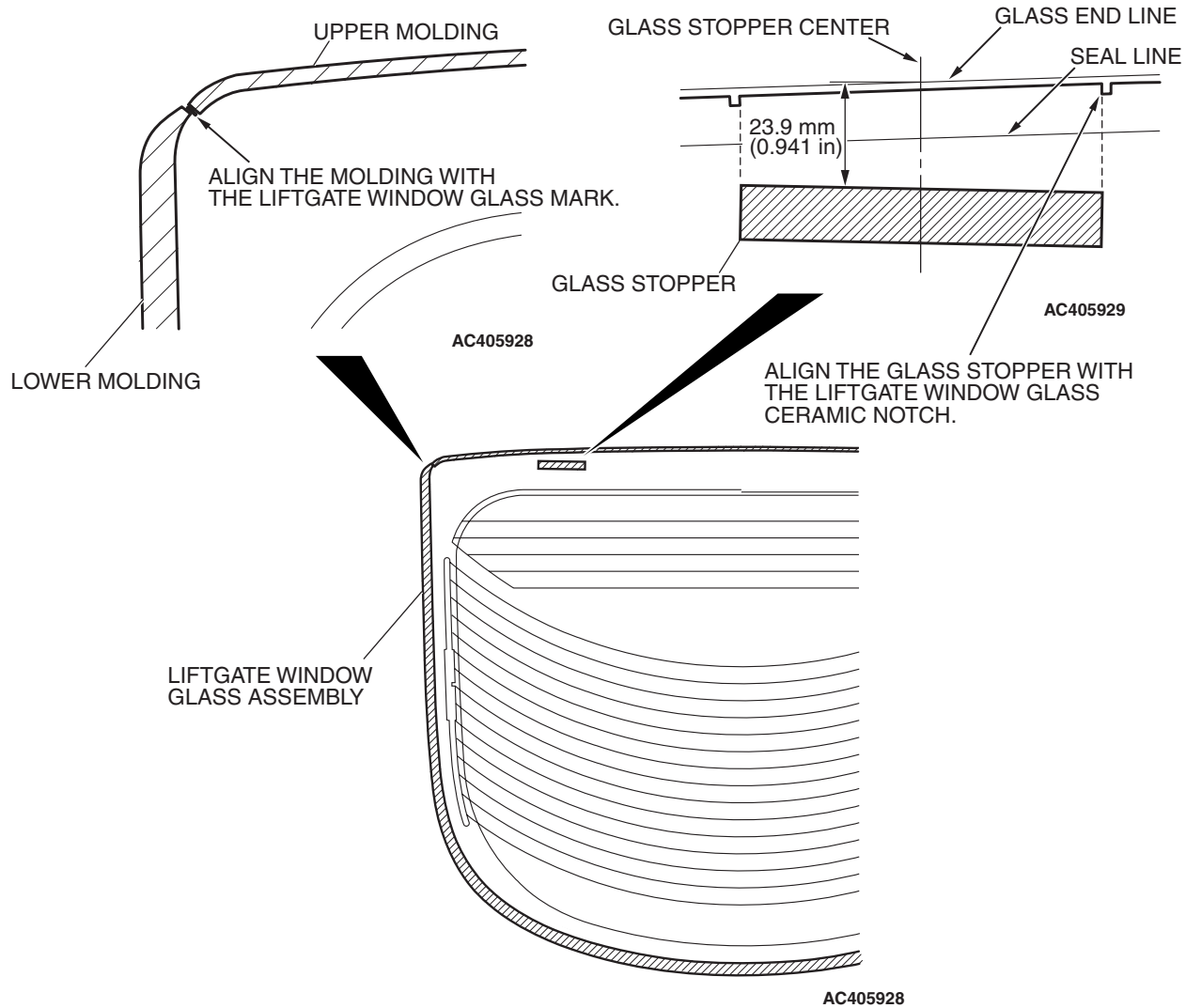

2. Assemble the glass stopper, lower molding and upper molding to specified positions on the liftgate window glass.

**>>B<< LIFTGATE WINDOW GLASS
INSTALLATION**

Install the liftgate window glass in the same manner as the windshield (Refer to [P.42-15](#)).

DOOR

GENERAL DESCRIPTION

OPERATION

CENTRAL DOOR LOCKING SYSTEM

The central door locking system operates the door lock actuator to lock or unlock the doors using the door lock switch built into the front power window (main or sub) switch or key cylinder. The system has the following operations and features:

- All doors can be locked using the door lock switch built into the front power window (main or sub <RH>) switch.
- Insert the key into the driver's key cylinder and turn once to the unlock side to unlock the driver's door. Turn the key once again to the unlock side to unlock all doors and liftgate.
- The key reminder function automatically unlocks all doors when door lock operation is performed and the front doors are opened while the key is inserted into the ignition switch.

POWER WINDOWS

When the power window (main or sub) switch is operated, the door windows will open or close. This system has the following operations and features:

- A power window lock switch on the power window main switch prevents the door window glass from opening/closing with the front passenger's power window sub switch.

M1423000100343

- The power window of the door window glass can be opened/closed for 30 seconds with the timer function after the ignition switch is turned OFF. (The timer expires if the front door <LH or RH> is opened when the timer is in operation).
- The power window main switch contains a one-touch down switch that will automatically open the driver's side door window only.

SHORT STROKE MECHANISM

- If the door outside handle or the door inside handle is operated when the door is closed and the door window glass is fully closed, or when the door is closed and the door window glass is open by less than 10 ± 5 mm (0.39 ± 0.197 inch), the door window glass will be lowered by 10 ± 5 mm (0.39 ± 0.197 inch).
- If the door is closed when the door is open and the door window glass is open by 10 ± 5 mm (0.39 ± 0.197 inch) or less, the door window glass will be fully closed.
- The short stroke mechanism does not work when the door window glass is already lowered 10 ± 5 mm (0.39 ± 0.197 inch) or more from the fully closed position.

CENTRAL DOOR LOCKING SYSTEM DIAGNOSIS

M1427000700284

The central door locking system is controlled by the Simplified Wiring System (SWS). Refer to GROUP 54B, Diagnosis P.54B-57.

POWER WINDOW DIAGNOSIS

INTRODUCTION TO POWER WINDOW DIAGNOSIS

M1429002600160

The power window is controlled by the Simplified Wiring System (SWS). Refer to GROUP 54B, Diagnosis P.54B-57.

SHORT STROKE MECHANISM

- If the door outside handle or the door inside handle is operated when the door is closed and the door window glass is fully closed, or when the door is closed and the door window glass is open by less than 10 ± 5 mm (0.39 ± 0.197 inch), the door window glass will be lowered by 10 ± 5 mm (0.39 ± 0.197 inch).

- If the door is closed when the door is open and the door window glass is open by 10 ± 5 mm (0.39 ± 0.197 inch) or less, the door window glass will be fully closed.
- The short stroke mechanism does not work when the door window glass is already lowered 10 ± 5 mm (0.39 ± 0.197 inch) or more from the fully closed position.

If the following types of symptom occur, there may be a fault.

- The short stroke mechanism does not work.

POWER WINDOW DIAGNOSTIC TROUBLESHOOTING STRATEGY

M1429002700178

Use these steps to plan your diagnostic strategy. If you follow them carefully, you will be sure that you have exhausted most of the possible ways to find a power windows fault.

1. Gather information from customer.

2. Verify that the condition described by the customer exists.
3. Find the malfunction by following the Symptom Chart.
4. Verify malfunction is eliminated.

TROUBLE SYMPTOM CHART

M1429002800238

SYMPTOMS	INSPECTION PROCEDURE	REFERENCE PAGE
Short stroke mechanism does not work. <Driver's side>	1	P.42-28
Short stroke mechanism does not work. <Passenger's side>	2	P.42-38

SYMPTOM PROCEDURES

INSPECTION PROCEDURE 1: Short Stroke Mechanism does not Work. <Driver's Side>

Short Stroke Mechanism Power Supply Circuit <Driver's Side>

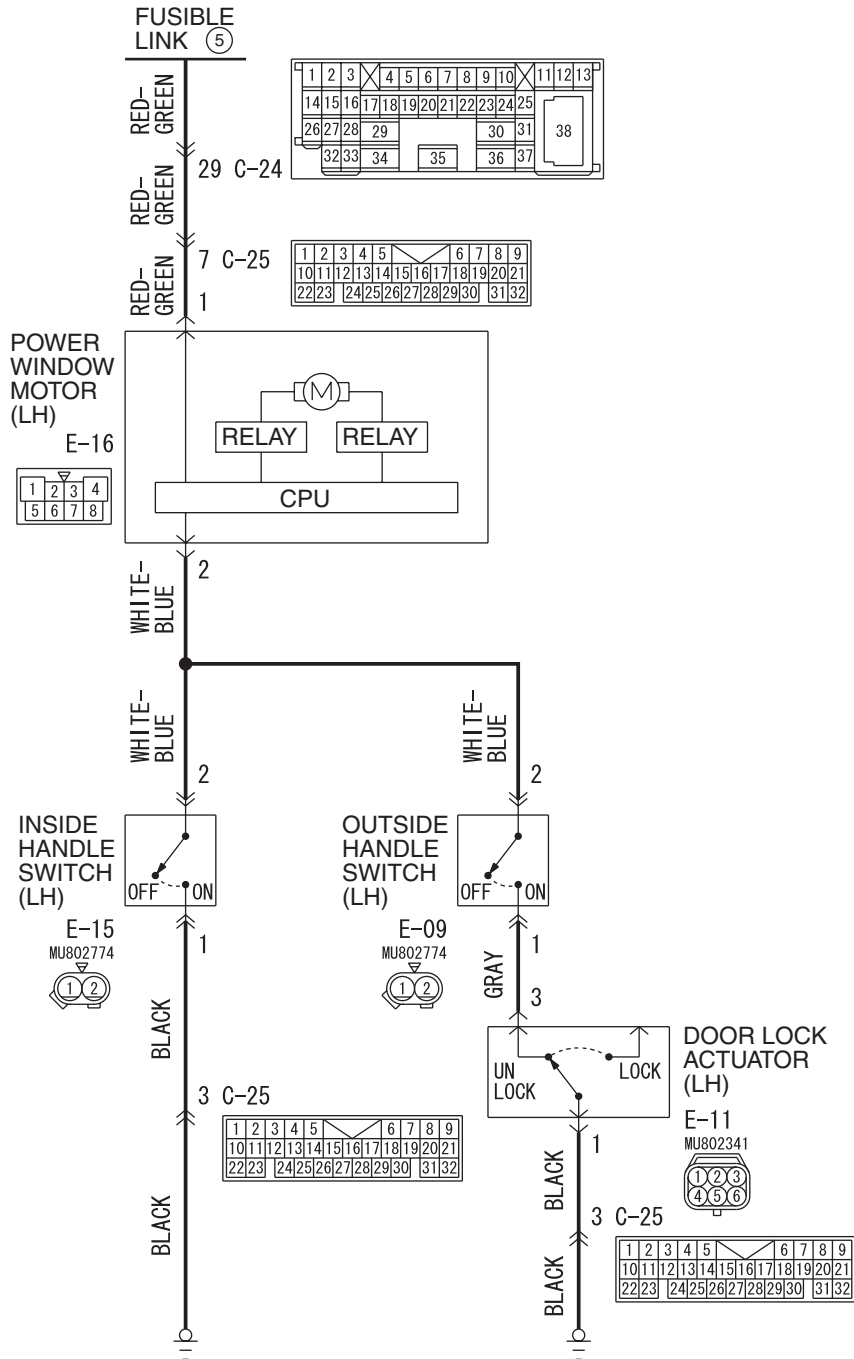

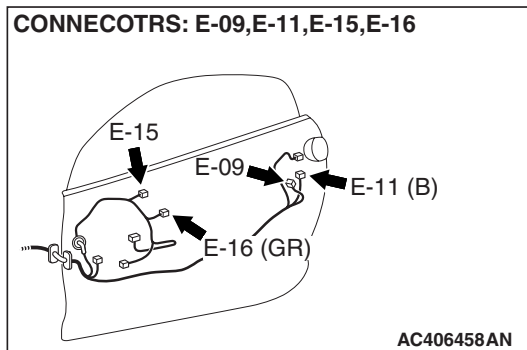
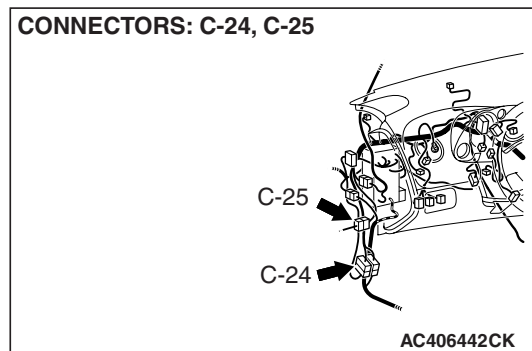
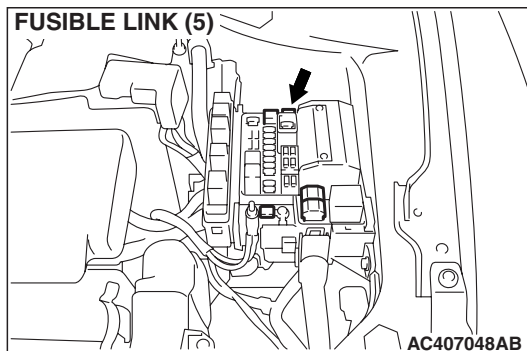

TECHNICAL DESCRIPTION (COMMENT)

The inside handle switch (LH), the outside handle switch (LH) or the power window motor (LH) may be defective.

TROUBLESHOOTING HINTS

- The inside handle switch (LH) may be defective
- The outside handle switch (LH) may be defective
- The power window motor (LH) may be defective
- The wiring harness or connectors may have loose, corroded, or damaged terminals, or terminals pushed back in the connector

DIAGNOSIS

Required Special Tools:

- MB991223: Harness Set
- MB992006: Extra Fine Probe

STEP 1. Short stroke mechanism fully closed position learning procedure.

Carry out the short stroke mechanism fully closed position learning procedure (Refer to [P.42-65](#))

Q: Does the short stroke mechanism (LH) work normally?

YES : The short stroke mechanism (LH) should raise and lower normally.

NO : Go to Step 2.

STEP 2. Verify the power window system.

Q: Does the power window system work normally?

YES : Go to Step 3.

NO : Refer to GROUP 54B, Diagnosis [P.54B-57](#). Check that all the doors can be raised or lowered by operating the power window main switch.

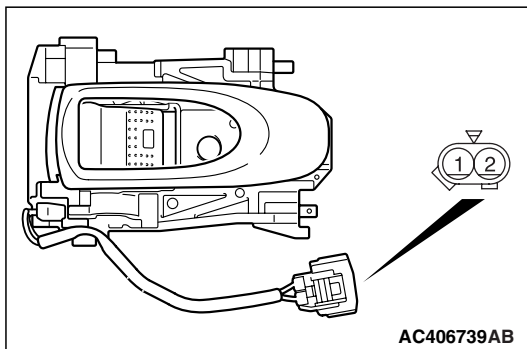
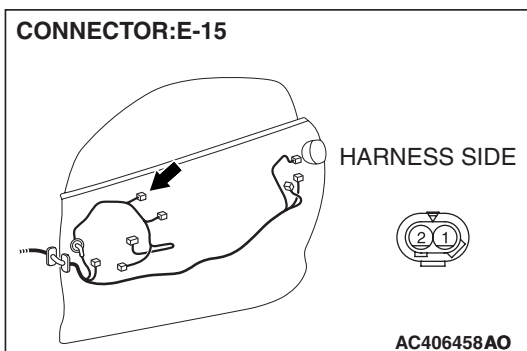
STEP 3. Verify the central door locking system.**Q: Does the central door locking system work normally?****YES :** Go to Step 4.**NO :** Refer to GROUP 54B, Diagnosis [P.54B-57](#). Check that all the doors can be locked or unlocked by operating the driver's side door lock key cylinder and power window switch (door lock switch).**STEP 4. Verify trouble symptom.****Q: Which short stroke mechanism (LH) is defective?****The mechanism does not work only when the inside handle (LH) is operated. :** Go to Step 5.**The mechanism does not work only when the outside handle (LH) is operated. :** Go to Step 10.**The mechanism does not work at all. :** Go to Step 16.**STEP 5. Check inside handle switch (LH) connector E-15 for loose, corroded or damaged terminals, or terminals pushed back in the connector.****Q: Is inside handle switch (LH) connector E-15 in good condition?****YES :** Go to Step 6.**NO :** Repair or replace the damaged component(s). Refer to GROUP 00E, Harness Connector Inspection [P.00E-2](#). When the inside handle switch (LH) is operated, the short stroke mechanism (LH) should raise and lower normally.**STEP 6. Check the inside handle switch (LH) for continuity.**(1) Remove the inside handle (LH). Refer to [P.42-72](#).

(2) Check continuity when the inside handle switch (LH) is operated to "ON" or "OFF" position.

SWITCH POSITION	TESTER CONNECTION	SPECIFIED CONDITION
ON (OPEN)	1 - 2	Less than 2 ohms
OFF (CLOSE)	1 - 2	Open circuit

Q: Is the inside handle switch (LH) normal?**YES :** Go to Step 7.**NO :** Replace the inside handle (LH). When the inside handle switch (LH) is operated, the short stroke mechanism (LH) should raise and lower normally.

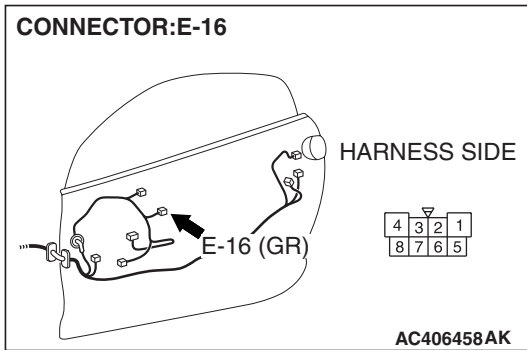

STEP 7. Check power window motor (LH) connector E-16 for loose, corroded or damaged terminals, or terminals pushed back in the connector.

Q: Is power window motor (LH) connector E-16 in good condition?

YES : Go to Step 8.

NO : Repair or replace the damaged component(s). Refer to GROUP 00E, Harness Connector Inspection [P.00E-2](#). When the inside handle switch (LH) is operated, the short stroke mechanism (LH) should raise and lower normally.

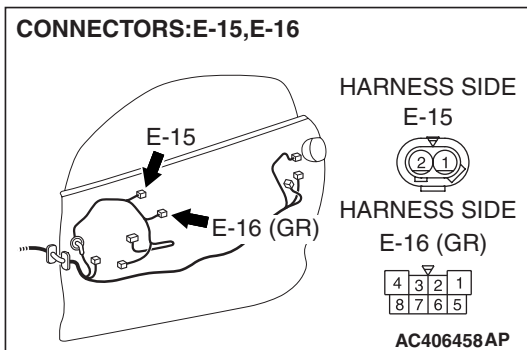

STEP 8. Check the wiring harness between power window motor (LH) connector E-16 (terminal 2) and inside handle switch (LH) connector E-15 (terminal 2).

Q: Is the wiring harness between power window motor (LH) connector E-16 (terminal 2) and inside handle switch (LH) connector E-15 (terminal 2) in good condition?

YES : Go to Step 9.

NO : The wiring harness may be damaged or the connector(s) may have loose, corroded or damaged terminals, or terminals pushed back in the connector. Repair the wiring harness as necessary. When the inside handle switch (LH) is operated, the short stroke mechanism (LH) should raise and lower normally.

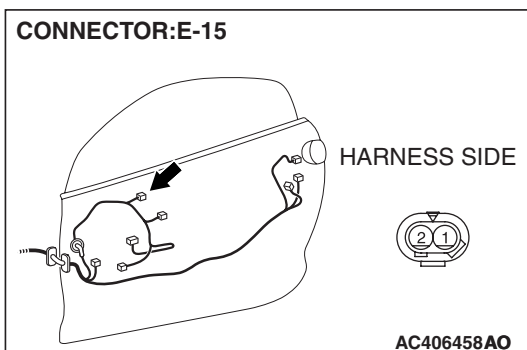

STEP 9. Check the wiring harness between inside handle switch (LH) connector E-15 (terminal 1) and ground.

CONNECTOR: C-25

1	2	3	4	5	6	7	8	9			
10	11	12	13	14	15	16	17	18	19	20	21
22	23	24	25	26	27	28	29	30	31	32	

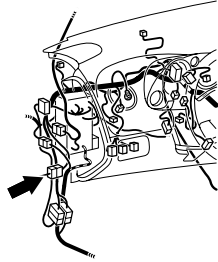

AC406442BR

NOTE: Also check intermediate connector C-25 for loose, corroded or damaged terminals, or terminals pushed back in the connectors. If intermediate connector C-25 is damaged, repair or replace the damaged component(s) as described in GROUP 00E, Harness Connector Inspection P.00E-2.

Q: Is the wiring harness between inside handle switch (LH) connector E-15 (terminal 1) and ground in good condition?

YES : No action is necessary and testing is complete.

NO : The wiring harness may be damaged or the connector(s) may have loose, corroded or damaged terminals, or terminals pushed back in the connector. Repair the wiring harness as necessary. When the inside handle switch (LH) is operated, the short stroke mechanism (LH) should raise and lower normally.

CONNECTOR: E-09

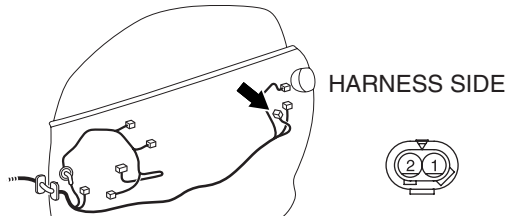

AC406458AQ

STEP 10. Check outside handle switch (LH) connector E-09 for loose, corroded or damaged terminals, or terminals pushed back in the connector.

Q: Is outside handle switch (LH) connector E-09 in good condition?

YES : Go to Step 11.

NO : Repair or replace the damaged component(s). Refer to GROUP 00E, Harness Connector Inspection P.00E-2. When the outside handle switch (LH) is operated, the short stroke mechanism (LH) should raise and lower normally.

STEP 11. Check the outside handle switch (LH) for continuity.

(1) Remove the outside handle (LH). Refer to P.42-72.

(2) Check continuity when the outside handle switch (LH) is operated to "ON" or "OFF" position.

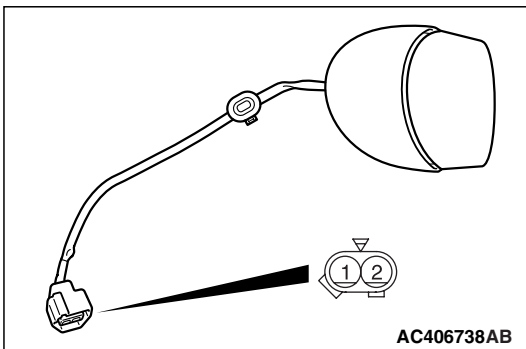

AC406738AB

SWITCH POSITION	TESTER CONNECTION	SPECIFIED CONDITION
ON (OPEN)	1 -2	Less than 2 ohms
OFF (CLOSE)	1 -2	Open circuit

Q: Is the outside handle switch (LH) normal?

YES : Go to Step 12.

NO : Replace the outside handle (LH). When the outside handle switch (LH) is operated, the short stroke mechanism (LH) should raise and lower normally.

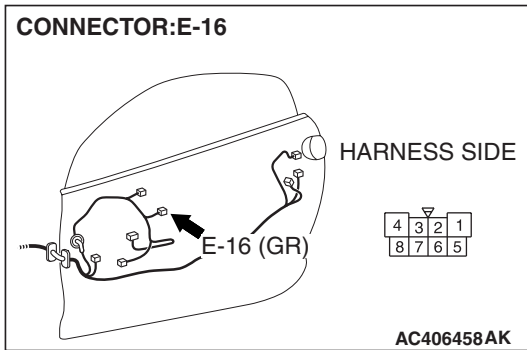

STEP 12. Check power window motor (LH) connector E-16 for loose, corroded or damaged terminals, or terminals pushed back in the connector.

Q: Is power window motor (LH) connector E-16 in good condition?

YES : Go to Step 13.

NO : Repair or replace the damaged component(s). Refer to GROUP 00E, Harness Connector Inspection [P.00E-2](#). When the outside handle switch (LH) is operated, the short stroke mechanism (LH) should raise and lower normally.

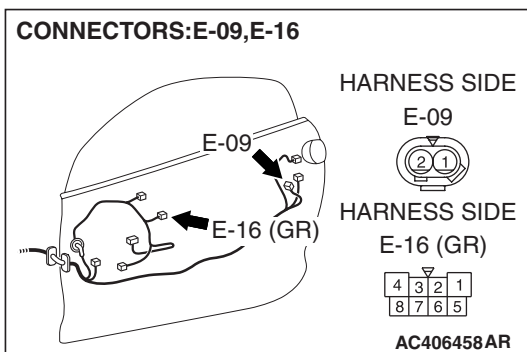

STEP 13. Check the wiring harness between power window motor (LH) connector E-16 (terminal 2) and outside handle switch (LH) connector E-09 (terminal 2).

Q: Is the wiring harness between power window motor (LH) connector E-16 (terminal 2) and outside handle switch (LH) connector E-09 (terminal 2) in good condition?

YES : Go to Step 14.

NO : The wiring harness may be damaged or the connector(s) may have loose, corroded or damaged terminals, or terminals pushed back in the connector. Repair the wiring harness as necessary. When the outside handle switch (LH) is operated, the short stroke mechanism (LH) should raise and lower normally.

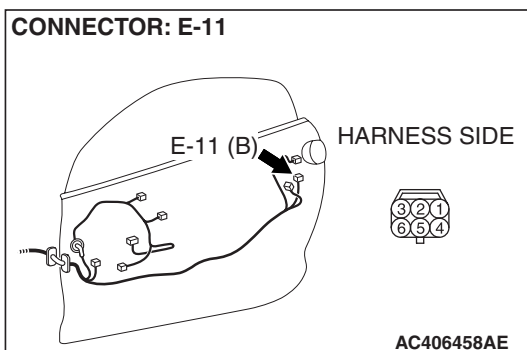

STEP 14. Check door lock actuator (LH) connector E-11 for loose, corroded or damaged terminals, or terminals pushed back in the connector.

Q: Is door lock actuator (LH) connector E-11 in good condition?

YES : Go to Step 15.

NO : Repair or replace the damaged component(s). Refer to GROUP 00E, Harness Connector Inspection [P.00E-2](#). When the outside handle switch (LH) is operated, the short stroke mechanism (LH) should raise and lower normally.

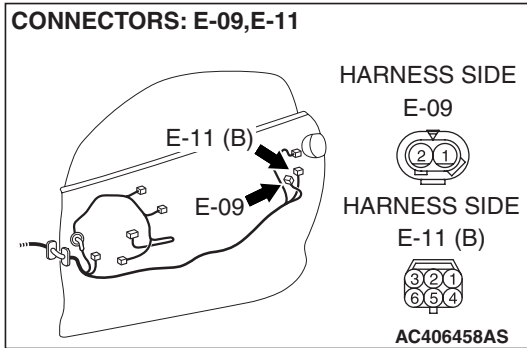

STEP 15. Check the wiring harness between outside handle switch (LH) connector E-09 (terminal 1) and door lock actuator (LH) connector E-11 (terminal 3).

Q: Is the wiring harness between outside handle switch (LH) connector E-09 (terminal 1) and door lock actuator (LH) connector E-11 (terminal 3) in good condition?

YES : No action is necessary and testing is complete.

NO : The wiring harness may be damaged or the connector(s) may have loose, corroded or damaged terminals, or terminals pushed back in the connector. Repair the wiring harness as necessary. When the outside handle switch (LH) is operated, the short stroke mechanism (LH) should raise and lower normally.

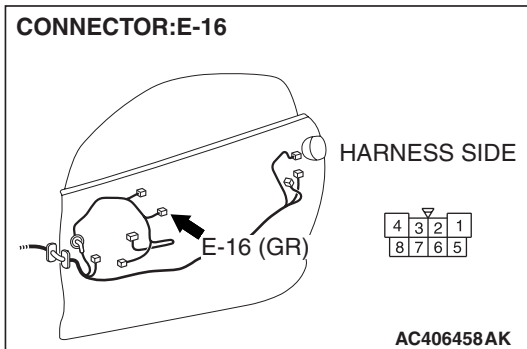

STEP 16. Check power window motor (LH) connector E-16 for loose, corroded or damaged terminals, or terminals pushed back in the connector.

Q: Is power window motor (LH) connector E-16 in good condition?

YES : Go to Step 17.

NO : Repair or replace the damaged component(s). Refer to GROUP 00E, Harness Connector Inspection [P.00E-2](#). The short stroke mechanism (LH) should raise and lower normally.

CONNECTOR:E-16

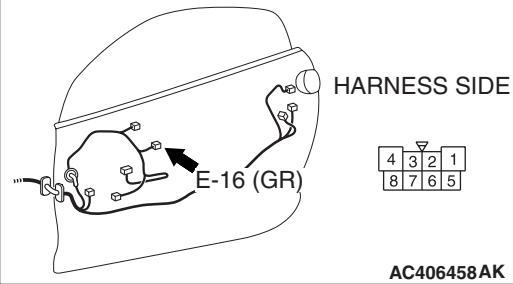

STEP 17. Check the battery power supply circuit to the power window motor (LH). Measure the voltage at power window motor (LH) connector E-16.

(1) Disconnect power window motor (LH) connector E-16 and measure the voltage available at the wiring harness side of the connector.

(2) Turn the ignition switch to "OFF" position.

(3) Measure the voltage between terminal 1 and ground.

- The voltage should measure approximately 12 volts (battery positive voltage).

Q: Is the measured voltage approximately 12 volts (battery positive voltage)?

YES : Go to Step 19.

NO : Go to Step 18.

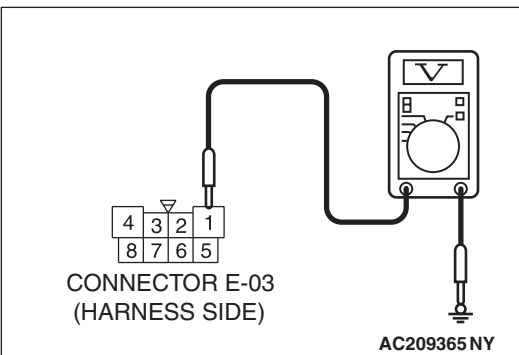

STEP 18. Check the wiring harness between power window motor (LH) connector E-16 (terminal 1) and fusible link (5).

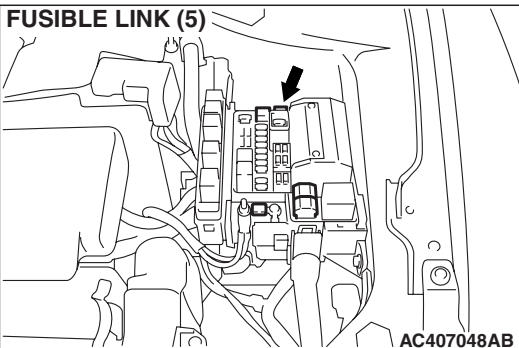

CONNECTOR:E-16

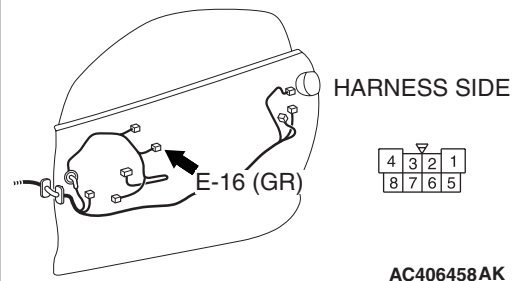

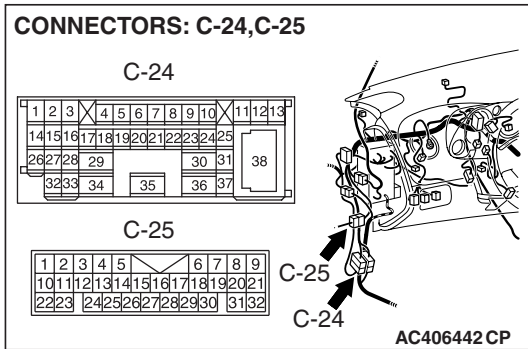

NOTE: Also check intermediate connector C-24 and C-25 for loose, corroded or damaged terminals, or terminals pushed back in the connectors. If intermediate connector C-24 or C-25 is damaged, repair or replace the damaged component(s) as described in GROUP 00E, Harness Connector Inspection P.00E-2.

Q: Is the wiring harness between power window motor (LH) connector E-16 (terminal 1) and fusible link (5) in good condition?

- YES :** No action is necessary and testing is complete.
- NO :** The wiring harness may be damaged or the connector(s) may have loose, corroded or damaged terminals, or terminals pushed back in the connector. Repair the wiring harness as necessary. The short stroke mechanism (LH) should raise and lower normally.

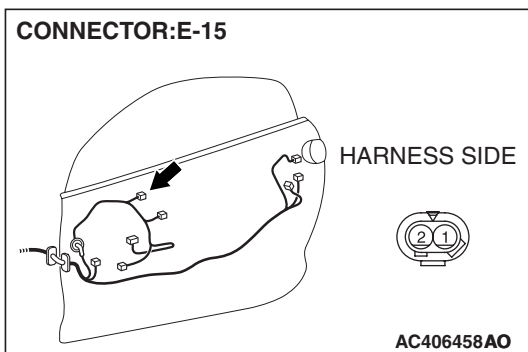

STEP 19. Check inside handle switch (LH) connector E-15 for loose, corroded or damaged terminals, or terminals pushed back in the connector.

Q: Is inside handle switch (LH) connector E-15 in good condition?

- YES :** Go to Step 20.
- NO :** Repair or replace the damaged component(s). Refer to GROUP 00E, Harness Connector Inspection P.00E-2. The short stroke mechanism (LH) should raise and lower normally.

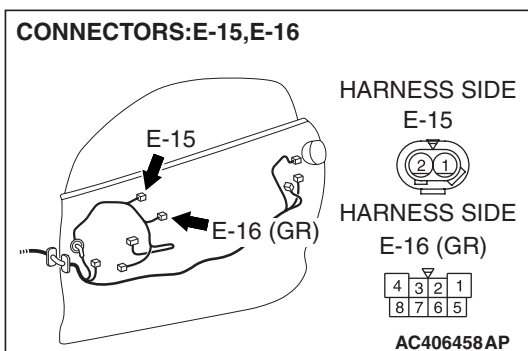

STEP 20. Check the wiring harness between power window motor (LH) connector E-16 (terminal 2) and inside handle switch (LH) connector E-15 (terminal 2).

Q: Is the wiring harness between power window motor (LH) connector E-16 (terminal 2) and inside handle switch (LH) connector E-15 (terminal 2) in good condition?

- YES :** Go to Step 21.
- NO :** The wiring harness may be damaged or the connector(s) may have loose, corroded or damaged terminals, or terminals pushed back in the connector. Repair the wiring harness as necessary. The short stroke mechanism (LH) should raise and lower normally.

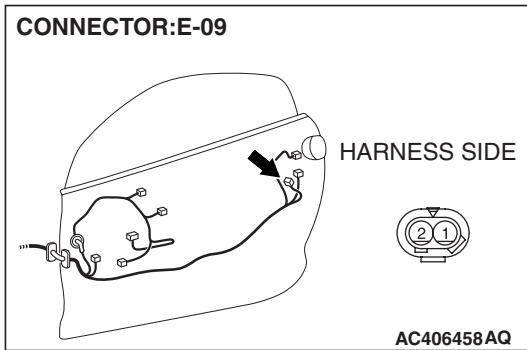

STEP 21. Check outside handle switch (LH) connector E-09 for loose, corroded or damaged terminals, or terminals pushed back in the connector.

Q: Is outside handle switch (LH) connector E-09 in good condition?

YES : Go to Step 22.

NO : Repair or replace the damaged component(s). Refer to GROUP 00E, Harness Connector Inspection [P.00E-2](#). The short stroke mechanism (LH) should raise and lower normally.

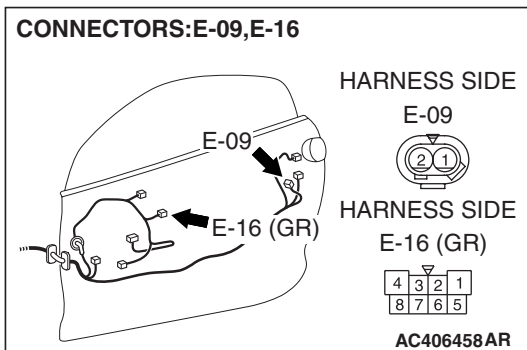

STEP 22. Check the wiring harness between power window motor (LH) connector E-16 (terminal 2) and outside handle switch (LH) connector E-09 (terminal 2).

Q: Is the wiring harness between power window motor (LH) connector E-16 (terminal 2) and outside handle switch (LH) connector E-09 (terminal 2) in good condition?

YES : Replace the door window module assembly (LH). The short stroke mechanism (LH) should raise and lower normally.

NO : The wiring harness may be damaged or the connector(s) may have loose, corroded or damaged terminals, or terminals pushed back in the connector. Repair the wiring harness as necessary. The short stroke mechanism (LH) should raise and lower normally.

INSPECTION PROCEDURE 2: Short Stroke Mechanism does not Work. <Passenger's Side>

Short Stroke Mechanism Power Supply Circuit <Passenger's Side>

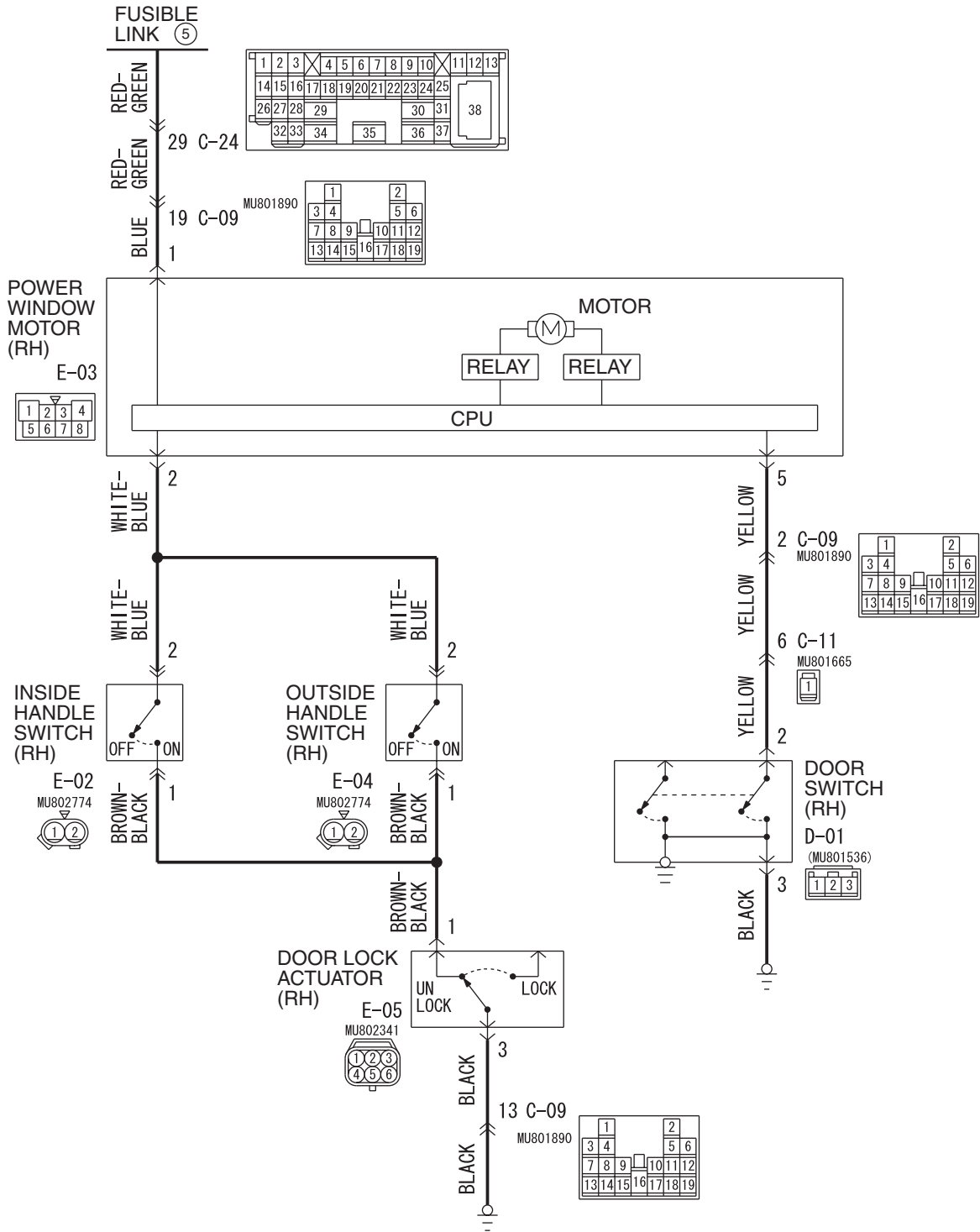

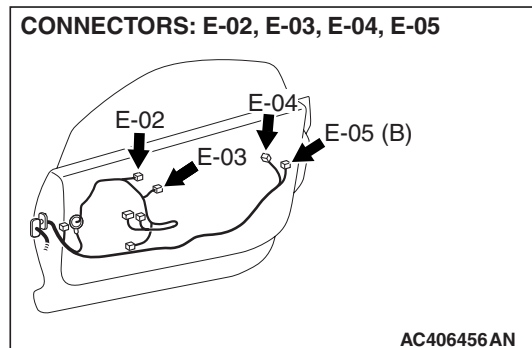
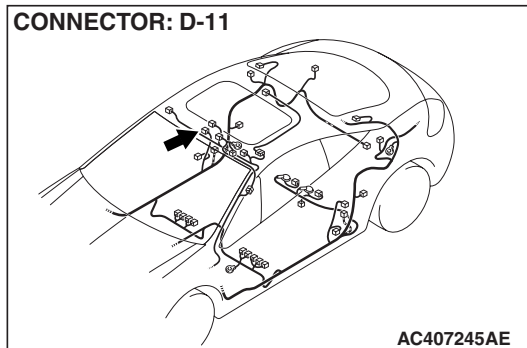
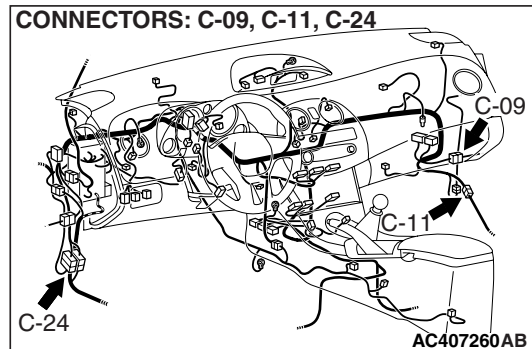
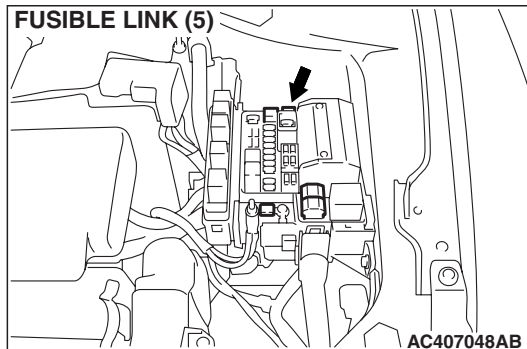

TECHNICAL DESCRIPTION (COMMENT)

The door switch (RH), the inside handle switch (RH), the outside handle switch (RH) or the power window motor (RH) may be defective.

- The inside handle switch (RH) may be defective
- The outside handle switch (RH) may be defective
- The power window motor (RH) may be defective
- The wiring harness or connectors may have loose, corroded, or damaged terminals, or terminals pushed back in the connector

TROUBLESHOOTING HINTS

- The door switch (RH) may be defective

DIAGNOSIS

Required Special Tools:

- MB991223: Harness Set
- MB992006: Extra Fine Probe

STEP 1. Short stroke mechanism fully closed position learning procedure.

Carry out the short stroke mechanism fully closed position learning procedure (Refer to [P.42-65](#))

Q: Does the short stroke mechanism (RH) work normally?

- YES :** The short stroke mechanism (RH) should raise and lower normally.
- NO :** Go to Step 2.

STEP 2. Verify the power window system.

Q: Does the power window system work normally?

- YES :** Go to Step 3.
- NO :** Refer to GROUP 54B, Diagnosis [P.54B-57](#). Check that all the doors can be raised or lowered by operating the power window main switch and power window sub switch.

STEP 3. Verify the central door locking system.

Q: Does the central door locking system work normally?

YES : Go to Step 4.

NO : Refer to GROUP 54B, Diagnosis [P.54B-57](#). Check that all the doors can be locked or unlocked by operating the driver's side door lock key cylinder and power window switch (door lock switch).

STEP 4. Verify trouble symptom.

Q: Which short stroke mechanism (RH) is defective?

The mechanism does not work only when the inside handle (RH) is operated. : Go to Step 5.

The mechanism does not work only when the outside handle (RH) is operated. : Go to Step 11.

The mechanism does not work only when the door (RH) is closed. : Go to Step 17.

The mechanism does not work at all. : Go to Step 22.

STEP 5. Check inside handle switch (RH) connector E-02 for loose, corroded or damaged terminals, or terminals pushed back in the connector.

Q: Is inside handle switch (RH) connector E-02 in good condition?

YES : Go to Step 6.

NO : Repair or replace the damaged component(s). Refer to GROUP 00E, Harness Connector Inspection [P.00E-2](#). When the inside handle switch (RH) is operated, the short stroke mechanism (RH) should raise and lower normally.

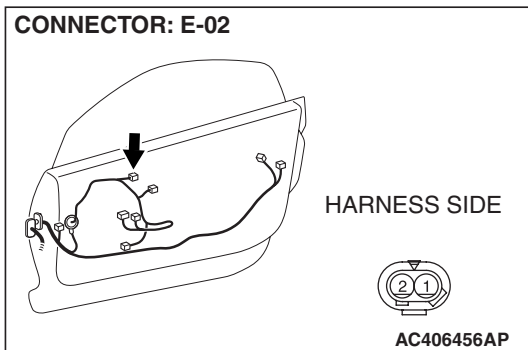

STEP 6. Check the inside handle switch (RH) for continuity.

(1) Remove the inside handle (RH). Refer to [P.42-72](#).

(2) Check continuity when the inside handle switch (RH) is operated to "ON" or "OFF" position.

SWITCH POSITION	TESTER CONNECTION	SPECIFIED CONDITION
ON (OPEN)	1 – 2	Less than 2 ohms
OFF (CLOSE)	1 – 2	Open circuit

Q: Is the inside handle switch (RH) normal?

YES : Go to Step 7.

NO : Replace the inside handle (RH). When the inside handle switch (RH) is operated, the short stroke mechanism (RH) should raise and lower normally.

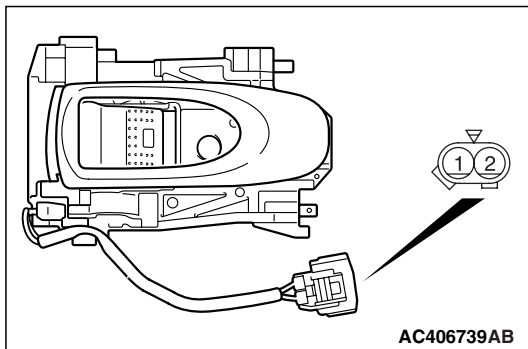

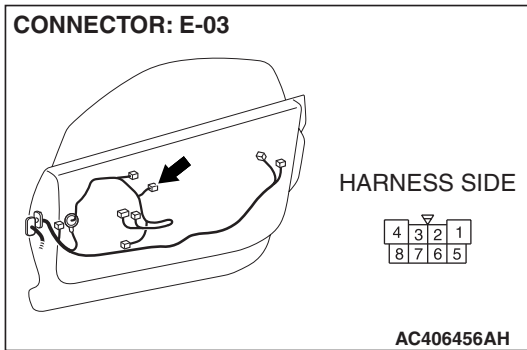

STEP 7. Check power window motor (RH) connector E-03 for loose, corroded or damaged terminals, or terminals pushed back in the connector.

Q: Is power window motor (RH) connector E-03 in good condition?

YES : Go to Step 8.

NO : Repair or replace the damaged component(s). Refer to GROUP 00E, Harness Connector Inspection [P.00E-2](#). When the inside handle switch (RH) is operated, the short stroke mechanism (RH) should raise and lower normally.

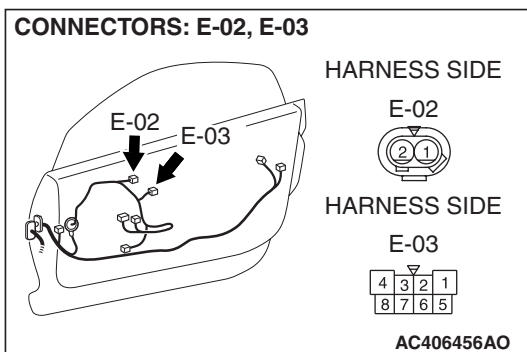

STEP 8. Check the wiring harness between power window motor (RH) connector E-03 (terminal 2) and inside handle switch (RH) connector E-02 (terminal 2).

Q: Is the wiring harness between power window motor (RH) connector E-03 (terminal 2) and inside handle switch (RH) connector E-02 (terminal 2) in good condition?

YES : Go to Step 9.

NO : The wiring harness may be damaged or the connector(s) may have loose, corroded or damaged terminals, or terminals pushed back in the connector. Repair the wiring harness as necessary. When the inside handle switch (RH) is operated, the short stroke mechanism (RH) should raise and lower normally.

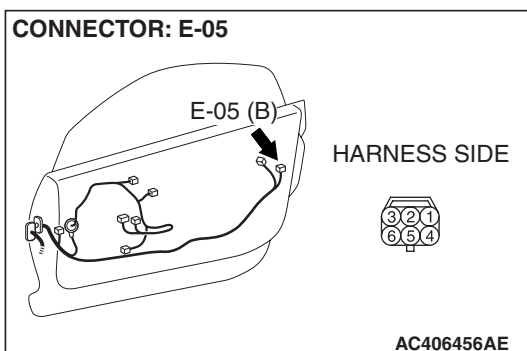

STEP 9. Check door lock actuator (RH) connector E-05 for loose, corroded or damaged terminals, or terminals pushed back in the connector.

Q: Is door lock actuator (RH) connector E-05 in good condition?

YES : Go to Step 10.

NO : Repair or replace the damaged component(s). Refer to GROUP 00E, Harness Connector Inspection [P.00E-2](#). When the inside handle switch (RH) is operated, the short stroke mechanism (RH) should raise and lower normally.

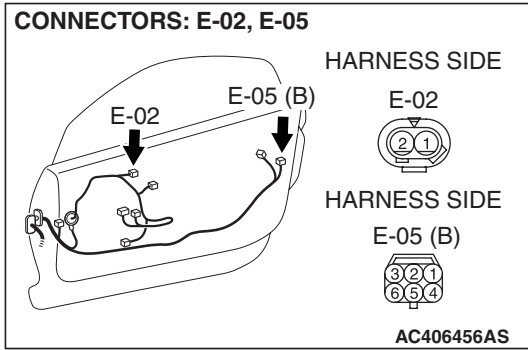

STEP 10. Check the wiring harness between inside handle switch (RH) connector E-02 (terminal 1) and door lock actuator (RH) connector E-05 (terminal 1).

Q: Is the wiring harness between inside handle switch (RH) connector E-02 (terminal 1) and door lock actuator (RH) connector E-05 (terminal 1) in good condition?

YES : No action is necessary and testing is complete.

NO : The wiring harness may be damaged or the connector(s) may have loose, corroded or damaged terminals, or terminals pushed back in the connector. Repair the wiring harness as necessary. When the inside handle switch (RH) is operated, the short stroke mechanism (RH) should raise and lower normally.

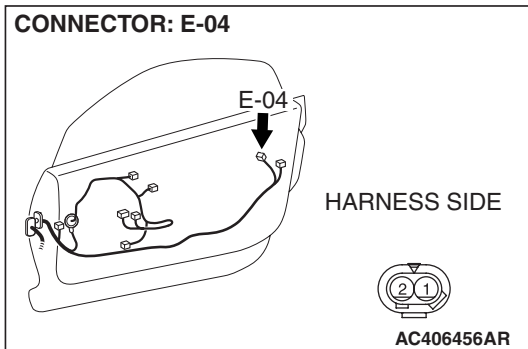

STEP 11. Check outside handle switch (RH) connector E-04 for loose, corroded or damaged terminals, or terminals pushed back in the connector.

Q: Is outside handle switch (RH) connector E-04 in good condition?

YES : Go to Step 12.

NO : Repair or replace the damaged component(s). Refer to GROUP 00E, Harness Connector Inspection [P.00E-2](#). When the outside handle switch (RH) is operated, the short stroke mechanism (RH) should raise and lower normally.

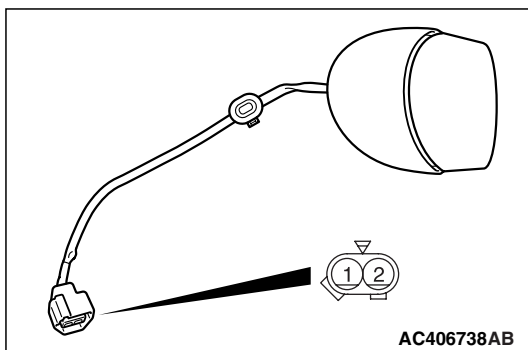

STEP 12. Check the outside handle switch (RH) for continuity.

(1) Remove the outside handle (RH). Refer to [P.42-72](#).

(2) Check continuity when the outside handle switch (RH) is operated to "ON" or "OFF" position.

SWITCH POSITION	TESTER CONNECTION	SPECIFIED CONDITION
ON (OPEN)	1 – 2	Less than 2 ohms
OFF (CLOSE)	1 – 2	Open circuit

Q: Is the outside handle switch (RH) normal?

YES : Go to Step 13.

NO : Replace the outside handle (RH). When the outside handle switch (RH) is operated, the short stroke mechanism (RH) should raise and lower normally.

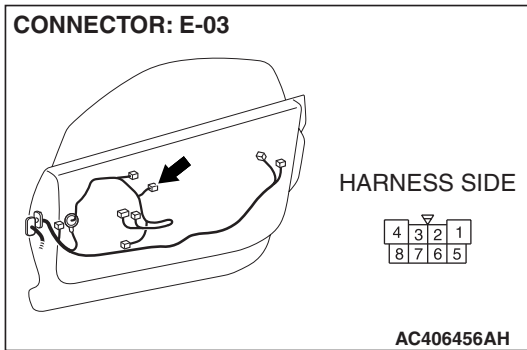

STEP 13. Check power window motor (RH) connector E-03 for loose, corroded or damaged terminals, or terminals pushed back in the connector.

Q: Is power window motor (RH) connector E-03 in good condition?

YES : Go to Step 14.

NO : Repair or replace the damaged component(s). Refer to GROUP 00E, Harness Connector Inspection [P.00E-2](#). When the outside handle switch (RH) is operated, the short stroke mechanism (RH) should raise and lower normally.

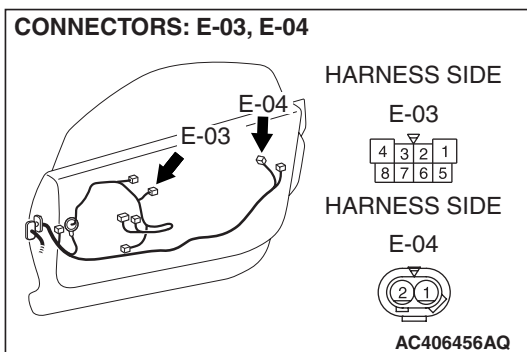

STEP 14. Check the wiring harness between power window motor (RH) connector E-03 (terminal 2) and outside handle switch (RH) connector E-04 (terminal 2).

Q: Is the wiring harness between power window motor (RH) connector E-03 (terminal 2) and outside handle switch (RH) connector E-04 (terminal 2) in good condition?

YES : Go to Step 15.

NO : The wiring harness may be damaged or the connector(s) may have loose, corroded or damaged terminals, or terminals pushed back in the connector. Repair the wiring harness as necessary. When the outside handle switch (RH) is operated, the short stroke mechanism (RH) should raise and lower normally.

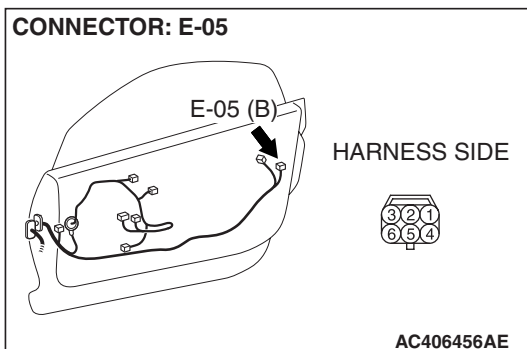

STEP 15. Check door lock actuator (RH) connector E-05 for loose, corroded or damaged terminals, or terminals pushed back in the connector.

Q: Is door lock actuator (RH) connector E-05 in good condition?

YES : Go to Step 16.

NO : Repair or replace the damaged component(s). Refer to GROUP 00E, Harness Connector Inspection [P.00E-2](#). When the outside handle switch (RH) is operated, the short stroke mechanism (RH) should raise and lower normally.

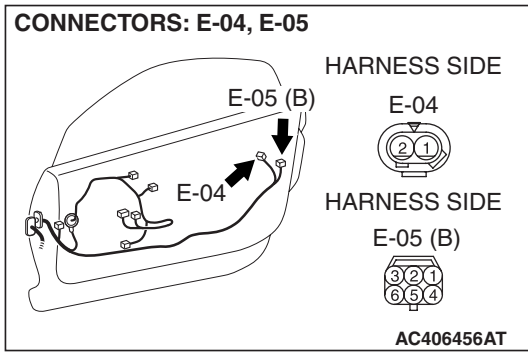

STEP 16. Check the wiring harness between outside handle switch (RH) connector E-04 (terminal 1) and door lock actuator (RH) connector E-05 (terminal 1).

Q: Is the wiring harness between outside handle switch (RH) connector E-04 (terminal 1) and door lock actuator (RH) connector E-05 (terminal 1) in good condition?

YES : No action is necessary and testing is complete.

NO : The wiring harness may be damaged or the connector(s) may have loose, corroded or damaged terminals, or terminals pushed back in the connector. Repair the wiring harness as necessary. When the outside handle switch (RH) is operated, the short stroke mechanism (RH) should raise and lower normally.

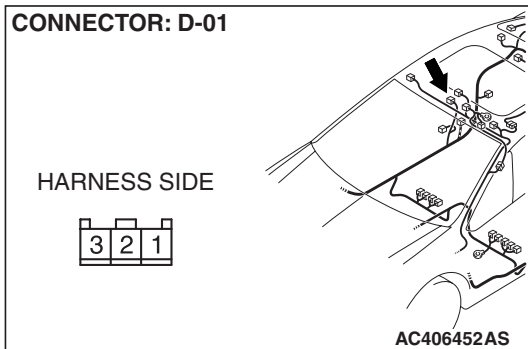

STEP 17. Check door switch (RH) connector D-01 for loose, corroded or damaged terminals, or terminals pushed back in the connector.

Q: Is door switch (RH) connector D-01 in good condition?

YES : Go to Step 18.

NO : Repair or replace the damaged component(s). Refer to GROUP 00E, Harness Connector Inspection [P.00E-2](#). When the door switch (RH) is operated, the short stroke mechanism (RH) should raise and lower normally.

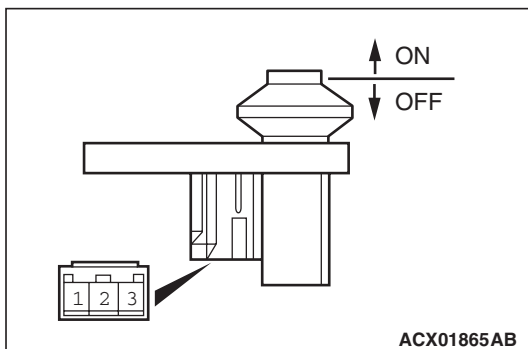

STEP 18. Check the door switch (RH) for continuity.

- (1) Remove the door switch (RH). Refer to [P.42-68](#).
- (2) Check continuity when the door switch (RH) is operated to "ON" or "OFF" position.

SWITCH POSITION	TESTER CONNECTION	SPECIFIED CONDITION
Released (ON)	2 –body ground	Less than 2 ohms
Depressed (OFF)	2 –body ground	Open circuit

Q: Is the door switch (RH) normal?

YES : Go to Step 19.

NO : Replace the door switch (RH). When the door (RH) is operated, the short stroke mechanism (RH) should raise and lower normally.

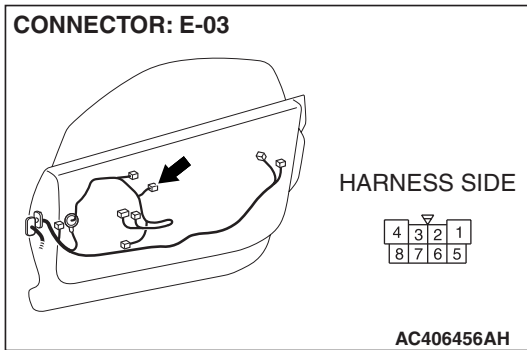

STEP 19. Check power window motor (RH) connector E-03 for loose, corroded or damaged terminals, or terminals pushed back in the connector.

Q: Is power window motor (RH) connector E-03 in good condition?

YES : Go to Step 20.

NO : Repair or replace the damaged component(s). Refer to GROUP 00E, Harness Connector Inspection [P.00E-2](#). When the door switch (RH) is operated, the short stroke mechanism (RH) should raise and lower normally.

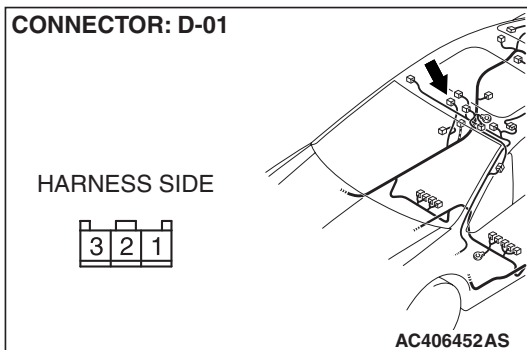

STEP 20. Check the wiring harness between power window motor (RH) connector E-03 (terminal 5) and door switch (RH) connector D-01 (terminal 2).

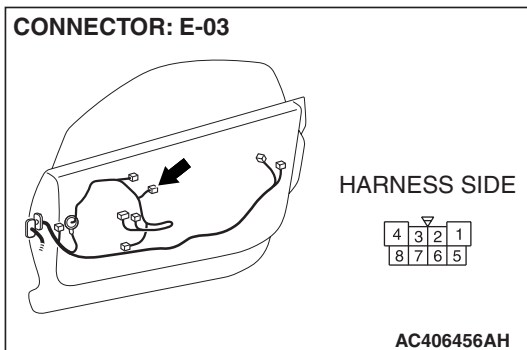

CONNECTORS: C-09, C-11

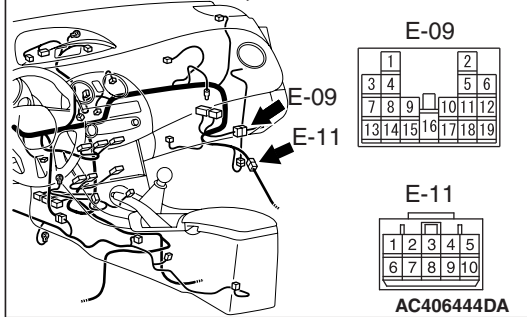

NOTE: Also check intermediate connector C-09 and C-11 for loose, corroded or damaged terminals, or terminals pushed back in the connectors. If intermediate connector C-09 or C-11 is damaged, repair or replace the damaged component(s) as described in GROUP 00E, Harness Connector Inspection P.00E-2.

Q: Is the wiring harness between power window motor (RH) connector E-03 (terminal 2) and door switch (RH) connector D-01 (terminal 2) in good condition?

YES : Go to Step 21.

NO : The wiring harness may be damaged or the connector(s) may have loose, corroded or damaged terminals, or terminals pushed back in the connector. Repair the wiring harness as necessary. When the door switch (RH) is operated, the short stroke mechanism (RH) should raise and lower normally.

CONNECTOR: D-01

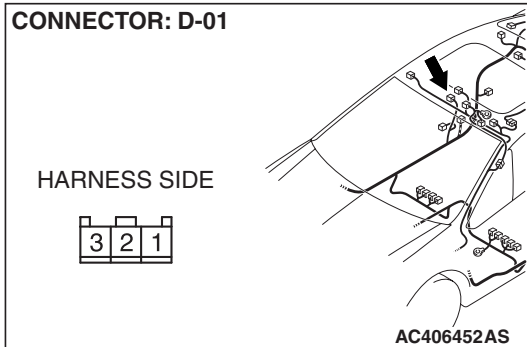

STEP 21. Check the wiring harness between door switch (RH) connector D-01 (terminal 3) and ground.

Q: Is the wiring harness between door switch (RH) connector D-01 (terminal 3) and ground in good condition?

YES : No action is necessary and testing is complete.

NO : The wiring harness may be damaged or the connector(s) may have loose, corroded or damaged terminals, or terminals pushed back in the connector. Repair the wiring harness as necessary. When the door switch (RH) is operated, the short stroke mechanism (RH) should raise and lower normally.

CONNECTOR: E-03

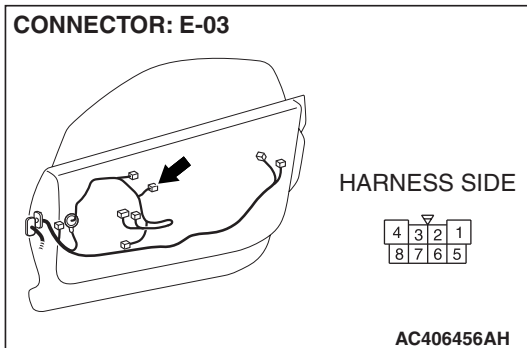

STEP 22. Check power window motor (RH) connector E-03 for loose, corroded or damaged terminals, or terminals pushed back in the connector.

Q: Is power window motor (RH) connector E-03 in good condition?

YES : Go to Step 23.

NO : Repair or replace the damaged component(s). Refer to GROUP 00E, Harness Connector Inspection P.00E-2. The short stroke mechanism (RH) should raise and lower normally.

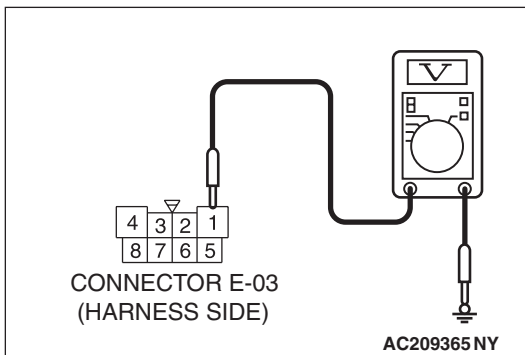
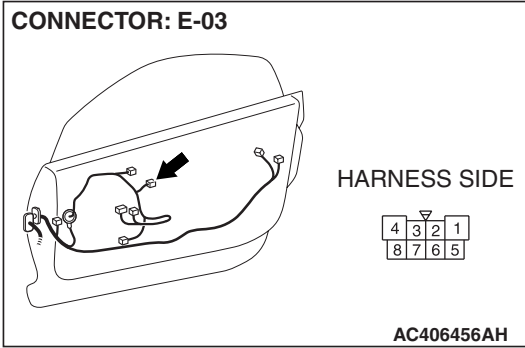

STEP 23. Check the battery power supply circuit to the power window motor (RH). Measure the voltage at power window motor (RH) connector E-03.

(1) Disconnect power window motor (RH) connector E-03 and measure the voltage available at the wiring harness side of the connector.

(2) Turn the ignition switch to "OFF" position.

(3) Measure the voltage between terminal 1 and ground.

- The voltage should measure approximately 12 volts (battery positive voltage).

Q: Is the measured voltage approximately 12 volts (battery positive voltage)?

YES : Go to Step 25.

NO : Go to Step 24.

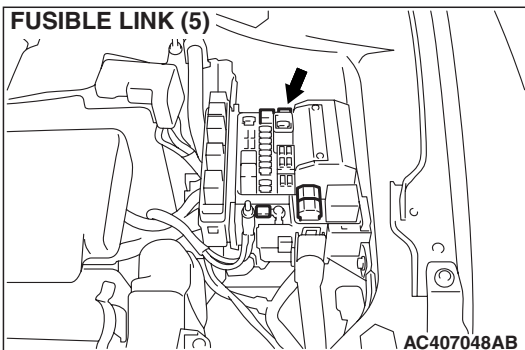

STEP 24. Check the wiring harness between power window motor (RH) connector E-03 (terminal 1) and fusible link (5).

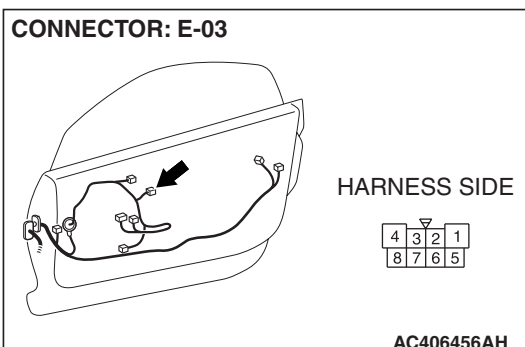

CONNECTOR: C-09

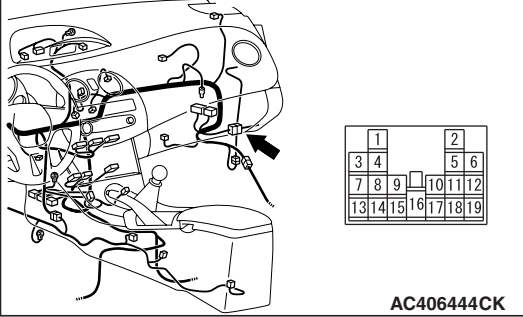

NOTE: Also check intermediate connector C-09 and C-24 for loose, corroded or damaged terminals, or terminals pushed back in the connectors. If intermediate connector C-09 or C-24 is damaged, repair or replace the damaged component(s) as described in GROUP 00E, Harness Connector Inspection P.00E-2.

CONNECTOR: C-24

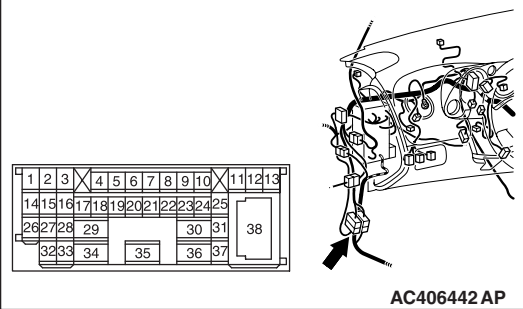

Q: Is the wiring harness between power window motor (RH) connector E-03 (terminal 1) and fusible link (5) in good condition?

- YES :** No action is necessary and testing is complete.
- NO :** The wiring harness may be damaged or the connector(s) may have loose, corroded or damaged terminals, or terminals pushed back in the connector. Repair the wiring harness as necessary. The short stroke mechanism (RH) should raise and lower normally.

CONNECTOR: E-02

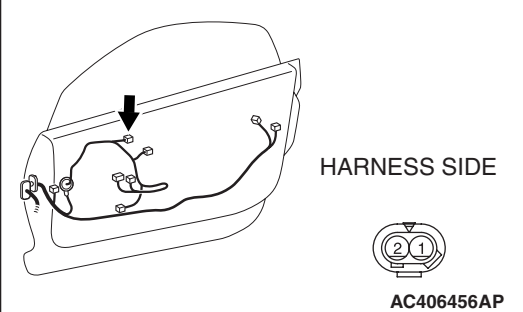

STEP 25. Check inside handle switch (RH) connector E-02 for loose, corroded or damaged terminals, or terminals pushed back in the connector.

Q: Is inside handle switch (RH) connector E-02 in good condition?

- YES :** Go to Step 26.
- NO :** Repair or replace the damaged component(s). Refer to GROUP 00E, Harness Connector Inspection P.00E-2. The short stroke mechanism (RH) should raise and lower normally.

CONNECTORS: E-02, E-03

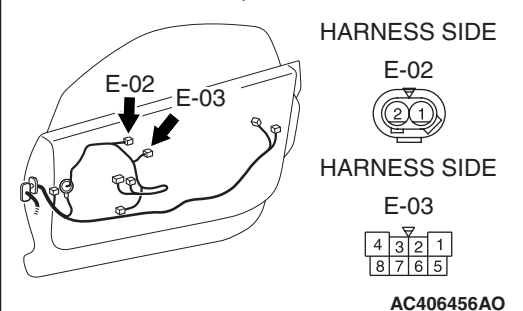

STEP 26. Check the wiring harness between power window motor (RH) connector E-03 (terminal 2) and inside handle switch (RH) connector E-02 (terminal 2).

Q: Is the wiring harness between power window motor (RH) connector E-03 (terminal 2) and inside handle switch (RH) connector E-02 (terminal 2) in good condition?

- YES :** Go to Step 27.
- NO :** The wiring harness may be damaged or the connector(s) may have loose, corroded or damaged terminals, or terminals pushed back in the connector. Repair the wiring harness as necessary. The short stroke mechanism (RH) should raise and lower normally.

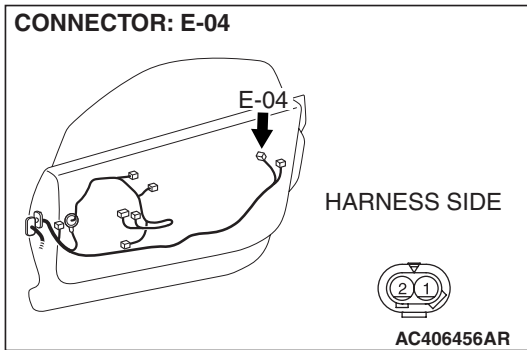

STEP 27. Check outside handle switch (RH) connector E-04 for loose, corroded or damaged terminals, or terminals pushed back in the connector.

Q: Is outside handle switch (RH) connector E-04 in good condition?

YES : Go to Step 28.

NO : Repair or replace the damaged component(s). Refer to GROUP 00E, Harness Connector Inspection P.00E-2. The short stroke mechanism (RH) should raise and lower normally.

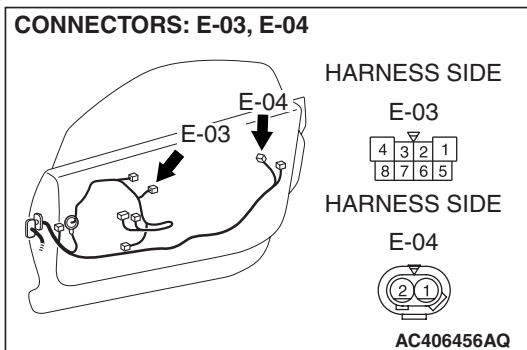

STEP 28. Check the wiring harness between power window motor (RH) connector E-03 (terminal 2) and outside handle switch (RH) connector E-04 (terminal 2).

Q: Is the wiring harness between power window motor (RH) connector E-03 (terminal 2) and outside handle switch (RH) connector E-04 (terminal 2) in good condition?

YES : Replace the door window module assembly (RH). The short stroke mechanism (RH) should raise and lower normally.

NO : The wiring harness may be damaged or the connector(s) may have loose, corroded or damaged terminals, or terminals pushed back in the connector. Repair the wiring harness as necessary. The short stroke mechanism (RH) should raise and lower normally.

DOOR DIAGNOSIS

INTRODUCTION TO GLASS AND DOOR DIAGNOSIS

Glass and door faults include water leaks and improper opening and closing. Causes for these faults can include faults in the glass, weatherstrip, drain hole or door installation.

M1423007300274

GLASS AND DOOR DIAGNOSTIC TROUBLESHOOTING STRATEGY

M1423006700291

Use these steps to plan your diagnostic strategy. If you follow them carefully, you will be sure that you have exhausted most of the possible ways to find a glass and door fault.

1. Gather information from the customer.

2. Verify that the condition described by the customer exists.
3. Find the malfunction by following the Symptom Chart.
4. Verify malfunction is eliminated.

SYMPTOM CHART

SYMPTOM	INSPECTION PROCEDURE	REFERENCE PAGE
Water leak through door window glass	1	P.42-50
Door window glass malfunction	2	P.42-50
Water leak through door edge	3	P.42-51
Water leak from door center	4	P.42-51
Door hard to open	5	P.42-51
Door does not open or close completely	6	P.42-52
Uneven gap between body	7	P.42-52
Wind noise around door	8	P.42-52

SYMPTOM PROCEDURES**INSPECTION PROCEDURE 1: Water Leak Through Door Window Glass****DIAGNOSIS****STEP 1. Check the window glass runchannel.**

Q: Is the window glass runchannel in good condition?

YES : Go to Step 2.

NO : Replace the runchannel, then go to Step 4.

STEP 2. Check the door window glass installation.

Q: Is the door window glass installed correctly?

YES : Go to Step 3.

NO : Reinstall the door window glass (Refer to P.42-70). Then go to Step 4.

STEP 3. Check the clearance at the top of the door window glass.

Q: Is the clearance at the top of the door window glass correct?

YES : Go to Step 4.

NO : Adjust the door window glass (Refer to P.42-56). Then go to Step 4.

STEP 4. Retest the system.

Q: Is any water leaking?

YES : Return to Step 1.

NO : The procedure is complete.

INSPECTION PROCEDURE 2: Door Window Glass Malfunction**DIAGNOSIS****STEP 1. Check the door window glass installation condition.**

Q: Is the door window installed correctly?

YES : Go to Step 2.

NO : Reinstall the door window glass (Refer to P.42-70). Then go to Step 4.

STEP 2. Check the delta window glass.

Q: Is the delta window glass in good condition?

YES : Go to Step 3.

NO : Repair or replace delta window glass, then go to Step 4.

STEP 3. Inspect the window regulator assembly.

Q: Is the window regulator assembly in good condition?
YES : Go to Step 4.
NO : Repair or replace the window regulator assembly, then go to Step 4.

STEP 4. Retest the system.

Q: Does the door window operate correctly?
YES : The procedure is complete.
NO : Return to Step 1.

INSPECTION PROCEDURE 3: Water Leak Through Door Edge

DIAGNOSIS

STEP 1. Check the weatherstrip.

Q: Is the weatherstrip in good condition?
YES : Go to Step 2.
NO : Replace the weatherstrip, then go to Step 3.

STEP 2. Check the door fit (alignment).

Q: Is the door fit (alignment) correct?
YES : Go to Step 3.
NO : Adjust the door fit (Refer to [P.42-56](#)). Then go to Step 3.

STEP 3. Retest the system.

Q: Is any water leaking?
YES : Return to Step 1.
NO : The procedure is complete.

INSPECTION PROCEDURE 4: Water Leak from Door Center

DIAGNOSIS

STEP 1. Check the drain hole.

Q: Is the drain hole clogged?
YES : Clean the drain hole, then go to Step 3.
NO : Go to Step 2.

STEP 2. Check the weatherstrip.

Q: Is the weatherstrip in good condition?
YES : Go to Step 3.
NO : Repair or replace the weatherstrip, then go to Step 3.

STEP 3. Retest the system.

Q: Is any water leaking?
YES : Return to Step 1.
NO : The procedure is complete.

INSPECTION PROCEDURE 5: Door Hard to Open

DIAGNOSIS

STEP 1. Adjust the latch and striker engagement.

Q: Is the latch and striker engagement adjusted?
YES : Go to Step 2.
NO : Adjust the latch and striker (Refer to [P.42-56](#)). Then go to Step 4.

STEP 2. Check for lock cable and lock rod damage.

Q: Are the lock cable and the lock rod damaged?
YES : Repair or replace the lock cable and the lock rod, then go to Step 4.
NO : Go to Step 3.

STEP 3. Check the door handle flexibility
(amount of movement of handle required to open door).

Q: Is the door handle flexibility good?

YES : Go to Step 4.

NO : Check the door outside handle and inside handle (Refer to [P.42-66](#) and [P.42-66](#)).
Then go to Step 4.

STEP 4. Retest the system.

Q: Does the door open easily?

YES : The procedure is complete.

NO : Return to Step 1.

INSPECTION PROCEDURE 6: Door does not Open or Close Completely

DIAGNOSIS

STEP 1. Check the door hinge position.

Q: Is the door hinge correct?

YES : Go to Step 2.

NO : Adjust the door hinge (Refer to [P.42-56](#)).
Then go to Step 4.

STEP 2. Check the door for damage.

Q: Is the door in good condition?

YES : Go to Step 3.

NO : Repair or replace the door, then go to Step 4.

STEP 3. Check lubrication.

Q: Are the door check and door hinge sufficiently lubricated?

YES : Go to Step 4.

NO : Apply grease, then go to Step 4.

STEP 4. Retest the system.

Q: Does the door open and close completely?

YES : The procedure is complete.

NO : Return to Step 1.

INSPECTION PROCEDURE 7: Uneven Gap Between Body

DIAGNOSIS

Adjust the door fit (Refer to [P.42-56](#)). Then check that the gap has been improved.

INSPECTION PROCEDURE 8: Wind Noise Around Door

DIAGNOSIS

STEP 1. Check the weatherstrip for holding condition.

Q: Is the weatherstrip holding firmly?

YES : Go to Step 2.

NO : Adjust fit of weatherstrip. Then go to Step 5.

STEP 2. Check the weatherstrip for installation condition.

Q: Is the weatherstrip installed properly?

YES : Go to Step 3.

NO : Repair or replace the weatherstrip. Then go to Step 5.

STEP 3. Check the clearance.

- Q: Are the door glass and door weatherstrip holder installed properly?**
YES : Go to Step 4.
NO : Adjust the door glass and the weatherstrip holder (Refer to [P.42-58](#)). Then go to Step 5.

STEP 4. Check the door for deformation.

- Q: Is the door deformed?**
YES : Replace the door. Then go to Step 5.
NO : Go to Step 5.

STEP 5. Retest the system.

- Q: Has the wind noise been improved?**
YES : Return to Step 1.
NO : This diagnosis complete.

HOW TO LOCATE WIND NOISE

M1421004200250

1. Attach cloth tape to every place, such as panel seams, projections, molding seams, glass and body seams, etc. which might conceivably be the source of wind noise.
2. Then make a road test to check that the places not covered by tape are not sources of wind noise.

3. Remove the strips of tape one by one, making a road test after each is removed, until a wind noise source is discovered.

4. When such a place is found, cover it again and repeat the procedure to check if there are any other noise source.
5. If no others are found, the last remaining tape is the only source.

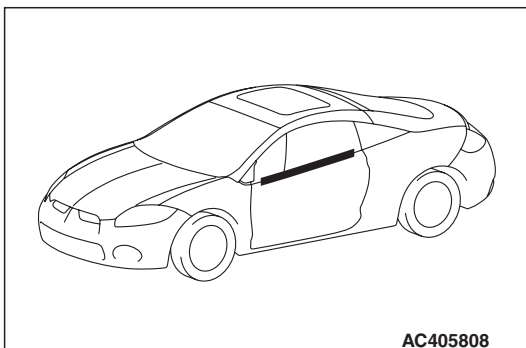
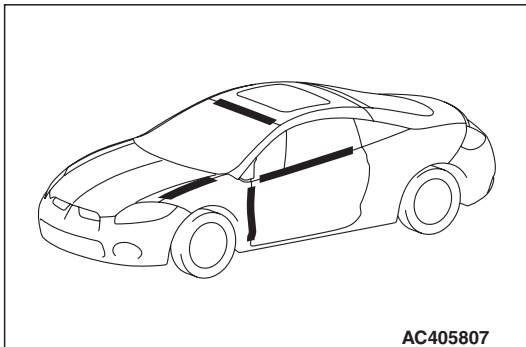
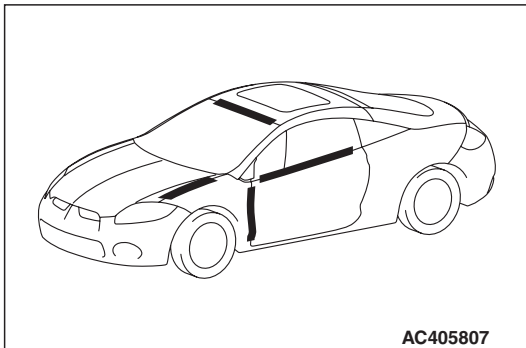

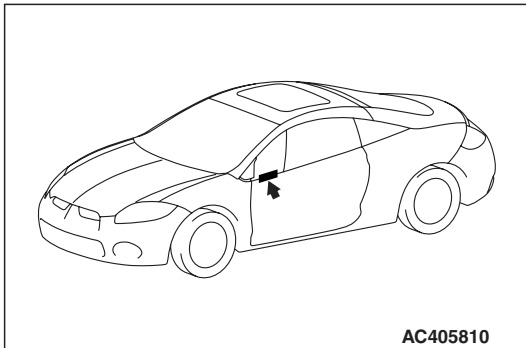
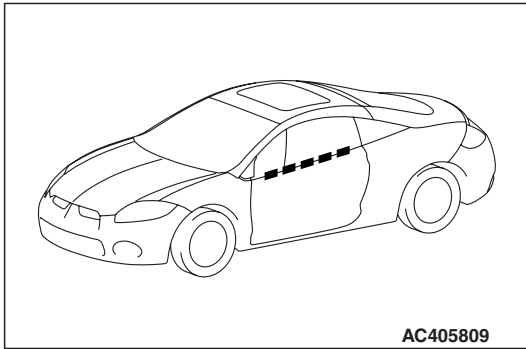







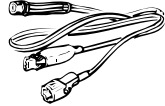
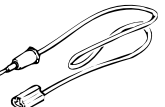
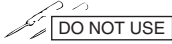

6. Cut the remaining piece of tape into smaller pieces, attach it again as it was before, and then remove the pieces one by one to narrow down the source.
7. Check that wind noise occurs when the last remaining tape is removed, and that noise does not occur when it is re-attached.
8. When the source(s) of the wind noise is finally located, attach butyl tape, body sealer or similar material to obstruct this source as much as possible.

SPECIAL TOOLS

M1423000600531

TOOL	TOOL NUMBER AND NAME	SUPERSESSION	APPLICATION
<p>MB990900</p>	MB990900 or MB991164 Door adjusting wrench	MB990900-01	Adjustment of door fit
<p>MB990925AD</p>	MB990925 Bearing and oil seal installer set A: MB990939 Remover bar	MB990925-01 or General service tool	Adjustment of door striker
<p>MB990211</p>	MB990211 Slider hammer	MB990211-01	
<p>MB990241AC</p>	MB990241 Axle shaft puller A: MB990243 Body puller	MB990241-01 or General service tool	

TOOL	TOOL NUMBER AND NAME	SUPERSESION	APPLICATION
<p>A </p> <p>B </p> <p>C </p> <p>D  MB991223AZ</p>	<p>MB991223 Harness set A: MB991219 Test harness B: MB991220 LED harness C: MB991221 LED harness adapter D: MB991222 Probe</p>	<p>General service tools</p>	<p>Making voltage and resistance measurement during troubleshooting A: Connector pin contact pressure inspection B: Power circuit inspection C: Power circuit inspection D: Commercial tester connection</p>
<p> MB992006</p>	<p>MB992006 Extra fine probe</p>	<p>—</p>	<p>Making voltage and resistance measurement during troubleshooting</p>
<p>A  MB992051</p> <p>B  MB992052 MB992050AB</p>	<p>MB992050 Delta glass adjust block set A: MB992051 Delta glass adjust block A B: MB992052 Delta glass adjust block B</p>	<p>—</p>	<p>Adjustment of delta window glass</p>

TOOL	TOOL NUMBER AND NAME	SUPERSESION	APPLICATION
<p>C</p>  <p>MB992054</p> <p>D</p>  <p>MB992055</p> <p>E</p>  <p>MB992056</p> <p>F</p>  <p>MB992057 MB992053AB</p>	<p>MB992053 Door glass adjust block set</p> <p>C: MB992054 Door glass adjust block C</p> <p>D: MB992055 Door glass adjust block D</p> <p>E: MB992056 Door glass adjust block E</p> <p>F: MB992057 Door glass adjust block F</p>	–	Adjustment of front door window glass

ON-VEHICLE SERVICE

FRONT DOOR FIT ADJUSTMENT

M1423001200042

Required Special Tools:

- MB990211: Slide Hammer
- MB990243: Body Puller
- MB990900 or MB991164: Door adjusting Wrench
- MB990939: Brass Bar

⚠ CAUTION

- **Attach protection tape to the fender and door edges where the hinge is installed.**
- **Do not rotate special tool MB991164 with a torque of over 98 N·m (72 ft-lb).**

1. Use special tool MB990900 or MB991164 to loosen the hinge mounting bolts on the body side, and then adjust the clearance around the door so that it is uniform on all sides.
2. If a door is not flush with its surrounding panels, loosen the door-side door hinge mounting bolts and adjust the door as necessary.

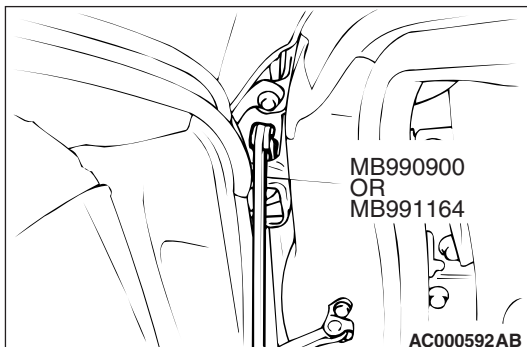

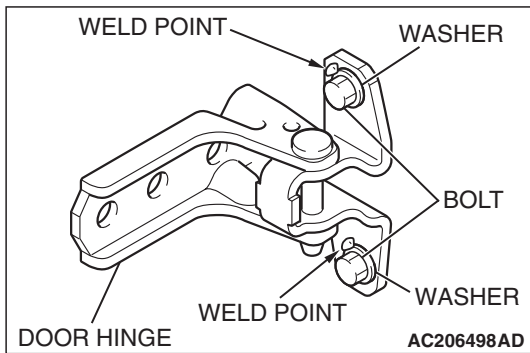

NOTE: If the door hinge mounting bolt washers are welded, grind off the welding according to the procedure below beforehand.

1. Remove the door hinge. (Refer [P.42-68.](#))
2. Use a chisel or grinder to release the door hinge mounting bolt washer, which is welded to the door hinge.
3. On completion, paint the affected area with touch-up paint to prevent corrosion.
4. Install the door hinge. (Refer [P.42-68.](#))

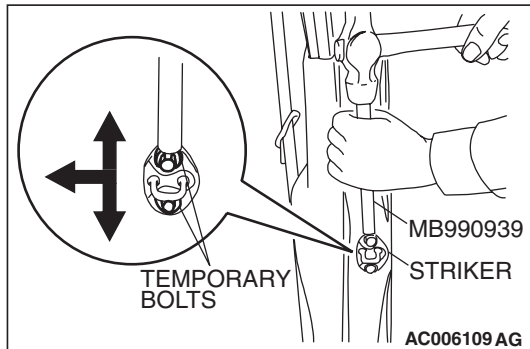

3. If the door is stiff to lock and unlock:

- (1) Adjust the striker (vertically or toward the inside of the vehicle)

Install a temporary bolt instead of the striker mounting bolt, and use special tool MB990939 and a hammer to tap the bolt in the desired direction.

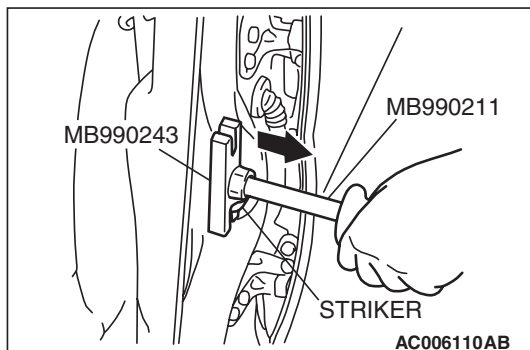

- (2) Adjust the striker (toward the outside of the vehicle)

Use special tools MB990211 and MB990243 to pull the striker toward the outside of the vehicle.

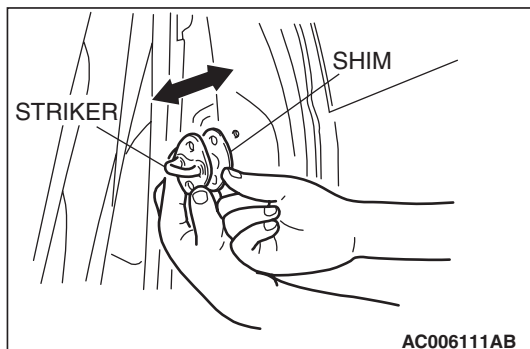

- (3) Adjust by using shims (forward and rearward)

Increase or decrease the number of shims so that the striker engages with the door latch properly.

DOOR WINDOW GLASS ADJUSTMENT

M1423001000521

Required Special Tools:

- MB992050: Delta glass adjust block set
 - MB992051: Delta glass adjust block A
 - MB992052: Delta glass adjust block B
- MB992053: Door glass adjust set
 - MB992054: Door glass adjust block C
 - MB992055: Door glass adjust block D
 - MB992056: Door glass adjust block E
 - MB992057: Door glass adjust block F

1. Remove the door trim (Refer to GROUP 52A, Door Trim [P.52A-34](#)).
2. Remove the door drip weatherstrip (Refer to [P.42-78](#)).
3. Install special tools MB992050 and MB992053 beside the mounting hole of the door window weatherstrip holder.
4. Close the door window glass fully.

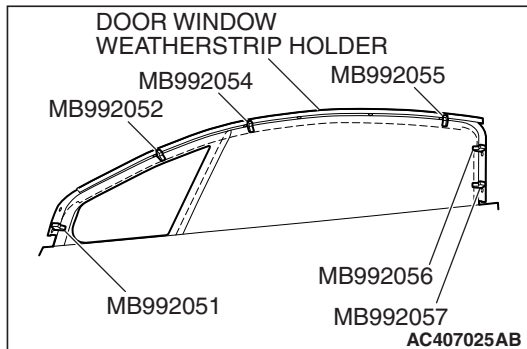

5. Adjust the position of the delta window glass in the fore/aft direction and the vertical direction.
 - (1) Loosen the delta window glass mounting bolts and nut.

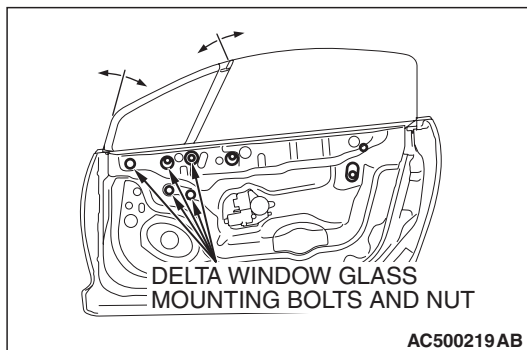

UNITS: mm (in)

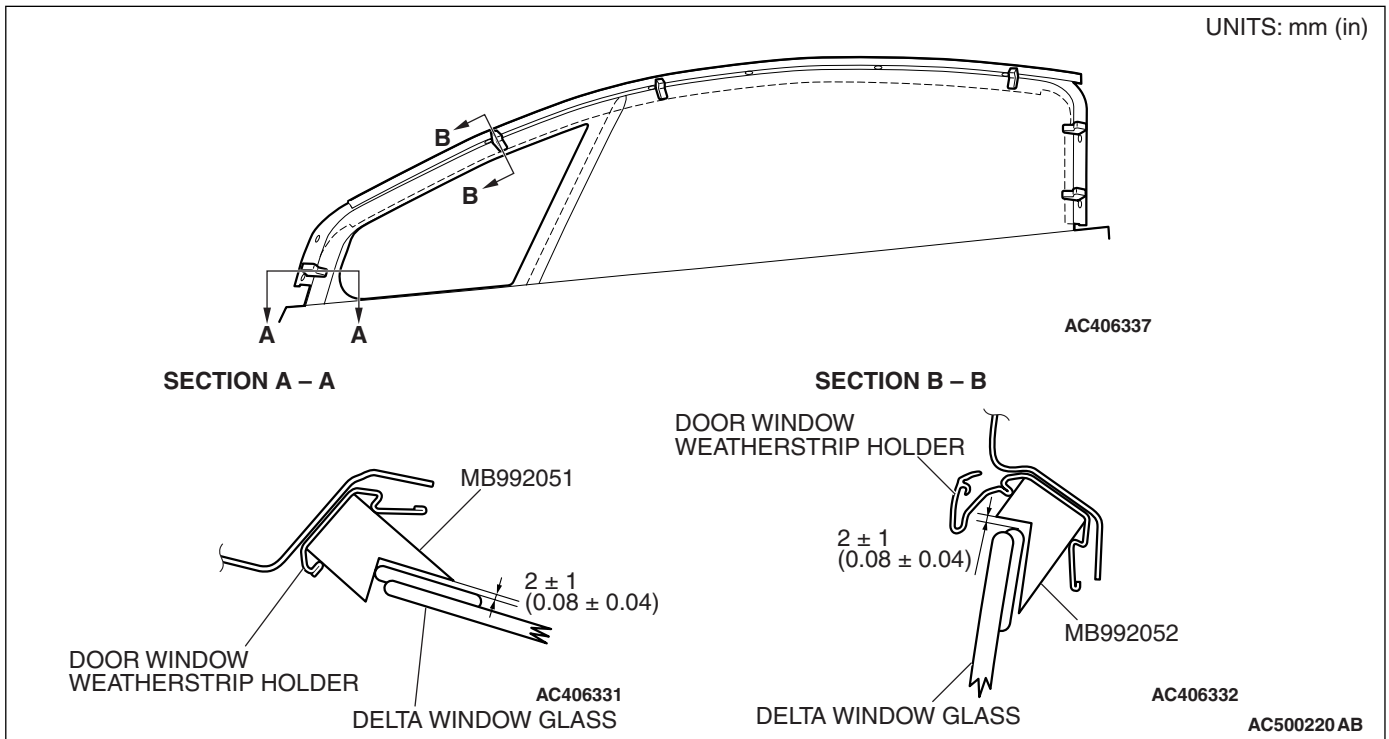

- (2) Adjust the delta window glass to the position shown by moving them in the fore/aft direction the vertical direction.
- (3) Tighten the delta window glass mounting bolts and nut.

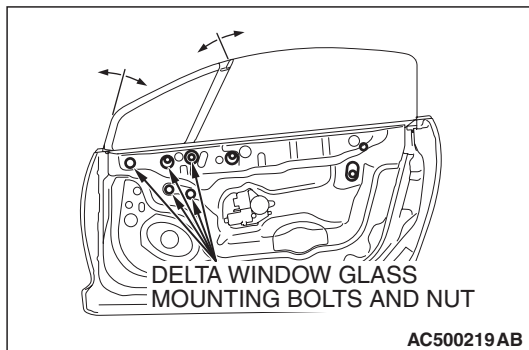

6. Adjust the tilt angle of the delta window glass.

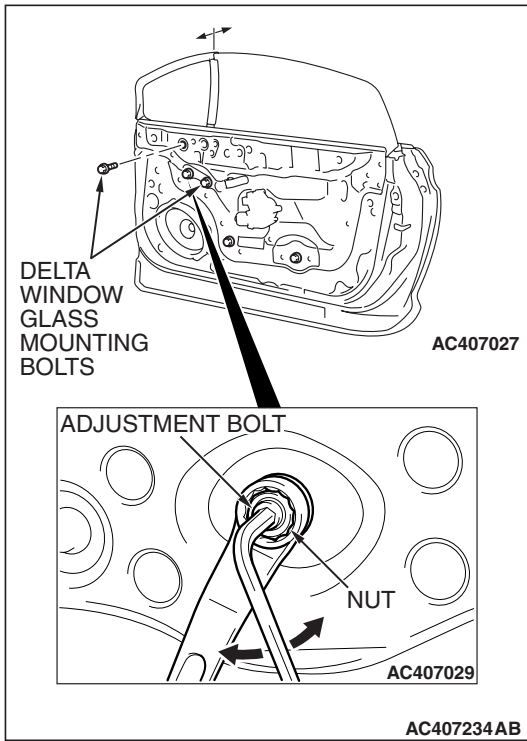

- (1) Loosen the delta window glass mounting bolts and nut.
- (2) Turn the adjustment bolt. The tilting direction of the delta window glass is altered by approximately 2 mm (0.08 inch) when turning the adjustment bolt one rotation.

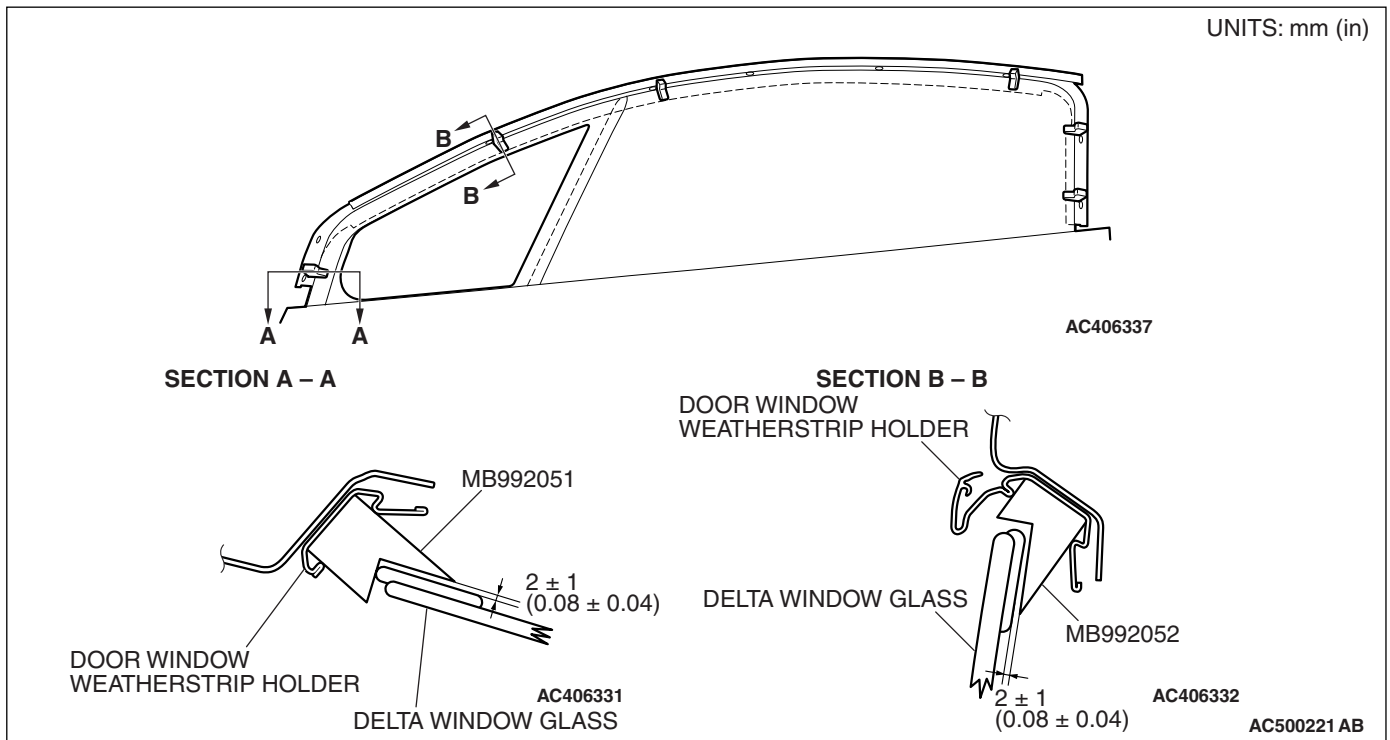

- (3) Adjust tilt angle of the delta window glass as shown.
- (4) Tighten the delta window glass mounting bolts and nuts.
7. Adjust the position of the door window glass in the fore/aft direction and the vertical direction.

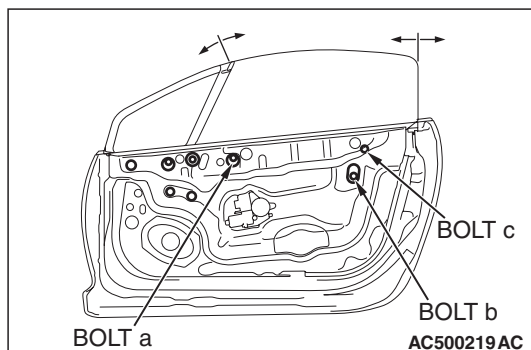

- (1) Loosen door window glass mounting bolts a, b, and c as follows:
 - a. Loosen bolt a and bolt b with the door window glass fully closed.
 - b. Lower the door window glass to the position that bolt c can be seen at the hole where bolt b was loosened.
 - c. Loosen bolt c.

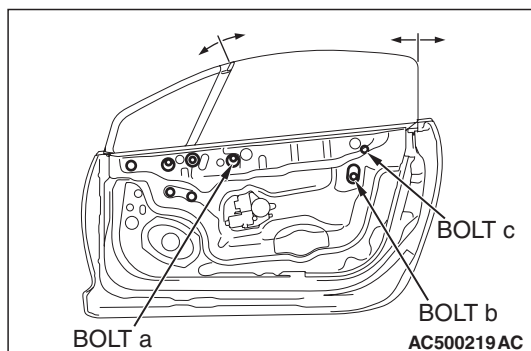
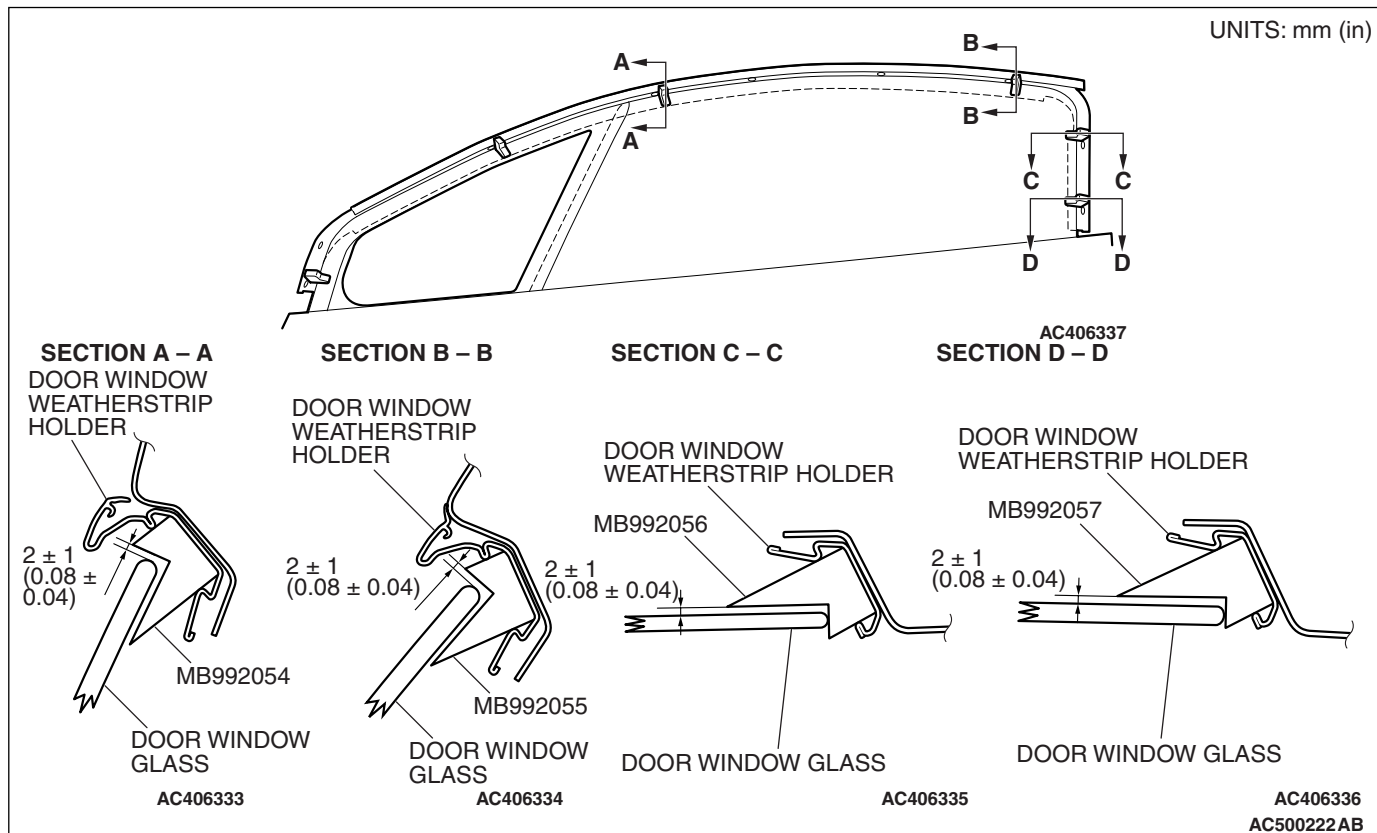

- (2) Adjust the door window glass to the position shown by moving them in the fore/aft direction the vertical direction.
- (3) Tighten door window glass mounting bolts a, b, and c as follows:
 - a. Temporarily tighten bolt a and bolt b with the door window glass fully closed.
 - b. Lower the door window glass to the installation position of bolt c.
 - c. Tighten bolt c.
 - d. Tighten bolt a and bolt b with the door window glass fully closed.

8. Adjust the tilt angle of the door window glass.

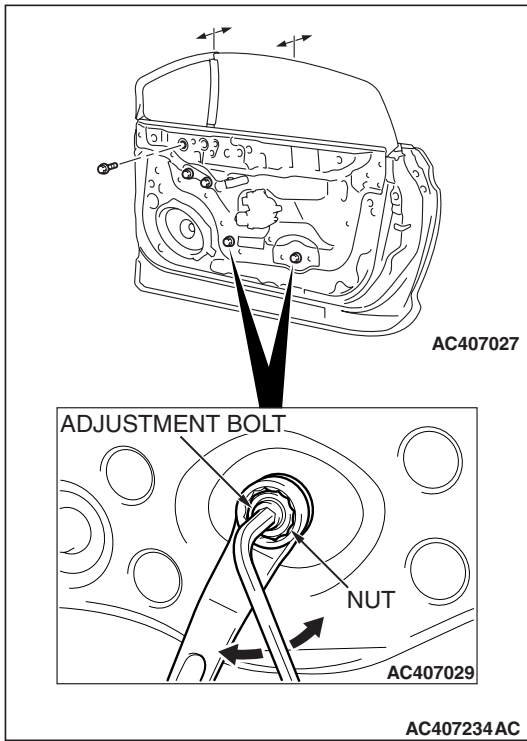

- (1) Loosen the door window glass mounting nuts.
- (2) Turn the adjustment bolt. The tilting direction of the door window glass is altered by approximately 1 mm (0.04 inch) when turning the adjustment bolt one rotation.

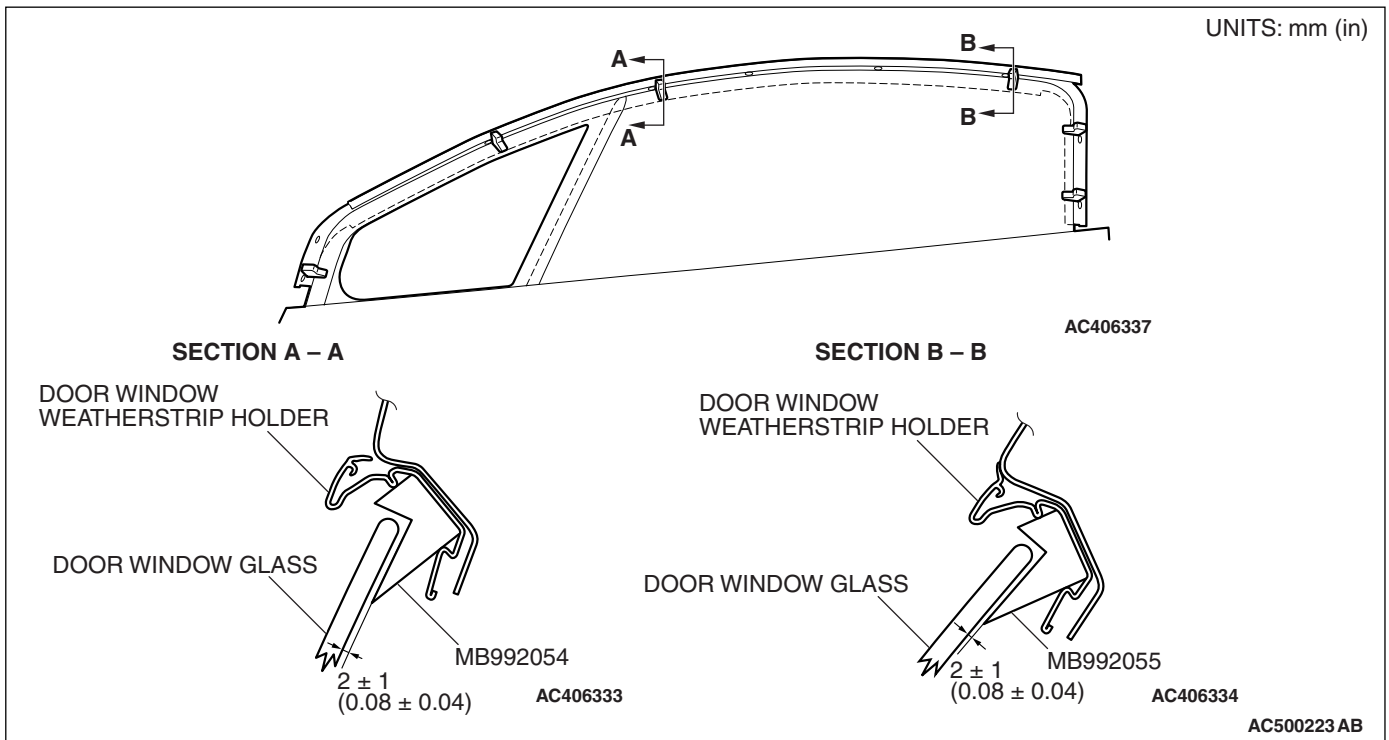

- (3) Adjust tilt angle of the door window glass as shown.
 - (4) Tighten the door window glass mounting nuts.
9. Adjust the position of the door window glass in the vertical direction.
- (1) Lower the door window glass to the fully open position.

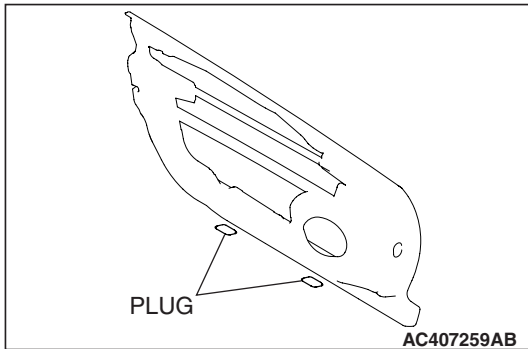

(2) Remove the plugs.

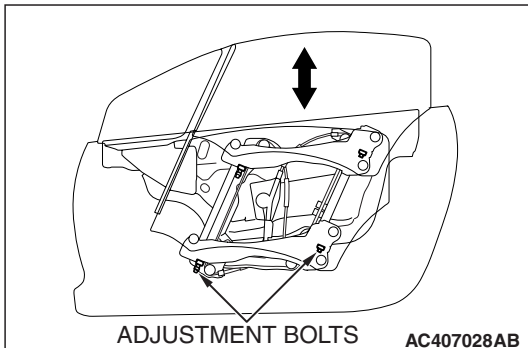

(3) Turn the adjustment bolts with an E-shape torque wrench (size: Q6E6). The height of the door window glass is altered by approximately 1 mm (0.04 inch) when turning the adjustment bolt one rotation.

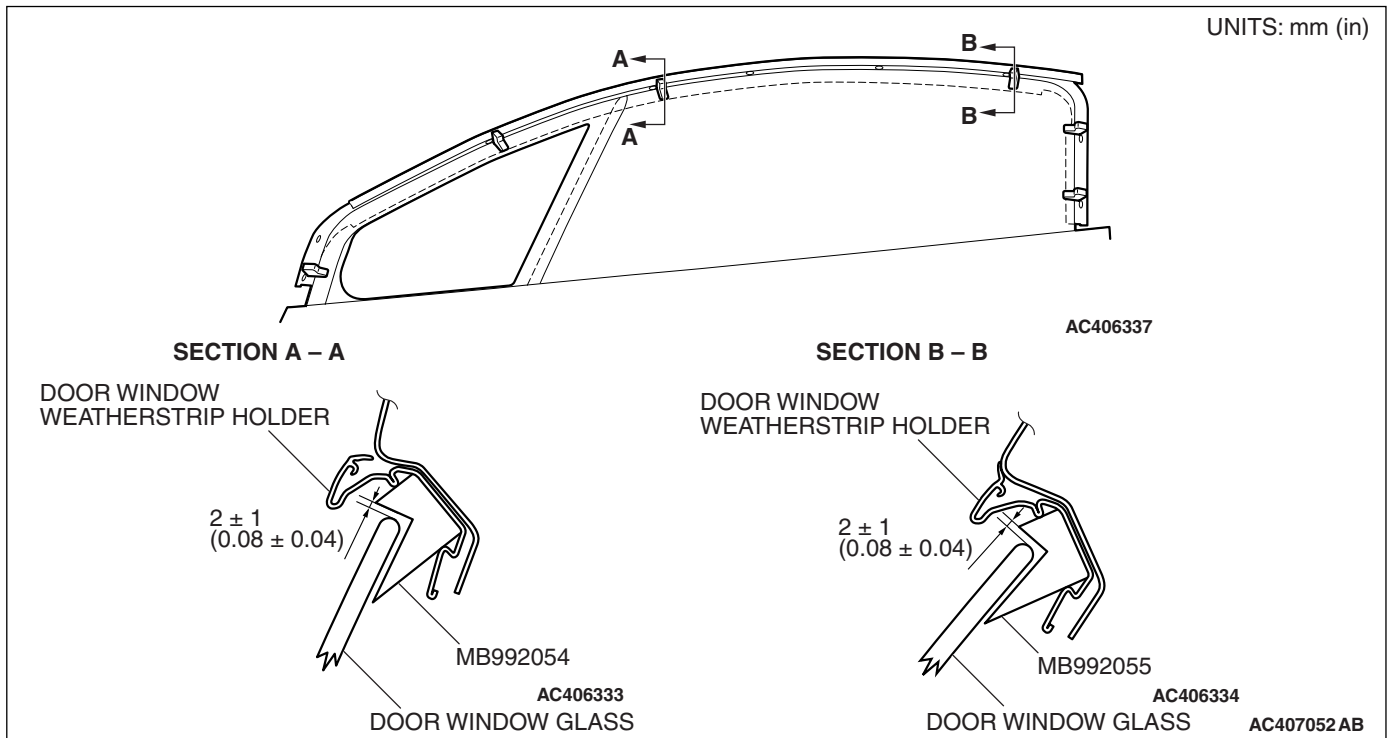

(4) Adjust the position of the door window glass in the vertical direction as shown.

(5) Install the plugs.

10. Remove special tools MB992050 and MB992053.

11. Install the door drip weatherstrip (Refer to P.42-78).

12. After adjustment, check that the following operations work normally.

- Power window
- Opening/closing of the doors
- Short stroke mechanism

13. Install the door trim (Refer to GROUP 52A, Door Trim P.52A-34).

POWER WINDOW TIMER FUNCTION CHECK

M1429004300314

After the doors are closed and the ignition switch is turned to the "LOCK" (OFF) position, the power windows should work within 30 seconds. The timer expires if the front door is opened during that 30 seconds. If it does not, carry out the timer troubleshooting in GROUP 54B, Diagnosis P.54B-57.

POWER WINDOW OPERATING CURRENT CHECK

M1429001100429

1. Remove the power window fuse and connect an ammeter as shown in the illustration.
2. When the power window switch is pressed in the "UP" position, a large amount of current flows from the time the window starts to close until it is fully closed, Measure the current during this time

Standard value (A): 5 ± 1A [Power supply voltage 14.5 ± 0.5V, 25° C (77° F)]

3. If not within the standard value, check the moving parts of the door window glass in the door window module assembly (Refer to P.42-70).

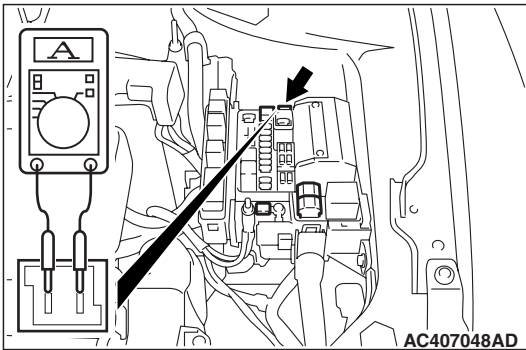

POWER WINDOW RELAY CHECK

M1429001800343

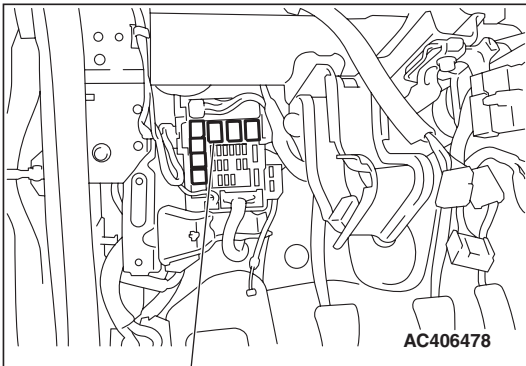

POWER WINDOW RELAY

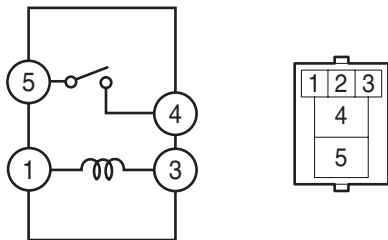

AC407056AC

BATTERY VOLTAGE	TESTER CONNECTION	SPECIFIED CONDITION
Not applied	4 - 5	Open circuit
<ul style="list-style-type: none"> • Connect terminal No. 3 and the negative battery terminal. • Connect terminal No. 1 and the positive battery terminal. 	4 - 5	Less than 2 ohms

POWER WINDOW CHECK

M1429004400452

1. Operate the power window switch of each door to verify that the power windows operate properly. If they don't, then troubleshoot as described in GROUP 54B, Diagnosis [P.54B-57](#).
2. Turn ON the power window lock switch of the power window main switch. Then operate the passenger's door power window sub-switch to ensure that they do not operate. If they do, replace the power window main switch (Refer to GROUP 52A, Door Trim [P.52A-35](#)).

SHORT STROKE MECHANISM FULLY CLOSED POSITION LEARNING PROCEDURE

M1429005500010

Close the door, and fully close the door window glass using the power window switch. After closing the door window glass fully, release the switch once. Then, press and hold the switch to fully close the door window glass again for 1 second.

CENTRAL DOOR LOCKING SYSTEM INSPECTION

M1427001100393

Check the following. Troubleshoot if operations malfunction (Refer to GROUP 54B, Diagnosis [P.54B-57](#)).

- Insert the key into the driver's key cylinder and turn once to the unlock side to unlock the driver's door. Turn the key once again to the unlock side to unlock all doors and liftgate.
- All doors and liftgate can be locked using the door lock switch built into the front power window (main or sub) switch.

FORGOTTEN KEY PREVENTION FUNCTION CHECK

M1427004700015

Check that the doors cannot be locked even if they are closed while the key is inserted to the ignition switch. Carry out troubleshooting if the doors can be locked. Refer to GROUP 54B, Diagnosis [P.54B-57](#).

DOOR OUTSIDE HANDLE PLAY CHECK

M1423001600459

1. Check that the door outside handle play is within the standard value range.

Standard value (B): 63.5 mm (2.5 inches)

2. If the door outside handle play is not within the standard value range, check the door outside handle or the door latch assembly. Replace if necessary.

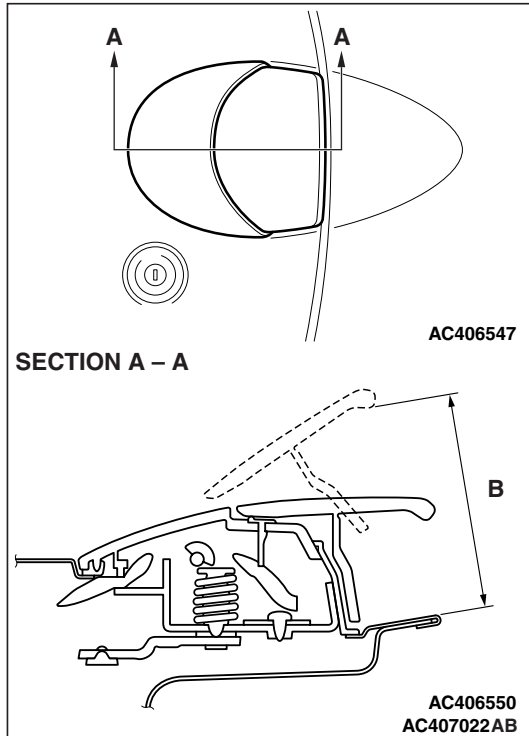
**DOOR INSIDE HANDLE PLAY CHECK**

M1423009400039

DOOR INSIDE HANDLE KNOB PLAY CHECK

1. Check that the door inside handle play is within the standard value range.

Standard value (B): 73.6 mm (2.90 inches)

2. If the door inside handle play is not within the standard value range, check the door inside handle or the inside handle cable. Replace if necessary.

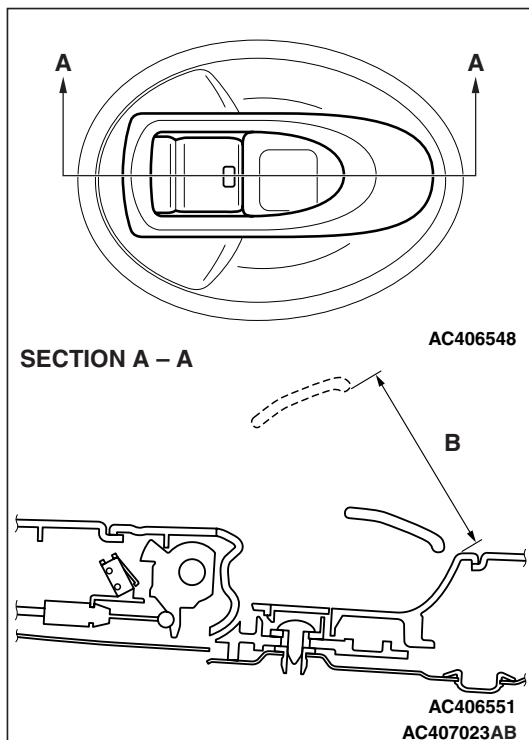

DOOR INSIDE HANDLE LOCK KNOB STROKE CHECK

1. Remove the door trim assembly (Refer to GROUP 52A, Door Trim P.52A-34).
2. Check that the door inside handle lock knob stroke is within the standard value.

Standard value (B): 14.9 ± 0.5 mm (0.59 ± 0.020 inch)

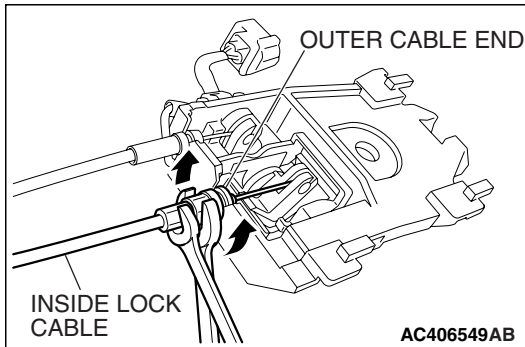
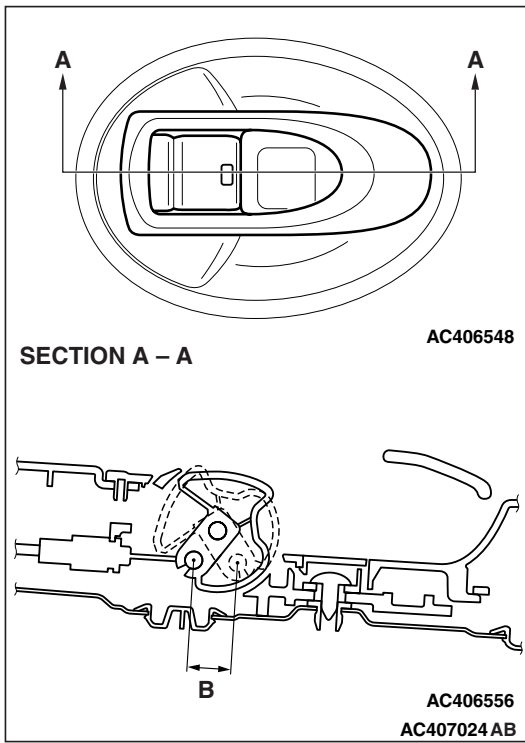

3. If not within the standard value, adjust the inside handle lock knob stroke with the outer cable end connecting the inside handle lock knob and inside lock cable.

**DOOR ASSEMBLY
REMOVAL AND INSTALLATION**

M1423002200454

Post-installation Operation

- Front Door Fit Adjustment (Refer to P.42-56).

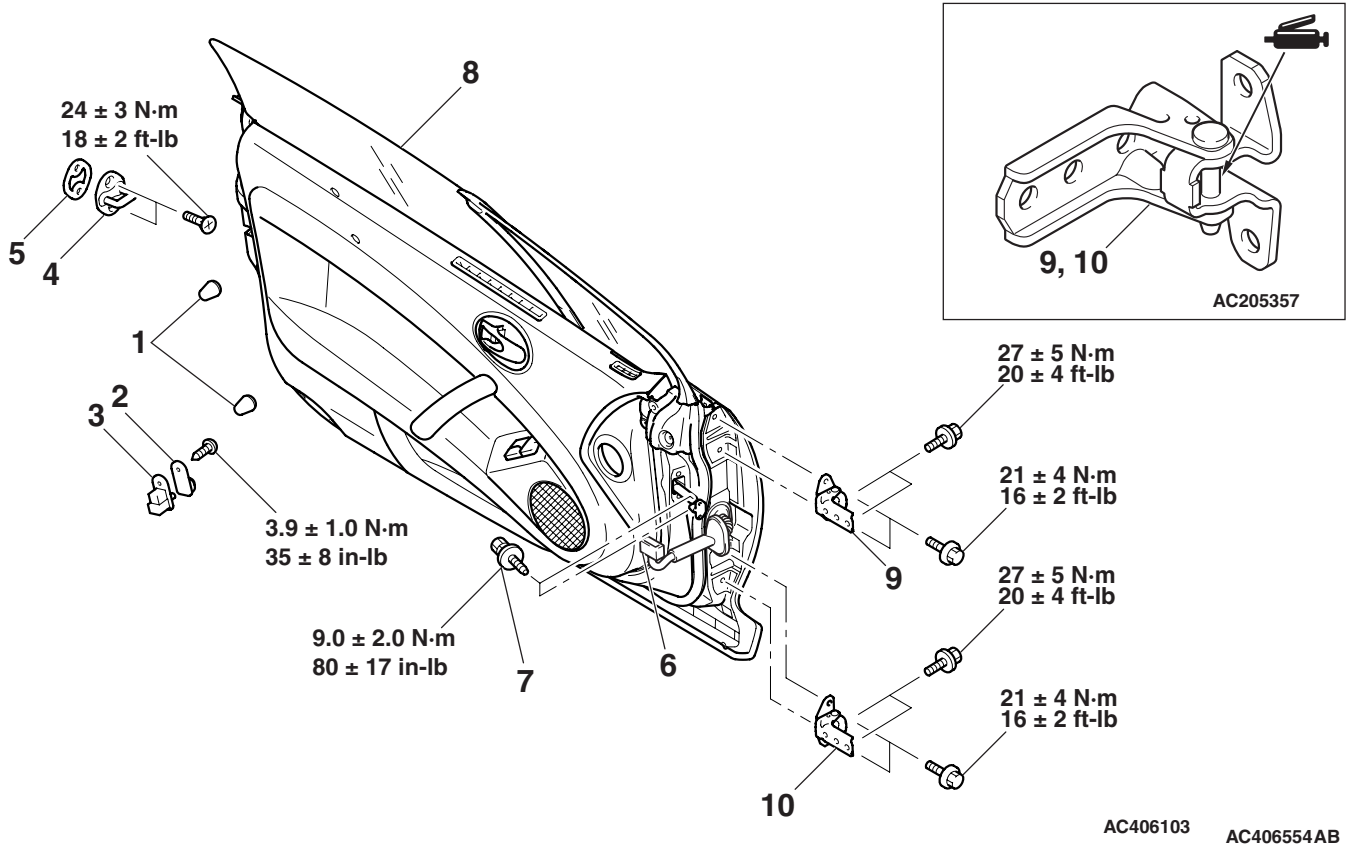

AC406103 AC406554AB

REMOVAL

1. DAMPER
- DOOR SWITCH REMOVAL STEPS**
2. DOOR SWITCH COVER
3. DOOR SWITCH

STRIKER REMOVAL STEPS

- >>A<<
4. STRIKER
 5. STRIKER SHIM

DOOR ASSEMBLY REMOVAL STEPS

- COWL SIDE TRIM (REFER TO GROUP 52A, TRIMS P.52A-31.)
- 6. HARNESS CONNECTOR
- 7. DOOR CHECK MOUNTING BOLT
- 8. DOOR ASSEMBLY
- 9. DOOR UPPER HINGE
- 10. DOOR LOWER HINGE

INSTALLATION SERVICE POINT

>>A<< STRIKER INSTALLATION

Align the center of the striker and latch within ± 1.5 mm (0.06 inch), and install.

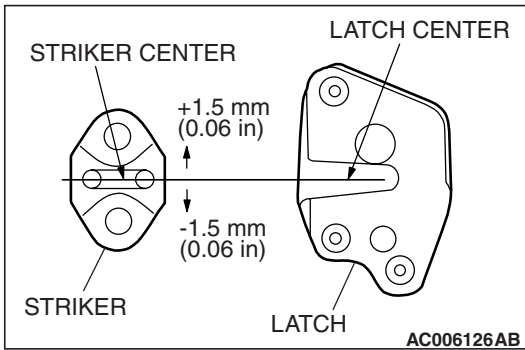

INSPECTION

M1423006000485

DOOR SWITCH CHECK

Check continuity between the switch terminals and body ground.

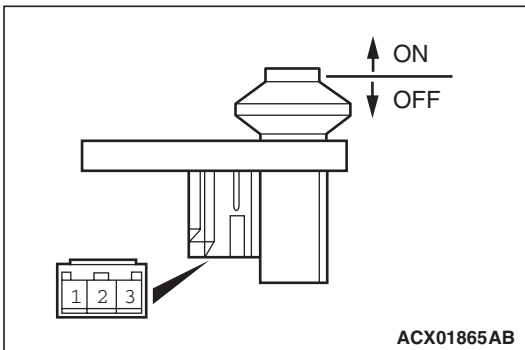

SWITCH POSITION	TESTER CONNECTION	SPECIFIED CONDITION
Released (ON)	2 –body ground	Less than 2 ohms
Depressed (OFF)	2 –body ground	Open circuit

**DOOR GLASS AND REGULATOR
REMOVAL AND INSTALLATION**

M1429001300649

Pre-removal Operation

- Door Trim Assembly Removal (Refer to GROUP 52A Door Trim P.52A-34).

Post-installation Operation

- Door Window Glass Adjustment (Refer to P.42-58).
- Door Trim Assembly Installation (Refer to GROUP 52A, Door Trim P.52A-34).
- Short Stroke Mechanism Fully Closed Position Learning Procedure (Refer to P.42-65).

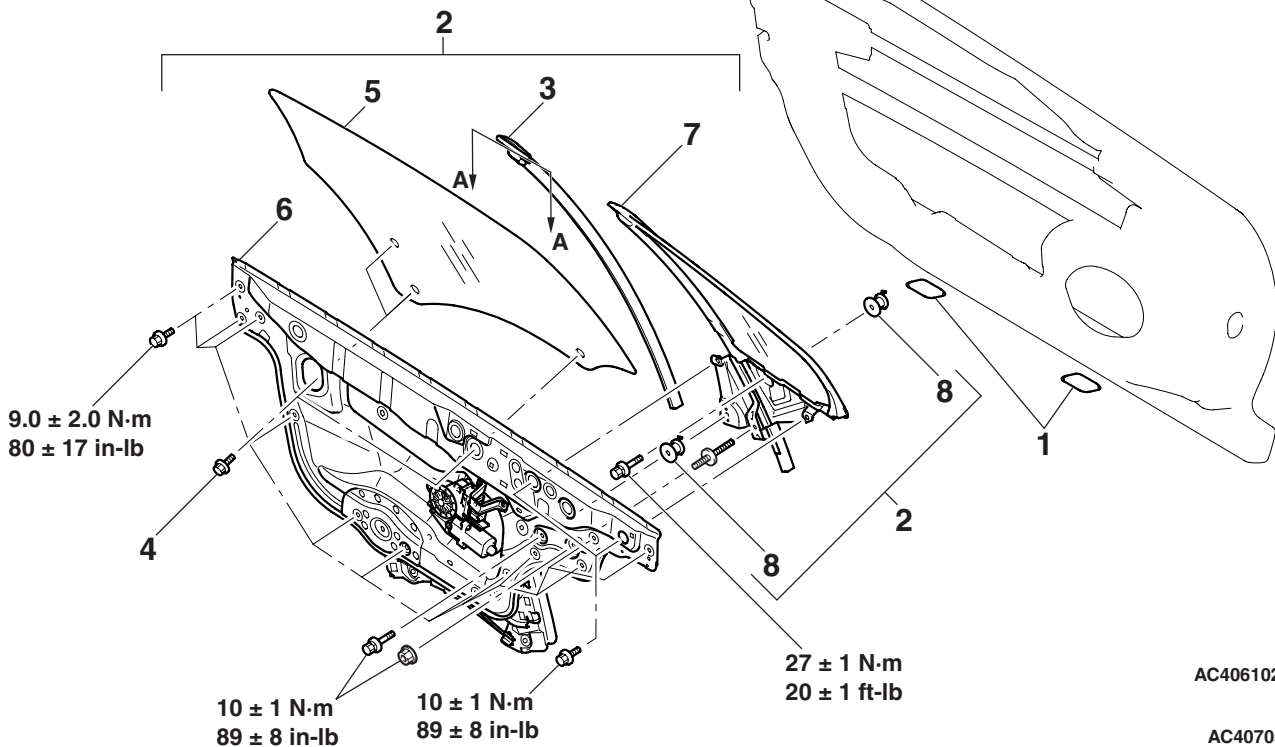
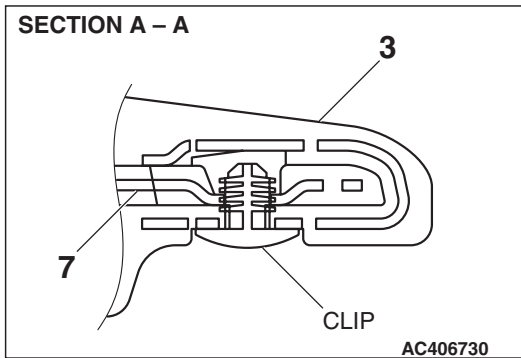

PLUG REMOVAL

1. PLUG

**DOOR WINDOW MODULE
ASSEMBLY REMOVAL**

- >>B<< 2. DOOR WINDOW MODULE ASSEMBLY

**DOOR WINDOW GLASS REMOVAL
STEPS**

- <<A>> >>A<< 3. RUNCHANNEL
- <<A>> >>A<< 4. DOOR WINDOW GLASS MOUNTING BOLT
5. DOOR WINDOW GLASS

**DOOR WINDOW MODULE
REMOVAL STEPS**

3. RUNCHANNEL
- <<A>> >>A<< 4. DOOR WINDOW GLASS MOUNTING BOLT
5. DOOR WINDOW GLASS
6. DOOR WINDOW MODULE
7. DELTA WINDOW GLASS
8. ADJUSTABLE NUT

REMOVAL SERVICE POINT

<<A>> DOOR WINDOW GLASS MOUNTING BOLT REMOVAL

⚠ CAUTION

When loosening the door window glass mounting bolts, use a magnetic wrench to prevent bolts from dropping into the door window module assembly cavity.

INSTALLATION SERVICE POINTS

>>A<< DOOR WINDOW GLASS MOUNTING BOLT INSTALLATION

⚠ CAUTION

When tightening the door window glass mounting bolts, use a magnetic wrench to prevent bolts from dropping into the door window module assembly cavity.

>>B<< DOOR WINDOW MODULE ASSEMBLY INSTALLATION

Install the door window module assembly in the order shown.

NOTE: Check the installation position of the door window glass and the delta window glass (Refer to P.42-58).

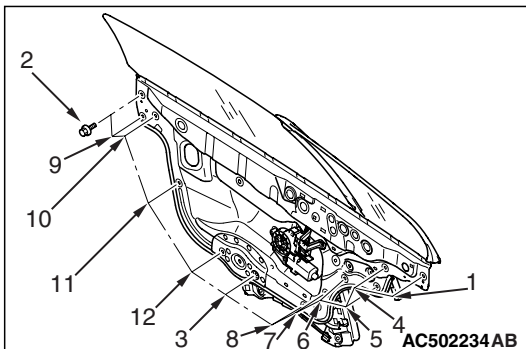

INSPECTION

M1429001400486

POWER WINDOW SWITCH CONTINUITY CHECK

Remove the power window switch (Refer to GROUP 52A, Door trim P.52A-35).

MAIN SWITCH

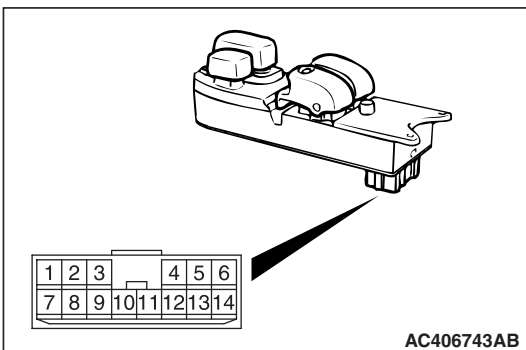

SWITCH POSITION		TESTER CONNECTION	SPECIFIED CONDITION
LH	UP	7 -12	Less than 2 ohms
	OFF	7 -12	Open circuit
	DOWN	7 -12	Less than 2 ohms
	AUTO DOWN	7 -12	Less than 2 ohms
RH	UP	9* -11	Less than 2 ohms
	OFF	9* -10, 9* -11	Open circuit
	DOWN	9* -10	Less than 2 ohms

*NOTE: *: Set the power window lock switch to UNLOCK position.*

SUB SWITCH

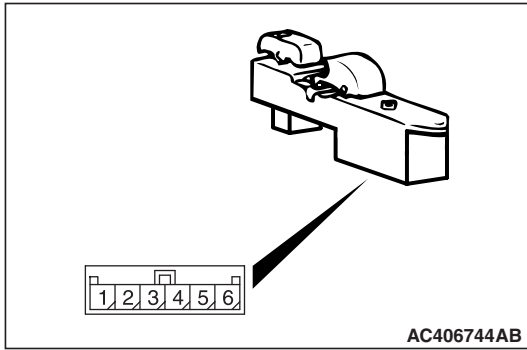

SWITCH POSITION	TESTER CONNECTION	SPECIFIED CONDITION
UP	3 – 5	Less than 2 ohms
OFF	3 – 5, 4 – 5	Open circuit
DOWN	4 – 5,	Less than 2 ohms

DOOR HANDLE AND LATCH
REMOVAL AND INSTALLATION

M1423004600641

CAUTION

- When the door lock key cylinder is replaced by key set of illustration <A>, register the encrypted code with the bar code on the ignition key in the key set. Refer to GROUP 54A, Encrypted Code Registration Criteria Table P.54A-13.

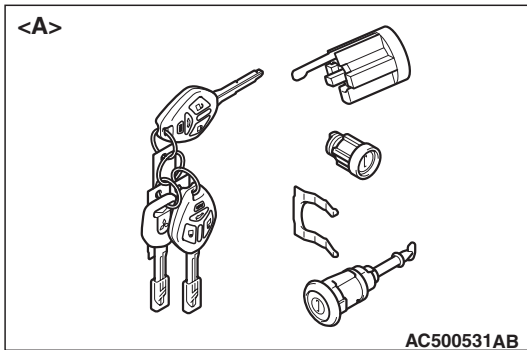

- When replacing by the door lock key cylinder of illustration , do not register the encrypted code with the bar code on the ignition key supplied simultaneously.

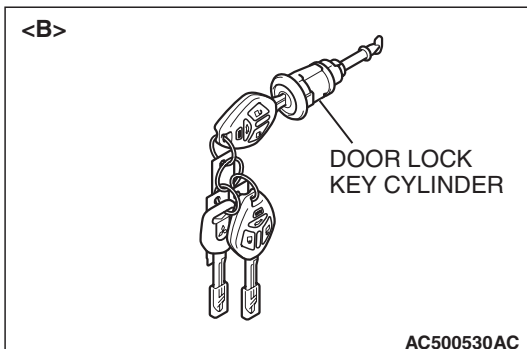

Pre-removal Operation

- Door Trim Assembly Removal (Refer to GROUP 52A Door Trim P.52A-34).

Post-installation Operation

- Door Inside Handle Play Check (Refer to P.42-66).
- Door Outside Handle Play Check (Refer to P.42-66).
- Door Trim Assembly Installation (Refer to GROUP 52A, Door Trim P.52A-34).

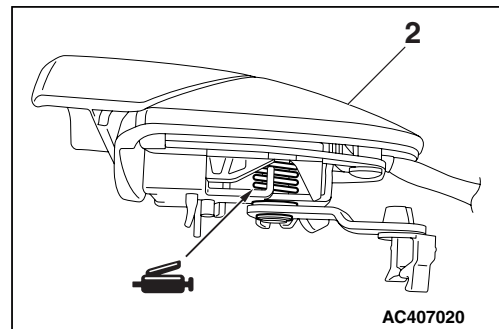
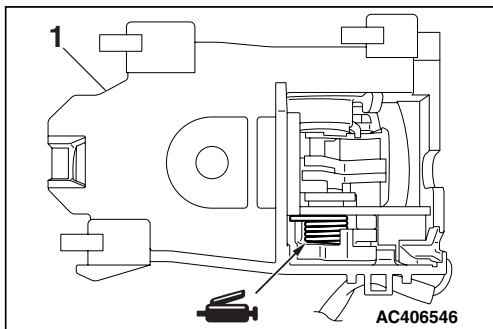
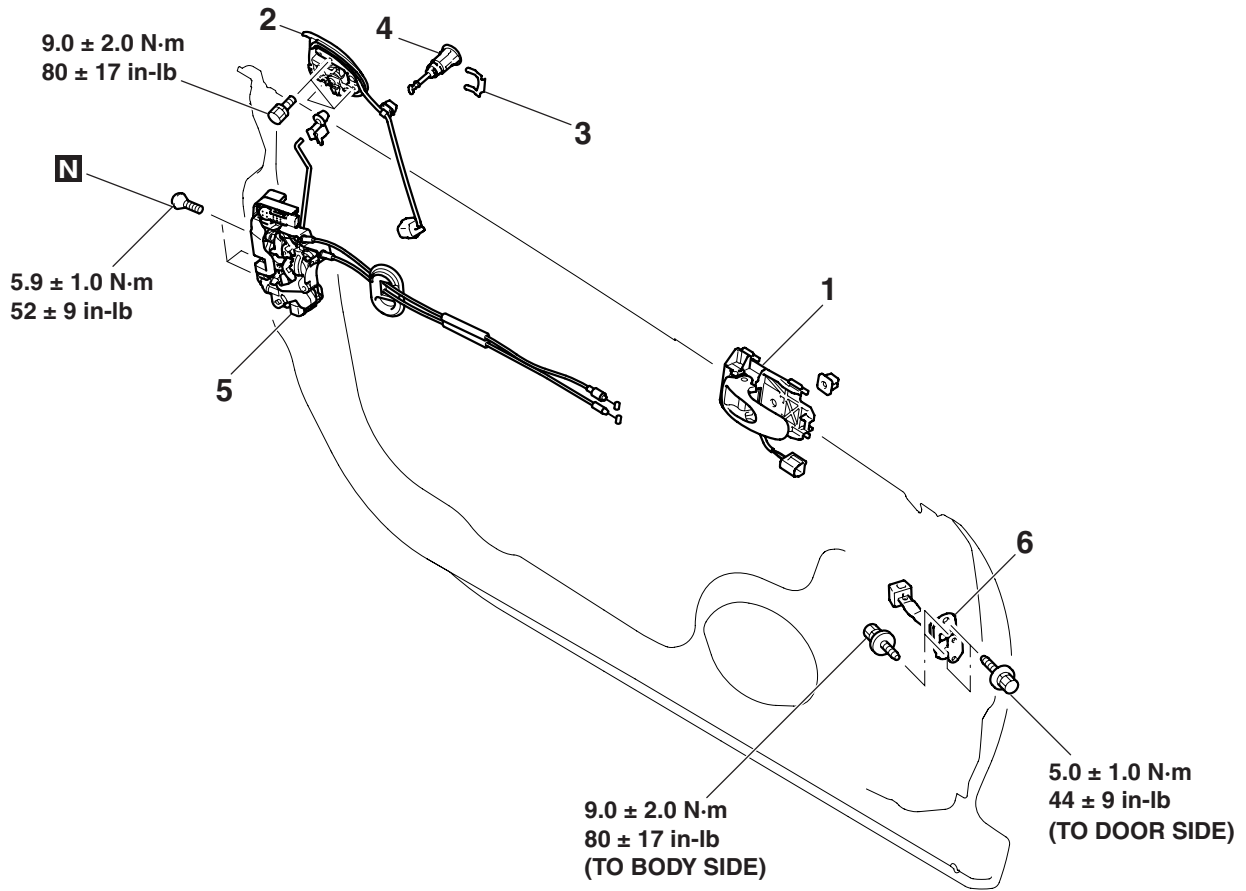

AC407021AB

DOOR INSIDE HANDLE REMOVAL

1. DOOR INSIDE HANDLE
- DOOR OUTSIDE HANDLE REMOVAL STEPS**
- DOOR WINDOW MODULE ASSEMBLY (REFER TO P.42-70.)
2. DOOR OUTSIDE HANDLE
- DOOR LOCK KEY CYLINDER AND DOOR LATCH ASSEMBLY REMOVAL STEPS**
- DOOR WINDOW MODULE ASSEMBLY (REFER TO P.42-70.)
3. RETAINER <DRIVER'S SIDE ONLY>
 4. DOOR LOCK KEY CYLINDER <DRIVER'S SIDE ONLY>
 5. DOOR LATCH ASSEMBLY
- DOOR CHECK REMOVAL STEPS**
- FRONT DOOR SPEAKER BRACKET (REFER TO GROUP 54A, SPEAKER P.54A-227.)

>>A<< 6. DOOR CHECK

Required Special Tool:

- MB991223: Harness Set

INSTALLATION SERVICE POINTS

>>A<< DOOR CHECK INSTALLATION

Install the door check so that the identification mark faces upwards.

ITEM	IDENTIFICATION MARK
Left door	P2FL
Right door	P2FR

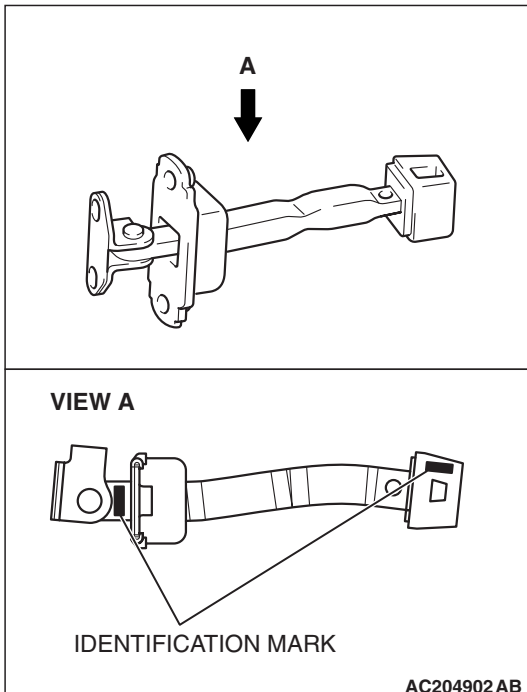

INSPECTION

M1423004700712

FRONT DOOR LATCH CHECK

The illustration shows when the door lock actuator is viewed from inside the door.

DOOR LOCK ACTUATOR CHECK <LEFT SIDE>

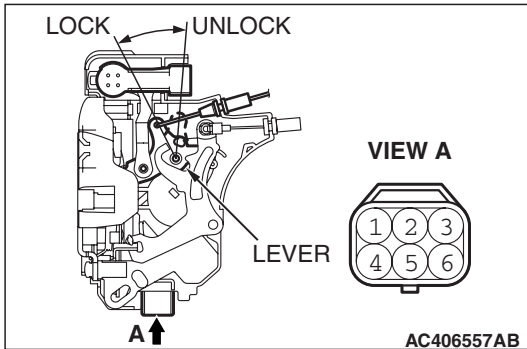

LEVER POSITION	BATTERY CONNECTION	LEVER OPERATION
At the "LOCK" position	<ul style="list-style-type: none"> Connect terminal No. 4 and the negative battery terminal. Connect terminal No. 6 and the positive battery terminal. 	The lever moves from the "LOCK" position to the "UNLOCK" position.
At the "UNLOCK" position	<ul style="list-style-type: none"> Connect terminal No. 6 and the negative battery terminal. Connect terminal No. 4 and the positive battery terminal. 	The lever moves from the "UNLOCK" position to the "LOCK" position.

DOOR LOCK ACTUATOR SWITCH CHECK <LEFT SIDE>

LEVER POSITION	TESTER CONNECTION	SPECIFIED CONDITION
At the "LOCK" position	1 – 3	Open circuit
At the "UNLOCK" position	1 – 3	Less than 2 ohms

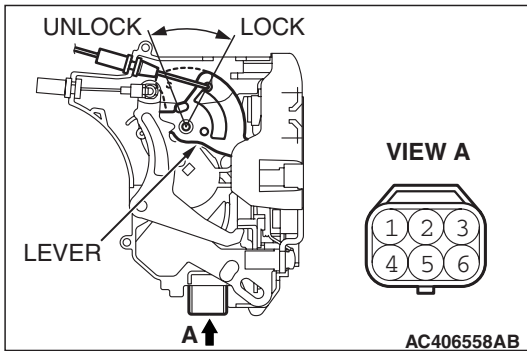

DOOR LOCK ACTUATOR CHECK <RIGHT SIDE>

LEVER POSITION	BATTERY CONNECTION	LEVER OPERATION
At the "LOCK" position	<ul style="list-style-type: none"> Connect terminal No. 4 and the negative battery terminal. Connect terminal No. 6 and the positive battery terminal. 	The lever moves from the "LOCK" position to the "UNLOCK" position.
At the "UNLOCK" position	<ul style="list-style-type: none"> Connect terminal No. 6 and the negative battery terminal. Connect terminal No. 4 and the positive battery terminal. 	The lever moves from the "UNLOCK" position to the "LOCK" position.

DOOR LOCK ACTUATOR SWITCH CHECK <RIGHT SIDE>

LEVER POSITION	TESTER CONNECTION	SPECIFIED CONDITION
At the "LOCK" position	1 – 3	Open circuit
At the "UNLOCK" position	1 – 3	Less than 2 ohms

DOOR LOCK KEY CYLINDER SWITCH CONTINUITY CHECK

Install the door lock key cylinder to the door latch assembly, and check the door lock key cylinder switch.

SWITCH POSITION	TESTER CONNECTION	SPECIFIED CONDITION
LOCK	1 – 3	Less than 2 ohms
NEUTRAL (OFF)	1 – 2, 2 – 3	Open circuit
UNLOCK	2 – 3	Less than 2 ohms

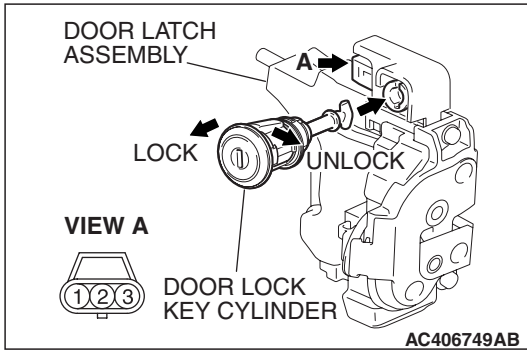

CENTRAL DOOR LOCK SWITCH CONTINUITY CHECK

Remove the power window switch (Refer to GROUP 52A, Door Trim P.52A-35).

<DRIVER'S SIDE>

SWITCH POSITION	TESTER CONNECTION	SPECIFIED CONDITION
LOCK	12 – 13	Less than 2 ohms
OFF	12 – 13, 12 – 14	Open circuit
UNLOCK	12 – 14	Less than 2 ohms

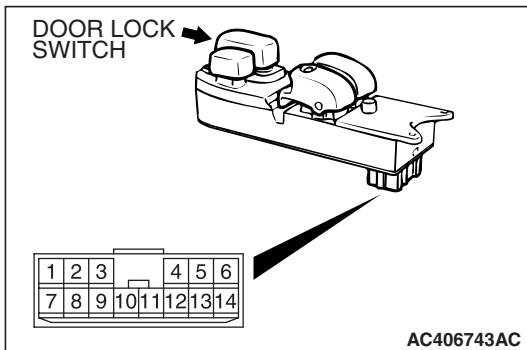

<PASSENGER'S SIDE>

SWITCH POSITION	TESTER CONNECTION	SPECIFIED CONDITION
LOCK	13 – 14	Less than 2 ohms
OFF	13 – 14, 12 – 14	Open circuit
UNLOCK	12 – 14	Less than 2 ohms

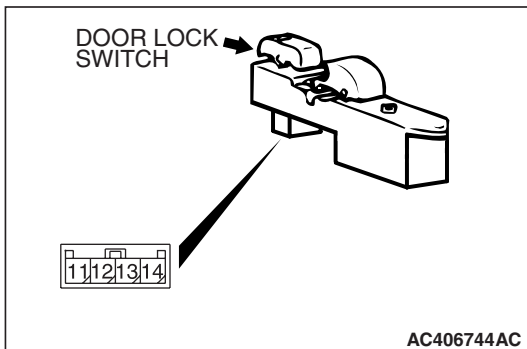

OUTSIDE HANDLE SWITCH CONTINUITY CHECK

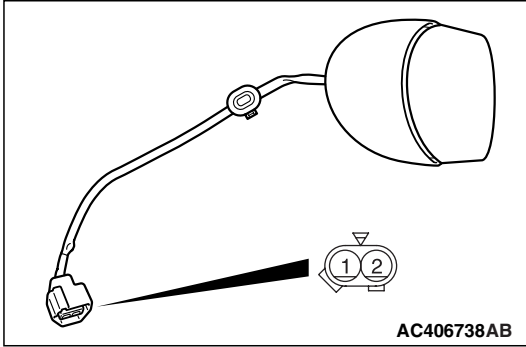

SWITCH POSITION	TESTER CONNECTION	SPECIFIED CONDITION
ON (OPEN)	1 -2	Less than 2 ohms
OFF (CLOSE)	1 -2	Open circuit

INSIDE HANDLE SWITCH CONTINUITY CHECK

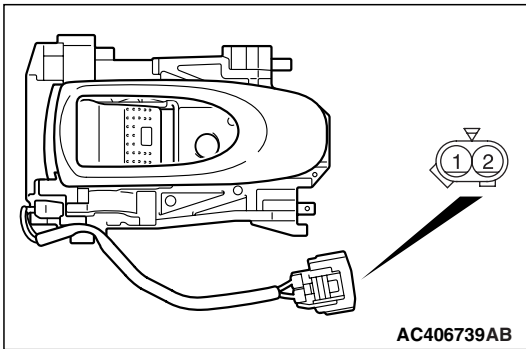

SWITCH POSITION	TESTER CONNECTION	SPECIFIED CONDITION
ON (OPEN)	1 -2	Less than 2 ohms
OFF (CLOSE)	1 -2	Open circuit

**WINDOW GLASS RUNCHANNEL AND DOOR OPENING WEATHERSTRIP
REMOVAL AND INSTALLATION**

M1423003100676

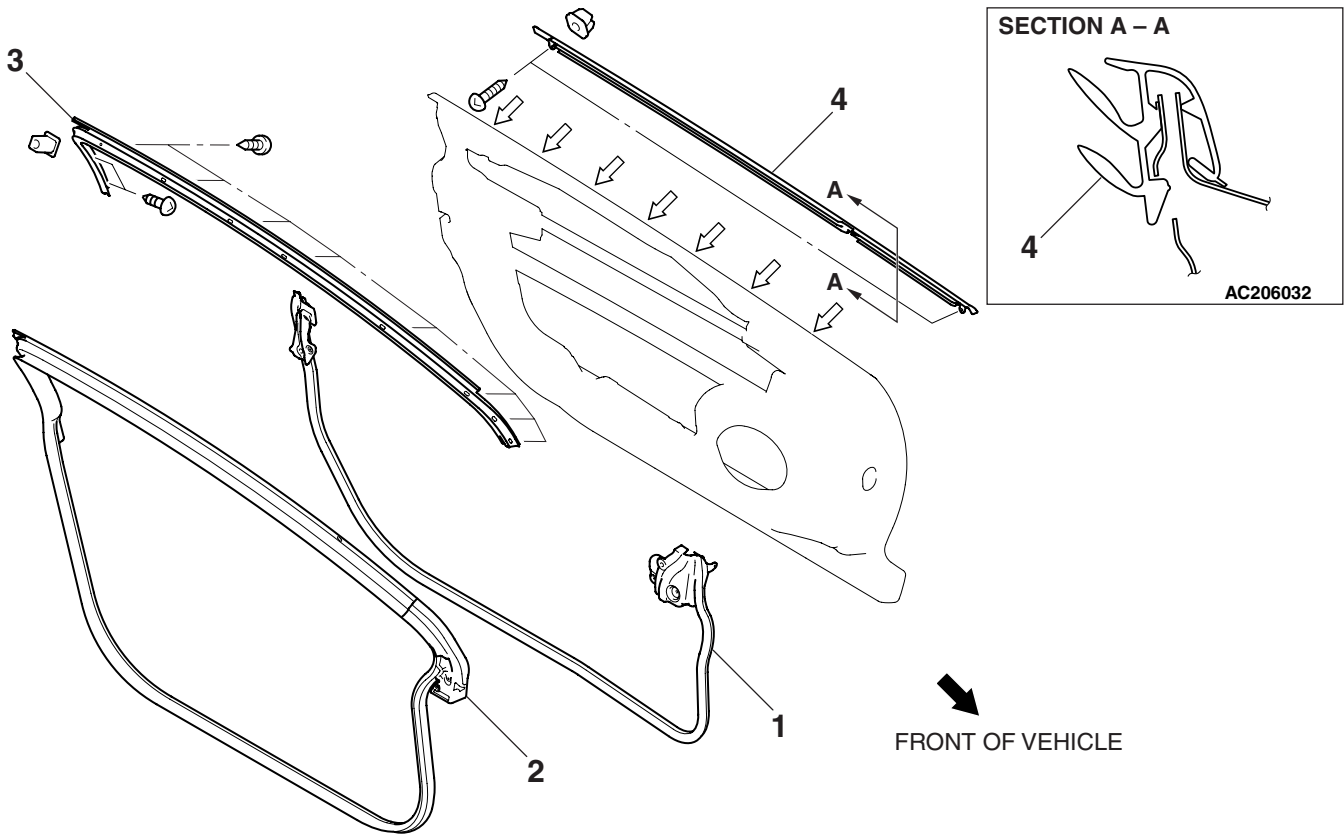

NOTE

↔ : THE CONVEX POSITIONS OF THE DOOR

AC406101

AC406559AB

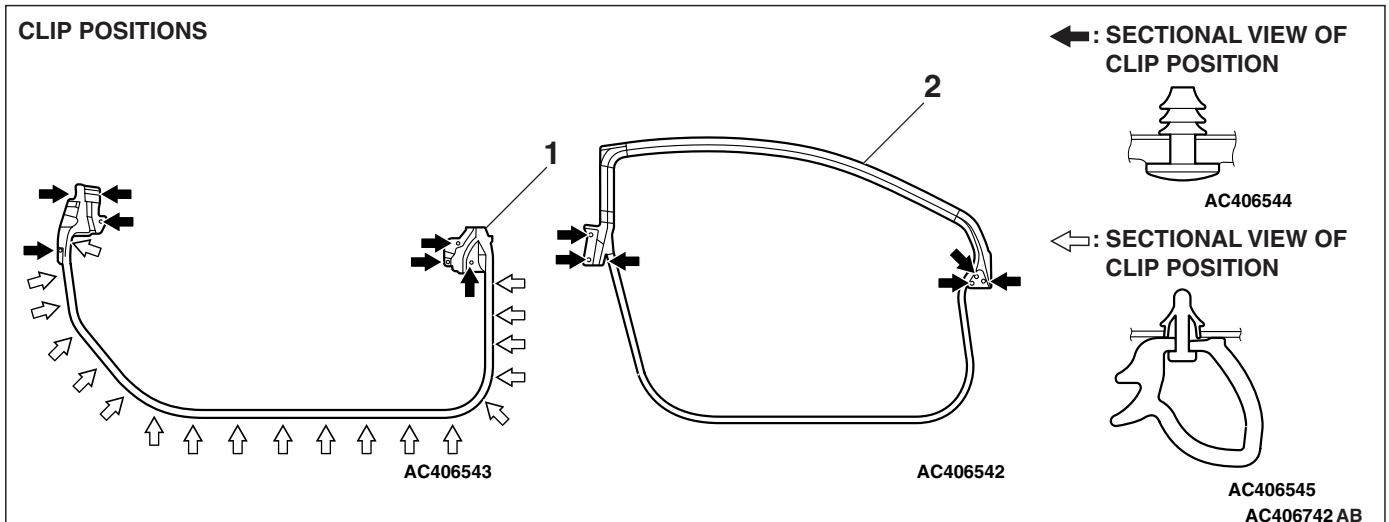

**DOOR OPENING WEATHERSTRIP
OUTER REMOVAL STEPS**

- DOOR TRIM ASSEMBLY (REFER TO GROUP 52A, DOOR TRIM P.52A-34.)

>>C<< 1. DOOR OPENING WEATHERSTRIP OUTER

**DOOR DRIP WEATHERSTRIP AND
DOOR WINDOW WEATHERSTRIP
HOLDER REMOVAL STEPS**

- FRONT SCUFF PLATE (REFER TO GROUP 52A, TRIMS P.52A-31.)
- >>B<< 2. DOOR DRIP WEATHERSTRIP
>>A<< 3. DOOR WINDOW WEATHERSTRIP HOLDER

**DOOR BELTLINE MOLDING
REMOVAL STEPS**

- DOOR TRIM ASSEMBLY (REFER TO GROUP 52A, DOOR TRIM P.52A-34).
- 4. DOOR BELTLINE MOLDING

INSTALLATION SERVICE POINTS

**>>A<< DOOR WINDOW WEATHERSTRIP
HOLDER INSTALLATION**

Install the door window weatherstrip holder in the sequence shown.

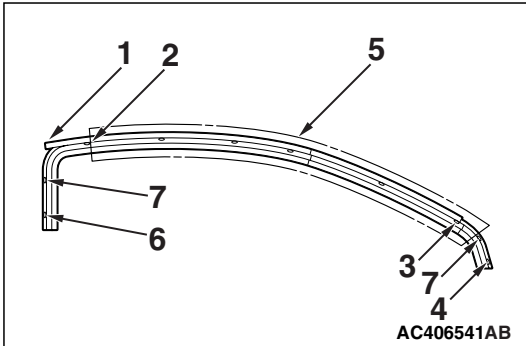

**>>B<< DOOR DRIP WEATHERSTRIP
INSTALLATION**

Install the door drip weatherstrip in the sequence shown. Apply a force in the arrowed direction shown and install the door drip weatherstrip.

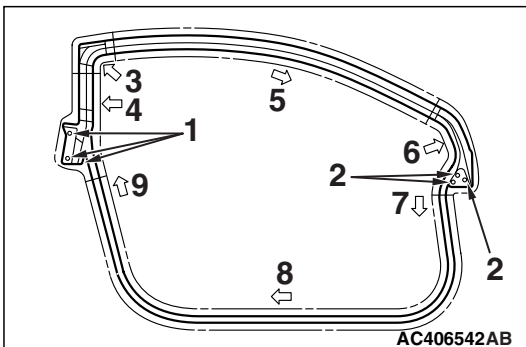

**>>C<< DOOR OPENING WEATHERSTRIP OUTER
INSTALLATION**

Install the door opening weatherstrip outer in the sequence shown.

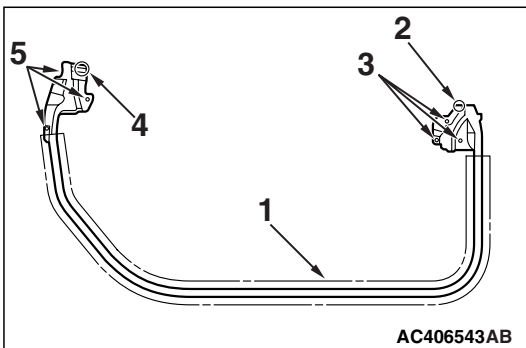

LIFTGATE

LIFTGATE DIAGNOSIS

INTRODUCTION TO LIFTGATE DIAGNOSIS

M1424002500135

Difficult locking/unlocking, uneven clearance, and wind noise from the liftgate may be due to improper adjustment of the liftgate.

LIFTGATE DIAGNOSTIC TROUBLESHOOTING STRATEGY

M1424002600143

Use these steps to plan your diagnostic strategy. If you follow them carefully, you will be sure that you have exhausted most of the possible ways to find a liftgate fault.

1. Gather information from the customer.

2. Verify that the condition described by the customer exists.
3. Find the malfunction by following the Symptom Chart.
4. Verify malfunction is eliminated.

SYMPTOM CHART

M1424002700151

SYMPTOM	INSPECTION PROCEDURE	REFERENCE PAGE
Difficult locking and unlocking	1	P.42-80
Uneven body clearance	2	P.42-81
Uneven height	3	P.42-81

SYMPTOM PROCEDURES

INSPECTION PROCEDURE 1: Difficult Locking and Unlocking

DIAGNOSIS

STEP 1. Check the release cable routing.

Q: Is the release cable routed correctly?

YES : Go to Step 3.

NO : Re-route the release cable. Then go to Step 2.

STEP 2. Check the engagement of the liftgate latch and liftgate striker.

Q: Are the liftgate latch and liftgate striker engaged correctly?

YES : Then go to Step 3.

NO : Align the liftgate latch and liftgate striker (Refer to [P.42-82](#)).

STEP 3. Retest the system.

Q: Does the liftgate lock operate easily?

YES : The procedure is complete.

NO : Return to Step 1.

INSPECTION PROCEDURE 2: Uneven Body Clearance

DIAGNOSIS

STEP 1. Check the clearance around the liftgate.

Q: Is the liftgate installed correctly?

YES : Go to Step 2.

NO : Adjust clearance around liftgate (Refer to [P.42-82](#)).

STEP 2. Retest the system.

Q: Is the clearance with the body even?

YES : The procedure is complete.

NO : Return to Step 1.

INSPECTION PROCEDURE 3: Uneven Height

DIAGNOSIS

STEP 1. Check the liftgate damper height.

Q: Is the liftgate damper height proper?

YES : Go to Step 2.

NO : Adjust the liftgate damper (Refer to [P.42-83](#)). Then go to Step2.

STEP 2. Retest the system.

Q: Are the liftgate and body height even?

YES : The procedure is complete.

NO : Return to Step 1.

SPECIAL TOOLS

M1424000600330

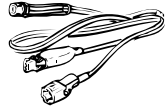
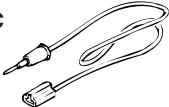
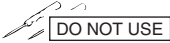
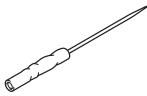
TOOL	TOOL NUMBER AND NAME	SUPERSESION	APPLICATION
<p>A</p>  <p>B</p>  <p>C</p>  <p>D</p>  <p>MB991223AZ</p>	<p>MB991223 Harness set</p> <p>A: MB991219 Test harness</p> <p>B: MB991220 LED harness</p> <p>C: MB991221 LED harness adapter</p> <p>D: MB991222 Probe</p>	<p>General service tools</p>	<p>Measurement of terminal voltage and resistance</p> <p>A: Connector pin contact pressure inspection</p> <p>B: Power circuit inspection</p> <p>C: Power circuit inspection</p> <p>D: Commercial tester connection</p>
 <p>MB992006</p>	<p>MB992006 Extra fine probe</p>	<p>–</p>	<p>Measurement of terminal voltage and resistance</p>

ON-VEHICLE SERVICE**ADJUSTMENT OF CLEARANCE AROUND
LIFTGATE**

M1424003900028

Remove the headlining (Refer to GROUP 52A, HEADLINING P.52A-37), and loosen the liftgate hinge mounting nuts at body side. Then adjust the liftgate to align properly.

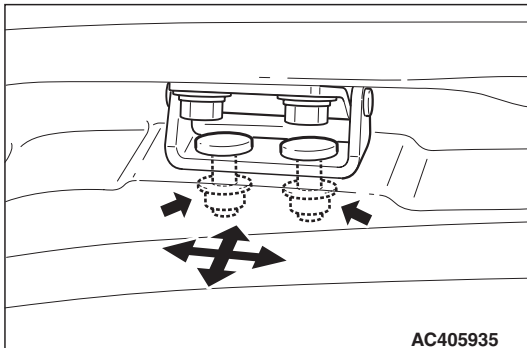
**ALIGNMENT OF LIFTGATE LATCH AND
LIFTGATE STRIKER**

M1424003800021

Remove the rear end trim (Refer to GROUP 52A, Trims P.52A-31). Then, loosen the liftgate latch mounting bolts and adjust the liftgate latch.

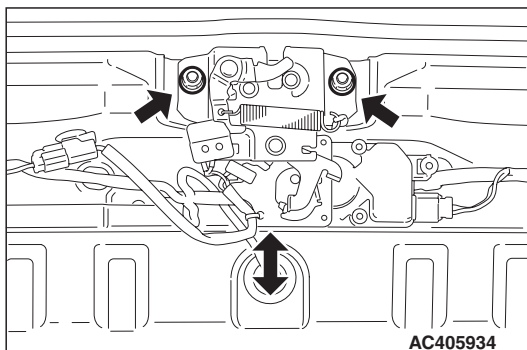

ADJUSTMENT OF LIFTGATE HEIGHT

M1424003500194

Turn the liftgate damper until the liftgate height is as shown. If the liftgate height is still not even at left and right sides, turn the liftgate damper further until the liftgate height is even. The liftgate damper height is altered by roughly 3 mm (0.1 inch) when turning the liftgate damper one rotation.

NOTE: If a rattling noise (clack) is caused by the vibration of the liftgate while driving, adjust the liftgate damper height so that the liftgate damper contacts the body securely.

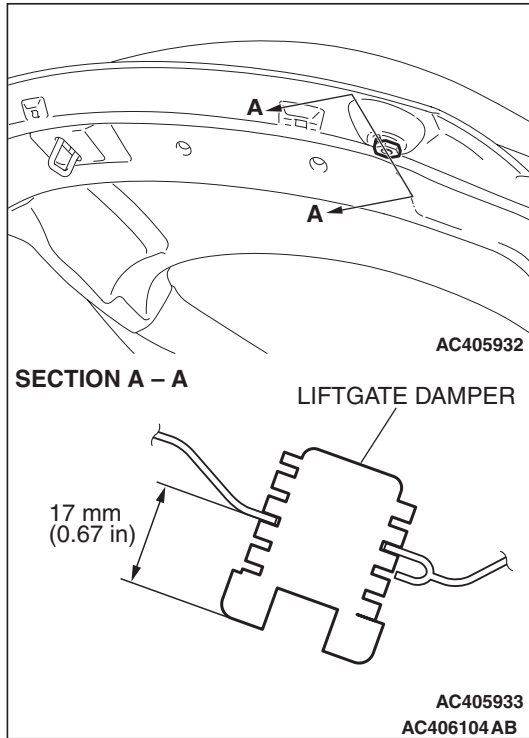

LIFTGATE

REMOVAL AND INSTALLATION

M1424001100413

CAUTION

- Do not disassemble or throw the liftgate gas spring into fire.
- Punch a hole in the gas spring before disposal to release the gas inside.
- Ensure the liftgate gas spring piston rod does not come into contact with foreign material.

Pre-removal Operation

- Liftgate Trim Assembly Removal (Refer to GROUP 52A, Liftgate Trim P.52A-36).
- Rear Wiper Motor and Rear Washer Hose Removal (Refer to GROUP 51, Rear Wiper and Washer P.51-21).

Post-installation Operation

- Adjustment of Clearance Around Liftgate (Refer to P.42-82).
- Alignment of Liftgate latch and Liftgate striker. (Refer to P.42-82).
- Adjustment of Liftgate Height (Refer to P.42-83).
- Rear Wiper Motor and Rear Washer Hose Installation (Refer to GROUP 51, Rear Wiper and Washer P.51-21).
- Liftgate Trim Assembly Installation (Refer to GROUP 52A, Liftgate Trim P.52A-36).

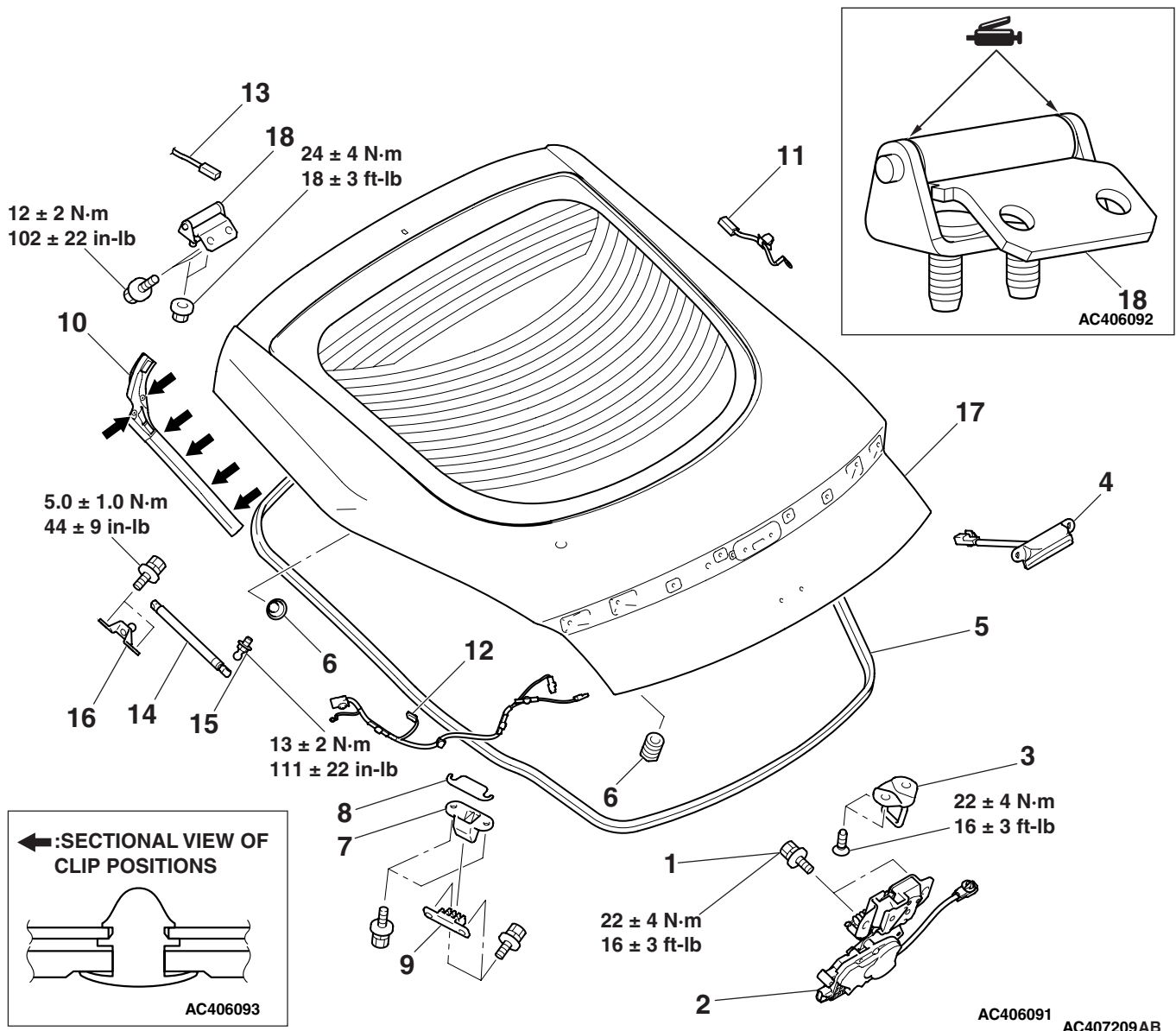

DOUBLE-SIDED TAPE POSITION

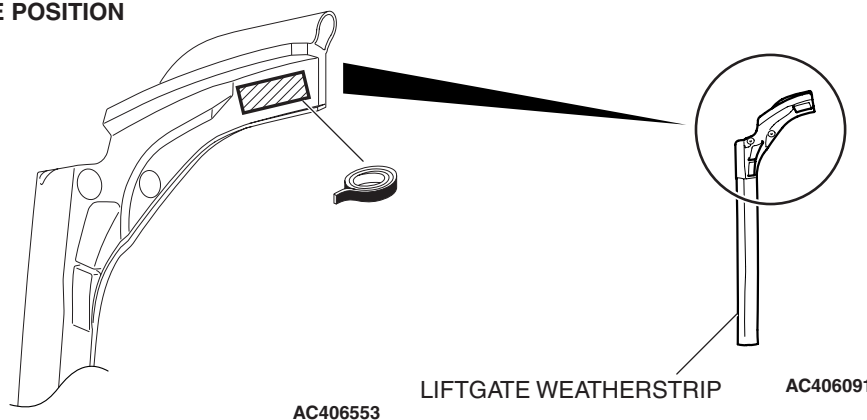

ADHESIVE TAPE: DOUBLE-SIDED TAPE [11 mm (0.43 in) WIDTH, 32 mm (1.26 in) LENGTH AND 1.1 mm (0.043 in) THICKNESS]

**LIFTGATE LATCH ASSEMBLY
REMOVAL STEPS**

- REAR END TRIM (REFER TO GROUP 52A, TRIMS P.52A-31.)
- 1. EARTH BOLT
- 2. LIFTGATE LATCH ASSEMBLY

STRIKER REMOVAL

- 3. STRIKER

**LIFTGATE LOCK RELEASE
HANDLE REMOVAL STEPS**

- HIGH-MOUNTED STOPLIGHT (REFER TO GROUP 54A, HIGH-MOUNTED STOPLIGHT P.54A-147.)
- 4. LIFTGATE LOCK RELEASE HANDLE

**LIFTGATE OPENING
WEATHERSTRIP REMOVAL**

- >>C<< 5. LIFTGATE OPENING WEATHERSTRIP

**LIFTGATE ASSEMBLY REMOVAL
STEPS**

- 6. LIFTGATE DAMPER
- 7. LIFTGATE UPPER DAMPER
- 8. LIFTGATE DAMPER STOPPER SHIM
- 9. LIFTGATE LOWER DAMPER
- REAR WASHER NOZZLE (REFER TO GROUP 51, REAR WIPER AND WASHER P.51-21.)
- 10. LIFTGATE WEATHERSTRIP
- RADIO AMPLIFIER AND FEEDER ANTENNA (REFER TO GROUP 54A, ANTENNA P.54A-230.)
- 11. REAR DEFOGGER HARNESS
- 12. LIFTGATE WIRING HARNESS
- 13. FLOOR WIRING HARNESS
- 14. LIFTGATE GAS SPRING
- 15. BALL JOINT
- 16. LIFTGATE GAS SPRING BRACKET
- 17. LIFTGATE ASSEMBLY
- HEADLINING (REFER TO GROUP 52A, HEADLINING P.52A-37.)
- >>A<< 18. LIFTGATE HINGE

<<A>> >>B<<

<>

REMOVAL SERVICE POINTS

<<A>> FLOOR WIRING HARNESS REMOVAL

1. Tie a cord at the tip of the floor wiring harness.
2. Remove the floor wiring harness from the liftgate by pulling in the arrowed direction in the illustration.

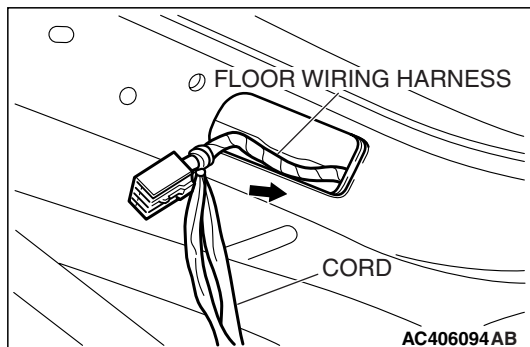

<> LIFTGATE GAS SPRING REMOVAL

Slide the pin and remove the liftgate gas spring toward the arrowed direction as shown. Then, remove the ball joint and the liftgate gas spring bracket.

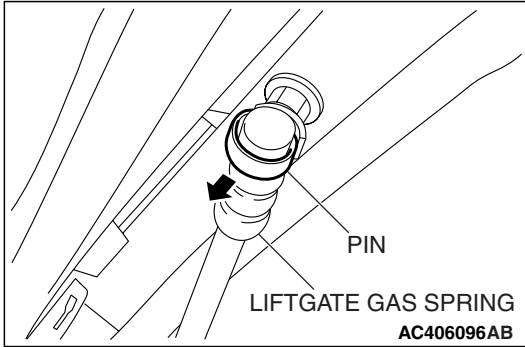
**INSTALLATION SERVICE POINTS****>>A<< LIFTGATE HINGE INSTALLATION**

Apply the specified sealing agent to the liftgate hinge assembly surface.

Specified Sealant: 3M™ AAD Part No. 8531 Heavy drip check sealer, 3M™ AAD Part No. 8646 Automotive joint and seam sealer or equivalent

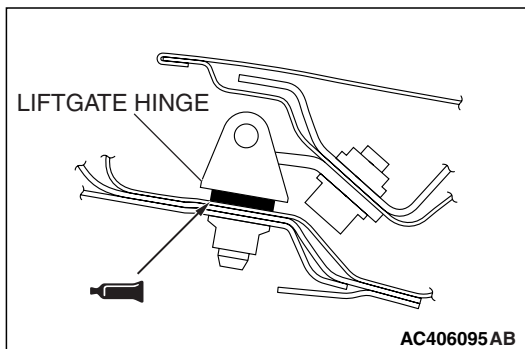
**>>B<< FLOOR WIRING HARNESS INSTALLATION**

Pull the cord and install the floor wiring harness to the liftgate.

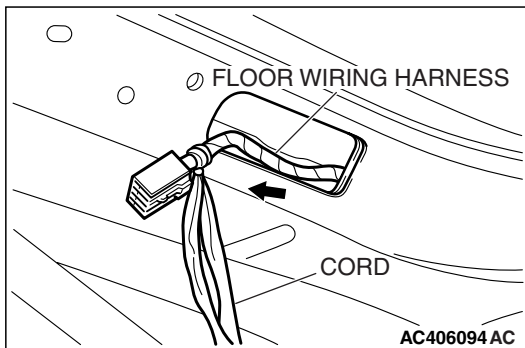
**>>C<< LIFTGATE OPENING WEATHERSTRIP INSTALLATION**

Assemble so the liftgate opening weatherstrip markings are at the center of the body and body panel joint.

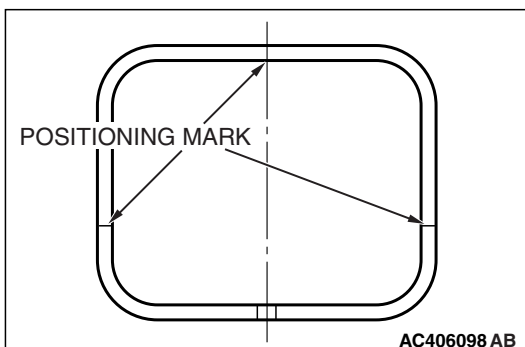

INSPECTION

M1424001200227

**LIFTGATE LOCK RELEASE HANDLE
CONTINUITY CHECK**

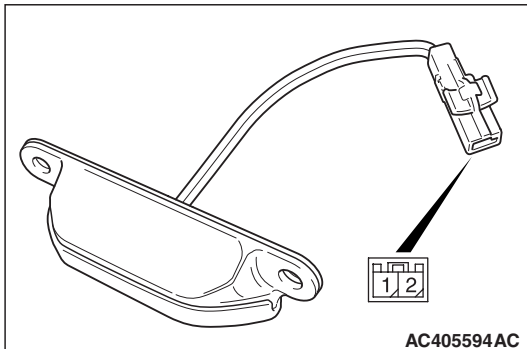

HANDLE POSITION	TESTER CONNECTION	SPECIFIED CONDITION
At the "ON (push)" position	1 - 2	Less than 2 ohms
At the "OFF" position	1 - 2	Open circuit

LIFTGATE LATCH CHECK

LIFTGATE LOCK ACTUATOR

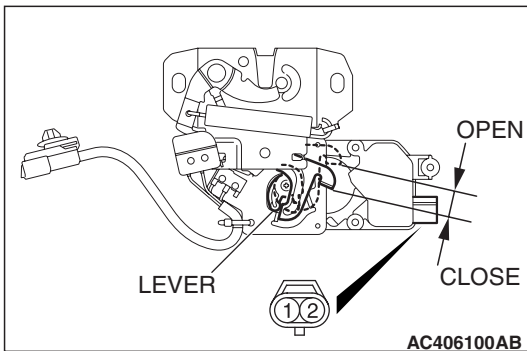

LEVER POSITION	BATTERY CONNECTION	LEVER OPERATION
At the "CLOSE" position	<ul style="list-style-type: none"> Connect terminal No. 1 and the negative battery terminal. Connect terminal No. 2 and the positive battery terminal. 	The lever moves from the "CLOSE" position to the "OPEN" position.

LIFTGATE SWITCH

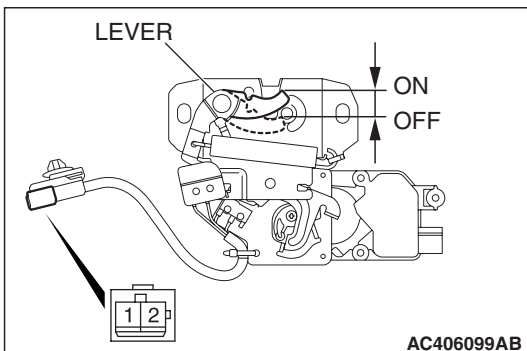

LEVER POSITION	TESTER CONNECTION	SPECIFIED CONDITION
At the "ON" position	1 - 2	Less than 2 ohms
At the "OFF" position	1 - 2	Open circuit

KEYLESS ENTRY SYSTEM

GENERAL DESCRIPTION

M1428000100359

- Antenna and receiver are incorporated in the ETACS-ECU.
- Encrypted code can be registered by using scan tool MB991958 (MUT-III sub assembly).
- The transmitter is integrated into the master key, and it consists of lock button, unlock button, lift-gate button and panic button.
- When the transmitter unlock button is pressed once, the driver's door will be unlocked. If the button is pressed twice, all the doors and liftgate will be unlocked.
- When the transmitter is operated, the answerback function will work as follows:

ITEM	OPERATION	
	DOORS AND LIFTGATE LOCKED	DOORS AND LIFTGATE UNLOCKED
Dome light	Flashes once	Illuminates for 15 seconds
Turn-signal lights (RH and LH)	Flashes once	Flashes twice
Horn	Sounds once when the lock button is pressed with all the doors and liftgate locked	-

- The answerback operation can be adjusted as follows:

ITEM	ADJUSTMENT ITEM	ADJUSTMENT DETAIL
Keyless entry system confirmation by turn signal lights	Adjustment of hazard answerback when the transmitter is used to lock doors	When adjusting hazard answerback after the doors are locked with the transmitter, the following flashing conditions can be selected. a. Flash (default) b. No flash
	Adjustment of hazard answerback when the transmitter is used to unlock doors	When adjusting hazard answerback after the doors are unlocked with the transmitter, the following flashing conditions can be selected. a. Flash (default) b. No flash
Keyless entry system confirmation by horn	Adjustment of horn answerback when the transmitter is used to lock doors	When adjusting horn answerback after the doors are locked with the transmitter, the following horn conditions can be selected. a. Horn sounds b. Horn sounds if doors are already locked (default) c. Horn does not sound

- If none of the doors are opened or the ignition key is not inserted in the ignition switch within 30 seconds after the doors are unlocked using the transmitter, the ETACS-ECU will relock the doors automatically.

NOTE: The timer lock period begins when the doors are unlocked, and ends when the doors are relocked automatically.







KEYLESS ENTRY SYSTEM DIAGNOSIS

M1428000700492

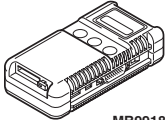
The keyless entry system is controlled by the Simplified Wiring System (SWS). Refer to GROUP 54B, Diagnosis [P.54B-57](#).

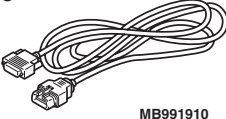
SPECIAL TOOL

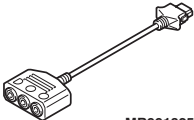
M1428000600622

TOOL	TOOL NUMBER AND NAME	SUPERSESION	APPLICATION
<p>A</p>  <p>MB991824</p> <p>B</p>  <p>MB991827</p> <p>C</p>  <p>MB991910</p> <p>D</p>  <p>MB991911</p> <p>E</p>  <p>MB991914</p> <p>F</p>  <p>MB991825</p> <p>G</p>  <p>MB991826 MB991958</p>	<p>MB991958</p> <p>A: MB991824 B: MB991827 C: MB991910 D: MB991911 E: MB991914 F: MB991825 G: MB991826</p> <p>MUT-III Sub Assembly</p> <p>A: Vehicle communication interface (V.C.I.) B: MUT-III USB cable C: MUT-III main harness A (Vehicles with CAN communication system) D: MUT-III main harness B (Vehicles without CAN communication system) E: MUT-III main harness C (for Daimler Chrysler models only) F: MUT-III measurement adapter G: MUT-III trigger harness</p>	<p>MB991824-KIT</p> <p><i>NOTE: G: MB991826 MUT-III Trigger Harness is not necessary when pushing V.C.I. ENTER key.</i></p>	<p>For registration of Encrypted code</p> <p>⚠ CAUTION</p> <p>For vehicles with CAN communication, use MUT-III main harness A to send simulated vehicle speed. If you connect MUT-III main harness B instead, the CAN communication does not function correctly.</p>

ON-VEHICLE SERVICE

KEYLESS ENTRY SYSTEM INSPECTION

M1428001400256

Check the following items. If defective, refer to GROUP 54B, Diagnosis P.54B-57.

1. Operate the transmitter to check that the doors and liftgate can be locked and unlocked.
 - When the unlock button is pressed once, the driver's door will be unlocked. Then when the button is pressed once again, all the doors and liftgate will be unlocked.
2. Press the liftgate button of transmitter twice (press once, and then press again within 5 seconds) and confirm that the liftgate opens.
3. Operate the transmitter to check that the answerback function works in response to doors and liftgate locking/unlocking.

NOTE: The adjustment function allows you to change the hazard answerback setting as follows. Prior to that check, confirm which setting is activated.

- a. *Turn-signal lights: Flash once when doors and liftgate are locked, and twice when unlocked (initial setting).*
- b. *Turn-signal lights: Flash once when doors and liftgate are locked, but does not flash when unlocked.*
- c. *Turn-signal lights: Do not flash when doors and liftgate are locked, but flash twice when unlocked.*
- d. *Turn-signal lights: Do not flash when doors and liftgate are locked and unlocked.*

NOTE: The adjustment function allows you to change the horn answerback setting as follows. Prior to that check, confirm which setting is activated.

- a. *Horn: Sounds once when the lock button is pressed.*
- b. *Horn: Sounds once when the lock button is pressed with the doors locked (initial setting).*
- c. *Horn: Does not sound.*

KEYLESS ENTRY SYSTEM TIMER LOCK FUNCTION INSPECTION

M1428004000309

If the doors are not locked within 30 seconds after the unlock button is pressed, refer to GROUP 54B, Diagnosis P.54B-57.

NOTE: If either of the doors is opened or the key is inserted in the ignition switch within that 30-seconds period, the timer lock function will be cancelled.

ENABLING/DISABLING THE ANSWERBACK FUNCTION

M1428003200474

When the doors are locked or unlocked by using the transmitter, the dome light will flash/illuminate, the turn-signal lights will flash (hazard answerback), or the horn will sound (horn answerback) to inform the driver.

The hazard answerback and horn answerback functions can be enabled or disabled according to the following procedure:

ENABLING/DISABLING THE HAZARD ANSWERBACK FUNCTION

HOW TO ADJUST HAZARD ANSWERBACK WHEN THE TRANSMITTER IS USED TO LOCK DOORS

1. Remove the ignition key.
2. Press the "unlock" button for 4 to 10 seconds and press the "lock" button during this time.
3. Release the "lock" button and then release the "unlock" button within 10 seconds of pressing the "lock" button in Step 2. The ETACS-ECU tone alarm will sound, indicating that the hazard answerback function can be enabled or disabled when the doors are locked.
 - **Enable the hazard answerback function when the doors are locked: The ETACS-ECU tone alarm will sound once.**
 - **Disable the hazard answerback function when the doors are locked: The ETACS-ECU tone alarm will sound twice.**

HOW TO ADJUST HAZARD ANSWERBACK WHEN THE TRANSMITTER IS USED TO UNLOCK DOORS

1. Remove the ignition key.
2. Press the "unlock" button for 4 to 10 seconds and press the "lock" button during this time.
3. Release the "unlock" button and then release the "lock" button within 10 seconds of pressing the "lock" button in Step 2. The ETACS-ECU tone alarm will sound, indicating that the hazard answerback function can be enabled or disabled when the door are unlocked.
 - **Enable the hazard answerback function when the doors are unlocked: The ETACS-ECU tone alarm will sound once.**
 - **Disable the hazard answerback function when the doors are unlocked: The ETACS-ECU tone alarm will sound twice.**

**ENABLING/DISABLING THE HORN
ANSWERBACK FUNCTION**

1. Remove the ignition key.
2. Press the "lock" button for 4 to 10 seconds and press the "unlock" button during this time.
3. Release the "lock" and "unlock" buttons within 10 seconds of pressing the "unlock" button in Step 2. The ETACS-ECU tone alarm will sound, indicating that the horn answerback function can be enabled or disabled.
 - **Enable the horn answerback function*:** The ETACS-ECU tone alarm will sound once.
 - **Disable the horn answerback function:** The ETACS-ECU tone alarm will sound twice.
 - **Enable the horn answerback function**:** The ETACS-ECU tone alarm will sound three times.

NOTE:

*: *The horn will sound if the doors are locked with the keyless entry system.*

**: *The horn will sound if the doors are already locked and the keyless entry lock button is operated.*

HOW TO REGISTER SECRET CODE

M1428001000708

CAUTION

- When adding the ignition key separately, or replacing the components by the steering lock cylinder of illustration <A> (the ignition key is simultaneously supplied) or the key set of illustration , register the encrypted code. Refer to GROUP 54A, Encrypted Code Registration Criteria Table P.54A-13.

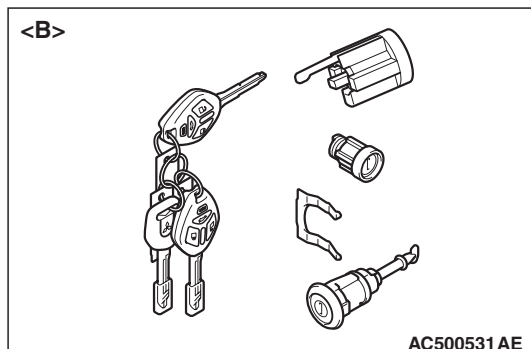
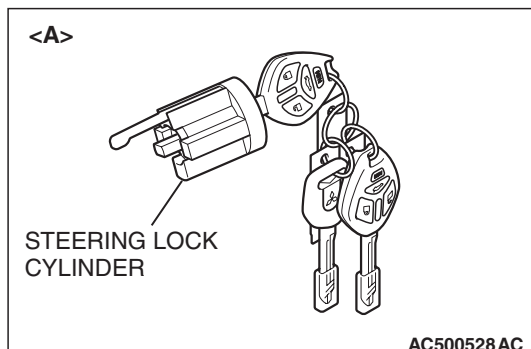
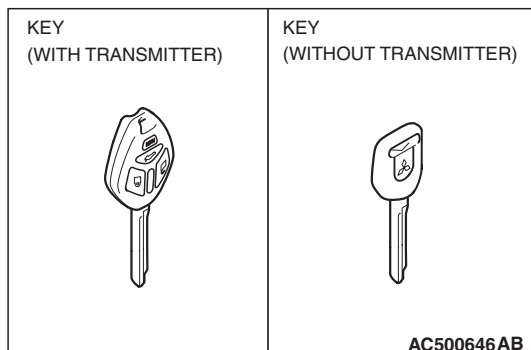

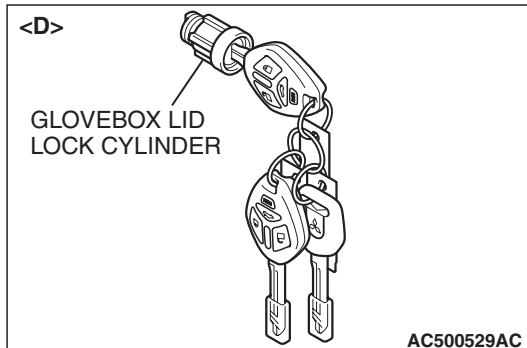
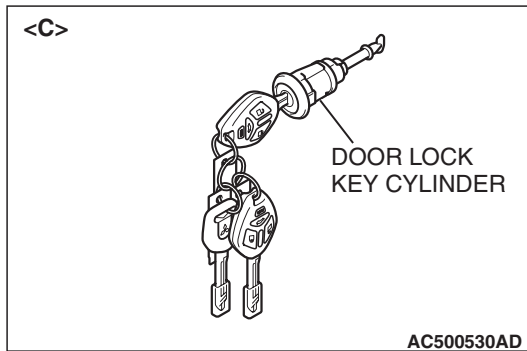

- When replacing the components by the door lock key cylinder of illustration <C> or the glove box lid lock cylinder of illustration <D>, do not register the encrypted code with the bar code on the ignition key which is supplied to each lock cylinder simultaneously.

Required Special Tools:

- MB991958: MUT-III Sub Assembly
 - MB991824: Vehicle Communication Interface (V.C.I.)
 - MB991910: MUT-III Main harness A

Each individual secret code is registered inside the transmitter, and so it is necessary to register these codes with the EEPROM inside the receiver in the following cases.

- When the transmitter or ETACS-ECU is replaced.
- If more transmitters are to be used.
- If it appears that a problem is occurring because of faulty registration of a code.

A maximum of four different codes can be stored in the EEPROM memory (four different transmitters can be used). When the code for the first transmitter is registered, the previously registered codes for all transmitters are cleared. Therefore, if you are using four transmitters or are adding more transmitters, the codes for all transmitters must be registered at the same time.

WHEN SPECIAL TOOL MB991824 (V.C.I.) IS USED

1. Check that the doors lock normally when the key is used.
2. Insert the ignition key.

⚠ CAUTION

To prevent damage to special tool MB991824 (V.C.I.), always turn the ignition switch to “LOCK” (OFF) position before connecting or disconnecting special tool MB991824 (V.C.I.).

3. Connect special tool MB991824 (V.C.I.) to the data link connector.

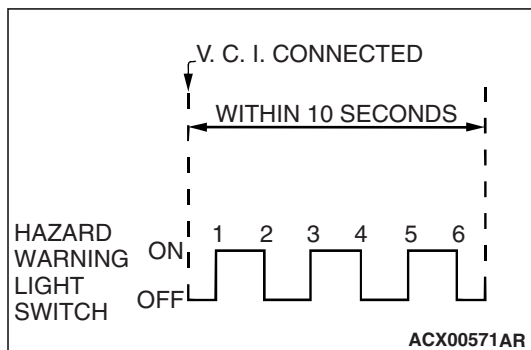
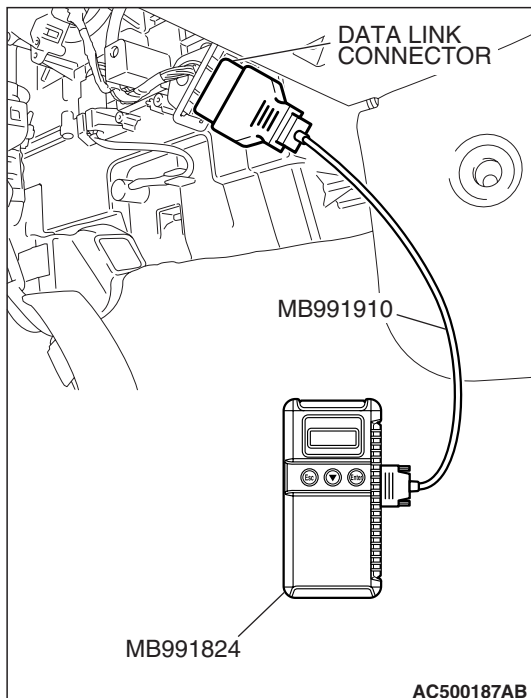

4. Press the hazard warning light switch six times within 10 seconds.

NOTE: When the hazard warning light switch has been pressed six times, the ETACS-ECU locks and unlocks the doors automatically once. The ETACS-ECU is ready to register an encrypted code.

NOTE: The hazard warning light switch is a toggle switch.
5. Press the transmitter button, and then press it two times within 10 seconds of the first press. This will register the code.
6. When the encrypted code has been registered, the ETACS-ECU locks and unlocks the doors automatically once.
7. If you are using two or more transmitters or have added a second transmitter, the next transmitter should be registered within one minute after registering the code for the previous transmitter. The registration procedure is common for all the transmitter.
8. Registration mode will be canceled under the following conditions:
 - When the secret code for four transmitters has been registered;
 - When passing one minute after finishing the registration of all transmitters;
 - When special tool MB991824 (V.C.I.) is disconnected;
 - When the key is removed from the key cylinder;

9. After the registration is completed, remove the ignition key and close all the doors, and then check that the keyless entry system operates normally.

TRANSMITTER

DISASSEMBLY AND ASSEMBLY

M1428002800279

Post-installation operation

- Transmitter operation check

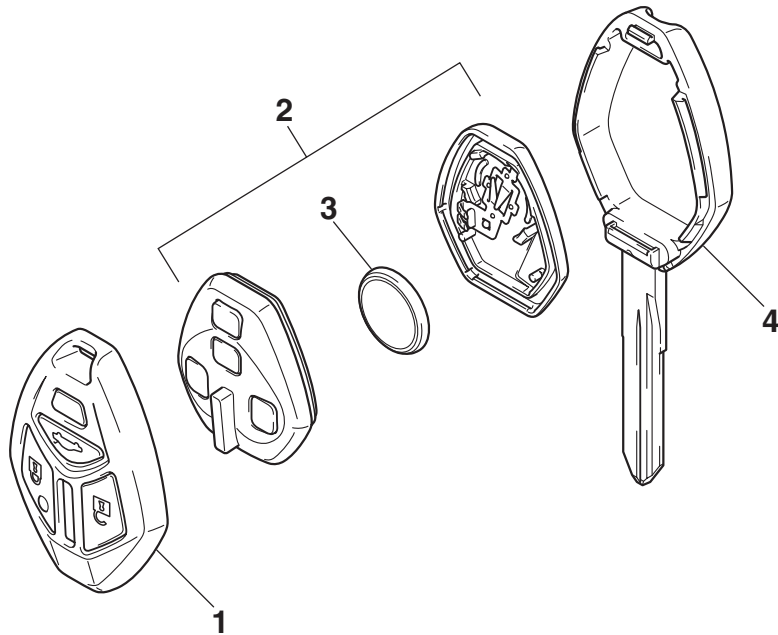

AC405679AB

<<A>>

DISASSEMBLY STEPS

1. UPPER COVER
2. TRANSMITTER ASSEMBLY

<>

>>A<<

DISASSEMBLY STEPS

3. BATTERY
4. MASTER KEY

DISASSEMBLY SERVICE POINTS

<<A>> UPPER COVER REMOVAL

CAUTION

To prevent damage to the transmitter, wrap a flat-tipped screwdriver with protective tape before prying. Insert a flat-tipped screwdriver in the area shown, and remove the upper cover by prying it with the screwdriver.

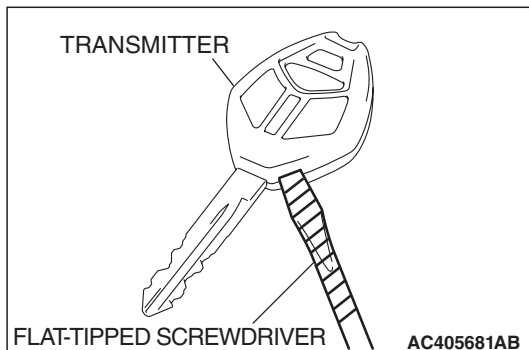

<> BATTERY REMOVAL

⚠ CAUTION

- Do not allow water or dust to enter the inside of the transmitter assembly when it is open. Also, do not touch the precision electronic device.
- To prevent damage to the transmitter assembly, wrap a flat-tipped screwdriver with protective tape before prying.

Insert a flat-tipped screwdriver in the area shown, and remove the battery by prying it with the screwdriver.

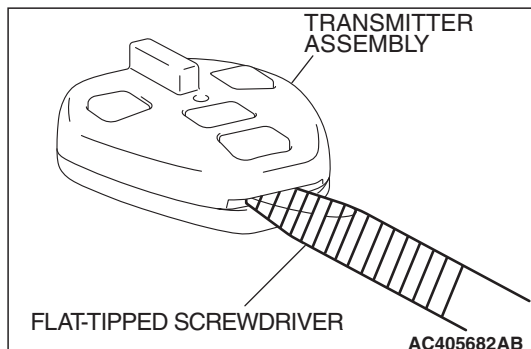

ASSEMBLY SERVICE POINT

>>A<< BATTERY INSTALLATION

⚠ CAUTION

Do not allow water or dust to enter the inside of the transmitter assembly when it is open. Also, do not touch the precision electronic device.

Install a new battery to the transmitter assembly with its (+) side facing towards the master key side.

Battery required for replacement: Coin type battery CR1620

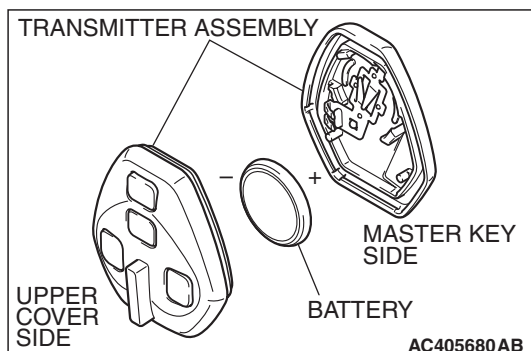

INSPECTION

M1428003800186

TRANSMITTER BATTERY CHECK

Measure the voltage of the battery. If the voltage of the battery is not within the standard value, replace the battery.

Standard value: 2.5 – 3.2 V

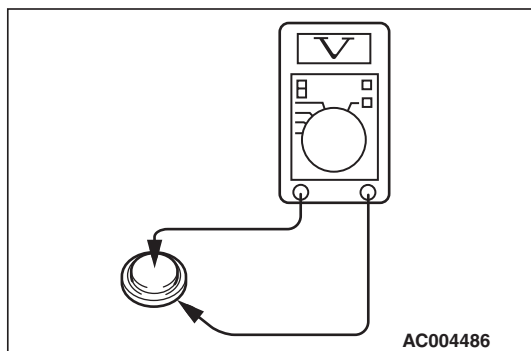

SUNROOF ASSEMBLY**GENERAL DESCRIPTION**

M1426000100267

A motor-driven inner slide-type glass sunroof with a tilt-up mechanism is available in some models as a standard or optional equipment. Even when the sunroof is fully closed, a sufficient amount of lighting and a feeling of openness can still be obtained by opening the sunroof sunshade.



SUNROOF DIAGNOSIS

M1426000700418

The sunroof system is controlled by the Simplified Wiring System (SWS). Refer to GROUP 54B, Diagnosis P.54B-57.

SPECIAL TOOLS

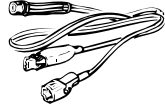
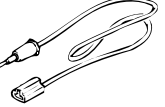
M1426000600295

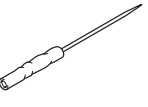
TOOL	TOOL NUMBER AND NAME	SUPERSESSION	APPLICATION
<p>A</p>  <p>B</p>  <p>C</p>  <p>D</p>  MB991223AZ	MB991223 Harness set A: MB991219 Test harness B: MB991220 LED harness C: MB991221 LED harness adapter D: MB991222 Probe	General service tools	Measurement of terminal voltage and resistance A: Connector pin contact pressure inspection B: Power circuit inspection C: Power circuit inspection D: Commercial tester connection
 MB992006	MB992006 Extra fine probe	–	Measurement of terminal voltage and resistance

ON-VEHICLE SERVICE**WATER TEST**

M1426000900393

Check if there are any leaks in the sunroof by the following procedure.

1. Fully close the roof lid glass.
2. Adjust the water pressure so that water comes out of the hose to a height of approximately 50 cm (19.7 inches) when the hose is held vertically facing upwards.

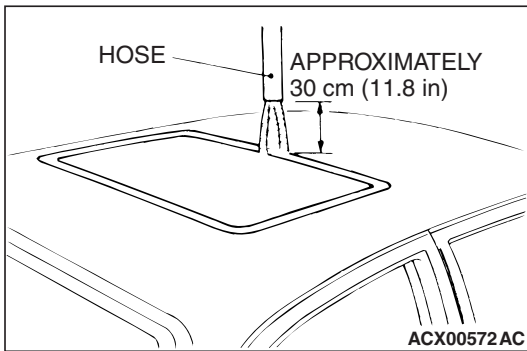

3. Hold the end of the hose approximately 30 cm (11.8 inches) above the roof and let the water run onto the weatherstrip for 5 minutes or more.
4. Check if any water leaks can be found in the room while watering. Even though there are any water leaks around the roof lid glass, it can be acceptable as long as water is caught in the drip area.

SUNROOF FIT ADJUSTMENT

M1426001000401

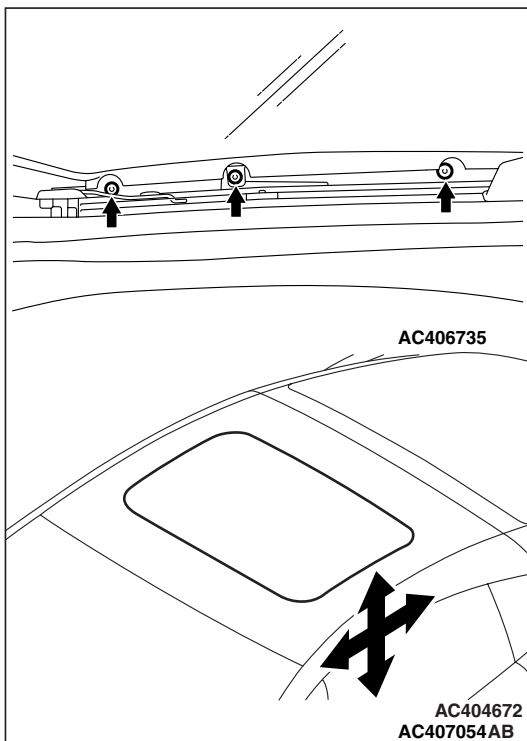

1. Fully close the roof lid glass.
2. Fully open the sunshade.
3. Loosen the roof lid glass assembly mounting screws. Align the roof lid glass by moving it backward, forward, up or down along the guide oblong hole so that the clearance between the glass and the vehicle body is even.
4. Check to be sure that the roof lid glass is flush with the roof panel at corner areas.
5. Check to be sure that the sunroof operates smoothly.

SUNROOF CHECK

M1426004700261

Check to see that the sunroof operates by pressing the sunroof switch. Perform troubleshooting if operations malfunction (Refer to GROUP 54B, Diagnosis [P.54B-57](#)).

SUNROOF TIMER FUNCTION CHECK

M1426004300155

Keep the door closed, turn OFF the ignition switch and check to see if the sunroof can be operated for 30 seconds after that. If not, perform troubleshooting (Refer to GROUP 54B, Diagnosis [P.54B-57](#)).

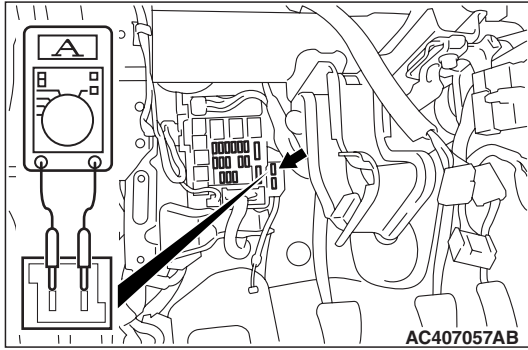

ROOF LID GLASS OPERATION CURRENT CHECK

M1426003200285

1. Remove the fuse of the sunroof, then connect the circuit tester as shown in the Figure.
2. Turn ON the sunroof switch, then measure the operating current when the roof lid glass is halfway opened.
Standard value: 7 A or less [at 20 ° C (68 ° F)]
3. Check the following areas if the operating current exceeds the standard value:
 - Sunroof installation, deformation and presence of any foreign substances.
 - Drive cable installation.
 - Tilting of roof lid glass.

SUNROOF OPERATION CHECK

M1426002600440

⚠ CAUTION

Check that the following items are normal before carrying out this operation check.

- Installation condition of the sunroof assembly
- Installation condition, deformation and contamination of the sunroof drive cable
- Installation of sunroof lid glass
- Sunroof switch and sunroof motor assembly

Check that the following items. If faulty, replace the sunroof motor assembly.

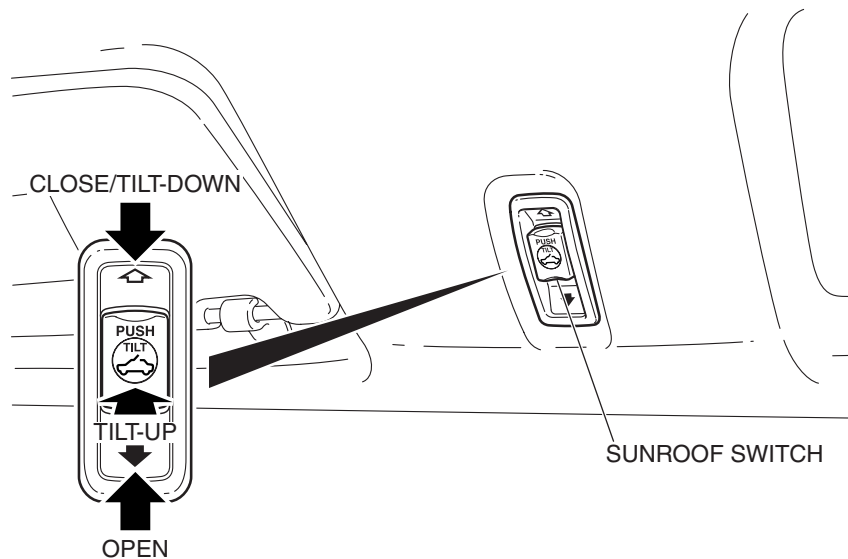

AC404868AB

BASIC OPERATION

NO.	SUNROOF FUNCTION	REQUIREMENTS FOR THE SUNROOF TO FUNCTION		NORMAL OPERATION
01	OPEN	1. Ignition switch: ON 2. Sunroof switch: OPEN		Automatically the sunroof fully opens.
02	CLOSE	1. Ignition switch: ON 2. Sunroof switch: CLOSE/TILT-DOWN		The sunroof closes while the sunroof switch is pushed to the CLOSE/TILT-DOWN position.
03	TILT-UP	1. Ignition switch: ON 2. Sunroof switch: TILT-UP		The sunroof tilts up fully and automatically.
04	TILT-DOWN	1. Ignition switch: ON 2. Sunroof switch: CLOSE/TILT-DOWN		The sunroof closes while the sunroof switch is pushed to the CLOSE/TILT-DOWN position.
05	AUTOMATIC OPERATION INTERRUPTION (OPEN)	A	1. Ignition switch: ON 2. Sunroof switch: OPEN or TILT-UP	The sunroof stops the automatic opening operation.
		B	1. Ignition switch: ON 2. Sunroof switch: CLOSE/TILT-DOWN (Push the sunroof switch to the CLOSE/TILT-DOWN position while the sunroof is automatically opening and release the switch within two seconds)	The sunroof stops the automatic opening operation.
		C	1. Ignition switch: ON 2. Sunroof switch: CLOSE/TILT-DOWN (Push the sunroof switch to the CLOSE/TILT-DOWN position more than two seconds while the sunroof is automatically opening)	The sunroof stops the automatic opening operation, and the sunroof closes while the sunroof switch is pushed to the CLOSE/TILT-DOWN position.
06	AUTOMATIC OPERATION INTERRUPTION (TILT-UP)	1. Ignition switch: ON 2. Sunroof switch: OPEN or TILT-UP, CLOSE/TILT-DOWN		The sunroof stops the automatic opening operation.

SUNROOF TIMER MECHANISM

In cases except the following, the basic operation and jam preventing mechanism will be maintained for thirty seconds after the ignition switch is turned to the "LOCK" (OFF) position. (Sunroof timer function)

- If you open a door within that period (i.e. a door switch is on), the sunroof timer function will be cancelled immediately.
- If you turn the ignition switch to the "LOCK" (OFF) position while the timer is working, the sunroof will continue moving until it closes fully, regardless of the time-out period.

SUNROOF ASSEMBLY
REMOVAL AND INSTALLATION

M1426001200524

Post-installation Operation <Roof lid glass assembly, Sunroof assembly>

- Sunroof Water Test (Refer to P.42-98).
- Sunroof Fit Adjustment (Refer to P.42-99).

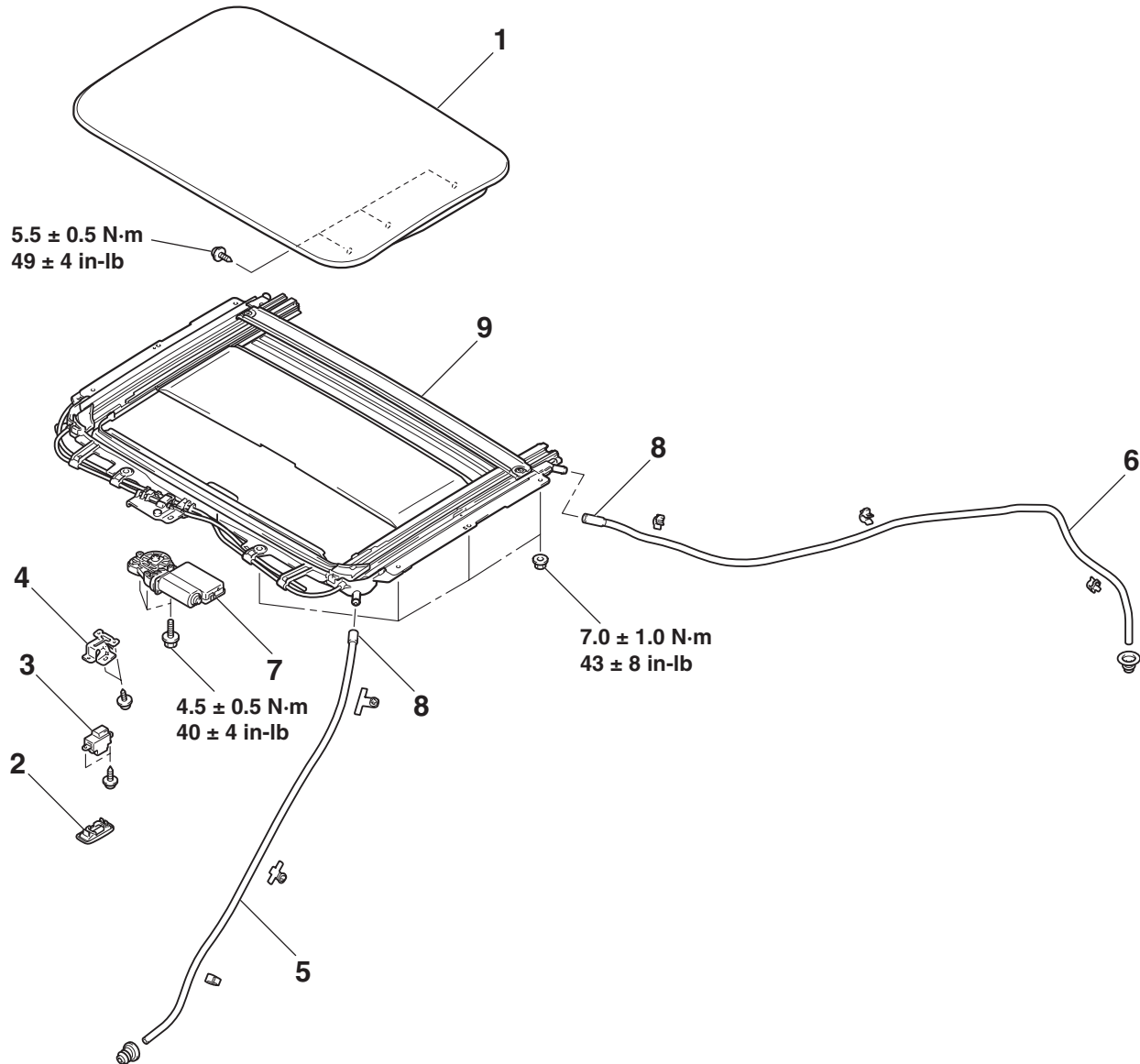

AC406731AB

ROOF WINDOW GLASS ASSEMBLY REMOVAL

1. ROOF LID GLASS ASSEMBLY

SUNROOF SWITCH REMOVAL STEPS

2. SUNROOF SWITCH COVER
3. SUNROOF SWITCH
 - HEADLINING ASSEMBLY (REFER TO GROUP 52A, HEADLINING P.52A-37.)
4. SUNROOF SWITCH BRACKET

FRONT DRAIN PIPE REMOVAL STEPS

2. SUNROOF SWITCH COVER
 - HEADLINING ASSEMBLY (REFER TO GROUP 52A, HEADLINING P.52A-37.)
 - ETACS-ECU (FRONT DRAIN PIPE <LH>) (REFER TO GROUP 54A, IMMOBILIZER SYSTEM P.54A-51.)

**FRONT DRAIN PIPE REMOVAL
STEPS (Continued)**

- FRONT SPLASH SHIELD FRONT DRAIN PIPE <RH> (REFER TO P.42-10.)

>>A<< 5. FRONT DRAIN PIPE

**REAR DRAIN PIPE REMOVAL
STEPS**

2. SUNROOF SWITCH COVER
- HEADLINING ASSEMBLY (REFER TO GROUP 52A, HEADLINING P.52A-37.)
- QUARTER WINDOW FLANGE TRIM (REFER TO GROUP 52A, TRIMS P.52A-31.)
- REAR SPLASH SHIELD (REFER TO GROUP 51, REAR BUMPER P.51-4.)

>>A<< 6. REAR DRAIN PIPE

**SUNROOF MOTOR ASSEMBLY
REMOVAL STEPS**

2. SUNROOF SWITCH COVER
- HEADLINING ASSEMBLY (REFER TO GROUP 52A, HEADLINING P.52A-37.)
7. SUNROOF MOTOR ASSEMBLY

**SUNROOF ASSEMBLY REMOVAL
STEPS**

1. ROOF LID GLASS ASSEMBLY
2. SUNROOF SWITCH COVER
- HEADLINING ASSEMBLY (REFER TO GROUP 52A, HEADLINING P.52A-37.)
7. SUNROOF MOTOR ASSEMBLY
8. FRONT AND REAR DRAIN PIPE CONNECTION
9. SUNROOF ASSEMBLY

Required Special Tool:

- MB991223: Harness set

INSTALLATION SERVICE POINT

**>>A<< REAR DRAIN PIPE/FRONT DRAIN PIPE
INSTALLATION**

Install the grommet, and then position the drain pipe so that it protrudes from the grommet as shown in the illustration.

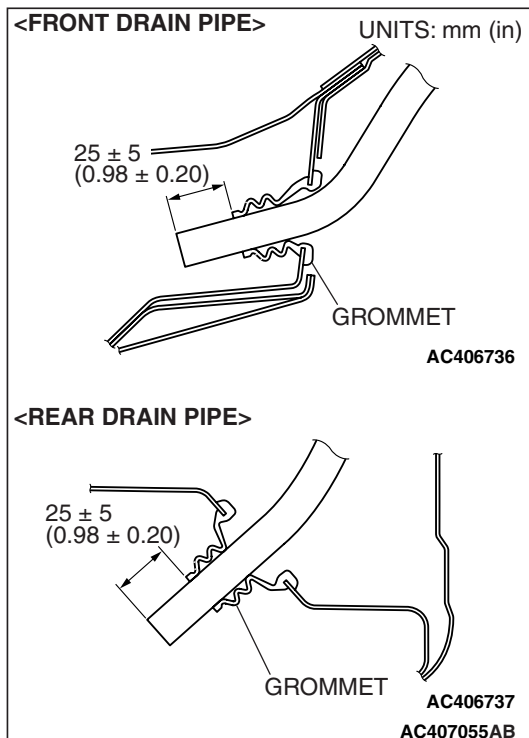

INSPECTION

M1421007600718

SUNROOF SWITCH CONTINUITY CHECK

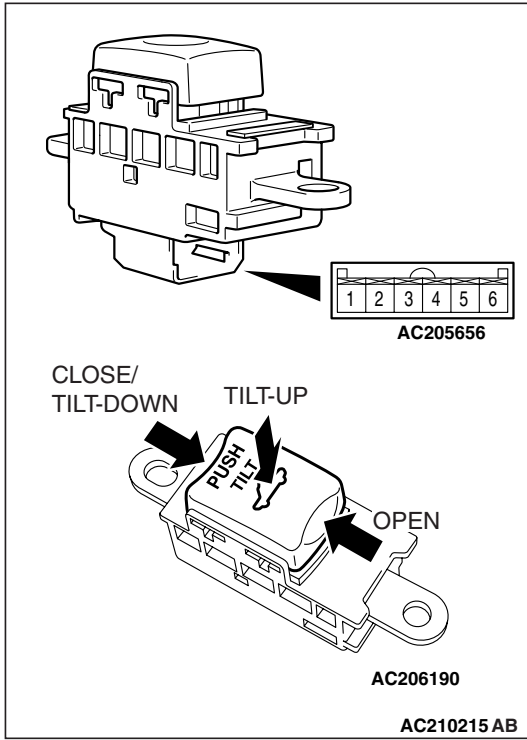

SWITCH POSITION	TESTER CONNECTION	SPECIFIED CONDITION
Open	4 – 5	Less than 2 ohms
Off	3 – 4, 3 – 5, 3 – 6, 4 – 5, 4 – 6, 5 – 6	Open circuit
Tilt-up	3 – 4	Less than 2 ohms
Close/Tilt-down	4 – 6	Less than 2 ohms

DISASSEMBLY AND ASSEMBLY

M1426001400368

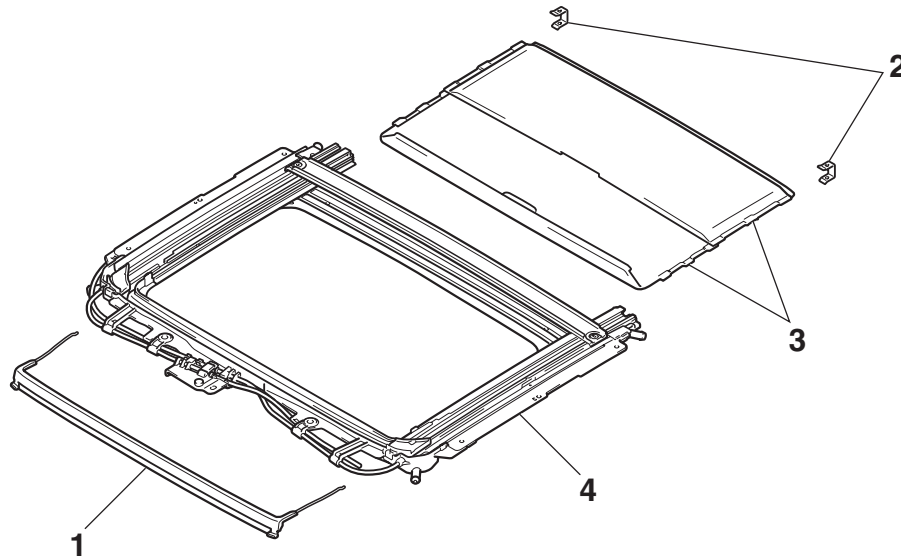

AC406748AB

DISASSEMBLY STEPS

1. SUNROOF DEFLECTOR
2. SUNROOF SUNSHADE STOPPER

DISASSEMBLY STEPS

3. SUNROOF SUNSHADE
4. SUNROOF HOUSING

LOOSE PANEL

REMOVAL AND INSTALLATION

M1421003100175

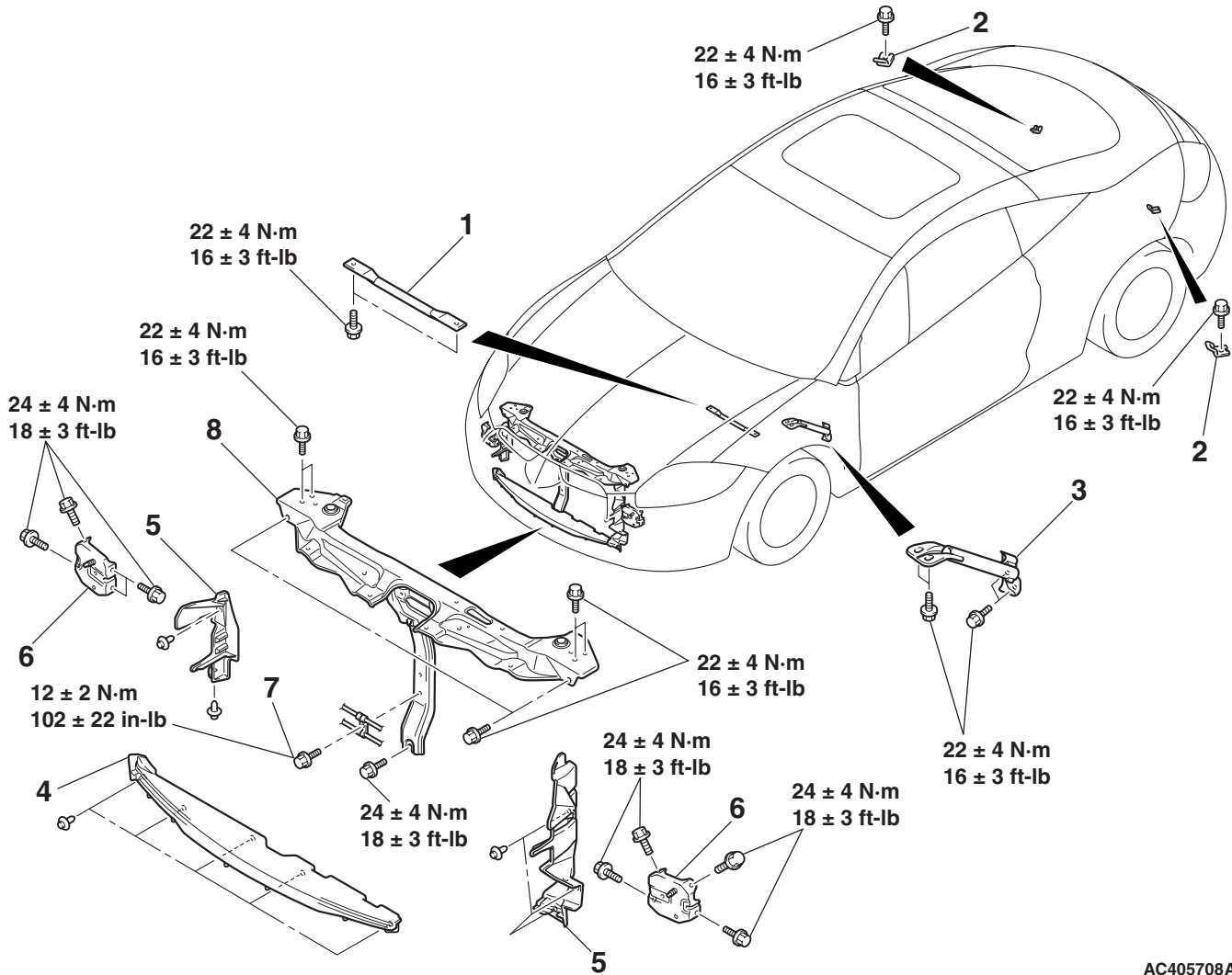

AC405708AB

REMOVAL

1. FRONT FLOOR BACKBONE BRACE
 2. CHILD RESTRAINT BRACKET
- UPPER FRAME TO FRONT PILLAR BRACE REMOVAL STEPS**
- SPLASH SHIELD (REFER TO P.42-10.)
3. UPPER FRAME TO FRONT PILLAR BRACE
- AIR GUIDE PANEL REMOVAL STEPS**
- FRONT BUMPER ASSEMBLY (REFER TO GROUP 51, FRONT BUMPER AND RADIATOR GRILLE P.51-2.)
4. AIR GUIDE PANEL CENTER

AIR GUIDE PANEL REMOVAL STEPS (Continued)

- FRONT BUMPER REINFORCEMENT ASSEMBLY (REFER TO GROUP 51, FRONT BUMPER AND RADIATOR GRILLE P.51-2.)
5. AIR GUIDE PANEL SIDE
- FRONT BUMPER REINFORCEMENT BRACKET REMOVAL STEPS**
- FRONT BUMPER REINFORCEMENT ASSEMBLY (REFER TO GROUP 51, FRONT BUMPER AND RADIATOR GRILLE P.51-2.)
5. AIR GUIDE PANEL SIDE
 6. FRONT BUMPER REINFORCEMENT BRACKET

FRONT END STRUCTURE BAR**REMOVAL STEPS**

- FRONT BUMPER ASSEMBLY
(REFER TO GROUP 51, FRONT
BUMPER AND RADIATOR GRILLE
[P.51-2.](#))
- HOOD DAMPER AND HOOD LATCH
(REFER TO [P.42-7.](#))
- 7. COOLER TUBE ASSEMBLY
MOUNTING BOLT
- 8. FRONT END STRUCTURE BAR

SPECIFICATIONS

FASTENER TIGHTENING SPECIFICATIONS

M1421005300272

ITEM	SPECIFICATION
Hood	
Hood hinge bolt (body side)	12 ± 2 N· m (102 ± 22 in-lb)
Hood hinge bolt (hood side)	12 ± 2 N· m (102 ± 22 in-lb)
Hood hinge nut (body side)	12 ± 2 N· m (102 ± 22 in-lb)
Hood latch bolt	9.0 ± 2.0 N· m (80 ± 17 in-lb)
Fuel filler lid	
Fuel filler neck reinforcement plate bolt	5.0 ± 1.0 N· m (44 ± 9 in-lb)
Strut tower bar	
Strut tower bar bolt	12 ± 2 N· m (102 ± 22 in-lb)
Strut tower bar nut	12 ± 2 N· m (102 ± 22 in-lb)
Door	
Door check bolt (body side)	9.0 ± 2.0 N· m (80 ± 17 in-lb)
Door check bolt (door side)	5.0 ± 1.0 N· m (44 ± 9 in-lb)
Door hinge bolt (body side)	27 ± 5 N· m (20 ± 4 ft-lb)
Door hinge bolt (door side)	21 ± 4 N· m (16 ± 2 ft-lb)
Door latch assembly screw	5.9 ± 1.0 N· m (52 ± 9 in-lb)
Door outside handle bolt	9.0 ± 2.0 N· m (80 ± 17 in-lb)
Door switch screw	3.9 ± 1.0 N· m (35 ± 8 in-lb)
Door window module assembly bolt	9.0 ± 2.0 N· m (80 ± 17 in-lb)
Delta window glass bolt	10 ± 1 N· m (89 ± 8 in-lb)
	27 ± 1 N· m (20 ± 1 ft-lb)
Delta window glass nut	10 ± 1 N· m (89 ± 8 in-lb)
Striker screw	24 ± 3 N· m (18 ± 2 ft-lb)
Liftgate	
Ball joint	13 ± 2 N· m (111 ± 22 in-lb)
Liftgate gas spring bracket bolt	5.0 ± 1.0 N· m (44 ± 9 in-lb)
Liftgate hinge bolt (liftgate side)	12 ± 2 N· m (102 ± 22 in-lb)
Liftgate hinge nut (body side)	24 ± 4 N· m (18 ± 3 ft-lb)
Liftgate latch bolt	22 ± 4 N· m (16 ± 3 ft-lb)
Striker screw	22 ± 4 N· m (16 ± 3 ft-lb)
Sunroof	
Roof lid glass screw	5.5 ± 0.5 N· m (49 ± 4 in-lb)
Sunroof assembly nut	7.0 ± 1.0 N· m (43 ± 8 in-lb)
Sunroof motor bolt	4.5 ± 0.5 N· m (40 ± 4 in-lb)
Loose panel	
Child restraint bracket bolt	22 ± 4 N· m (16 ± 3 ft-lb)
Cooler tube assembly bolt	12 ± 2 N· m (102 ± 22 in-lb)

ITEM	SPECIFICATION
Front bumper reinforcement bracket bolt	24 ± 4 N· m (18 ± 3 ft-lb)
Front end structure bar bolt	22 ± 4 N· m (16 ± 3 ft-lb)
	24 ± 4 N· m (18 ± 3 ft-lb)
Front floor backbone brace bolt	22 ± 4 N· m (16 ± 3 ft-lb)
Upper frame to front pillar brace bolt	22 ± 4 N· m (16 ± 3 ft-lb)

SERVICE SPECIFICATIONS

M1421000300482

<DOOR>

ITEM	STANDARD VALUE
Door inside handle knob play mm (in)	73.6 (2.90)
Door inside handle lock knob stroke mm (in)	14.9 ± 0.5 (0.59 ± 0.020)
Door outside handle play mm (in)	63.5 (2.5)
Power window operation current A	5 ± 1 [Power supply voltage 14.5 ± 0.5V, 25° C (77° F)]

<KEYLESS ENTRY SYSTEM>

ITEM	STANDARD VALUE
Transmitter battery V	2.5 – 3.2

<SUNROOF>

ITEM	STANDARD VALUE
Roof lid glass operation current A	7 or less [at 20° C(68° F)]

SEALANT AND ADHESIVES

M1421000500248

<WINDOW GLASS>

ITEM	SPECIFIED ADHESIVE
Liftgate window glass	3 M™ AAD part No. 8609 super fast urethane and 3 M™ AAD part No. 8608 super fast urethane primer or equivalent
Quarter window glass	
Windshield	

<LIFTGATE>

ITEM	SPECIFIED SEALANT	REMARK
Liftgate hinge	3M™ AAD Part No. 8531 Heavy drip check sealer, 3M™ AAD Part No. 8646 Automotive joint and seam sealer or equivalent	Body sealer

ITEM	SPECIFIED ADHESIVE TAPE
Liftgate weatherstrip	Adhesive tape: Double-sided tape [11 mm (0.43 in) width, 32 mm (1.26 in) length and 1.1 mm (0.043 in) thickness]

COMPONENT IDENTIFICATIONS

M1421005400291

<DOOR CHECK>

APPLICABLE LOCATION	IDENTIFICATION MARK
LH	P2FL
RH	P2FR